

Playone Déco 87



FIR BATHROOM A&D

Playone Déco 87



Gli articoli della collezione Playone Déco sono disponibili nelle finiture sotto indicate:
The articles included in Playone Déco collection are available in the following finishings:
Die Artikel der Kollektion Playone Déco sind in folgenden Farben lieferbar:
Les articles de la collection Playone Déco sont disponibles dans les exécutions suivantes:
Los artículos de la colección Playone Déco están disponibles en los acabados abajo indicados:
Артикулы коллекции Playone Déco имеются в указанных ниже цветах:
在Playone Déco系列里的产品备有下列的颜色:

Chrome

Cromato / Chrome / Chrom / Chromé / Cromo / Хромированный / 镀铬

White Mood

Gold Glam glamour®

Black Coffee glamour®
(PVD)

Gold Colour glamour®
(PVD)

DATI TECNICI
TECHNICAL DATA
TECHNISCHE DATEN
DONNEES TECHNIQUES
DATOS TÉCNICOS
ТЕХНИЧЕСКИЕ ДАННЫЕ
技术数据

65° (max 80° C)

Temperatura ottimale acqua calda
Optimal hot water temperature
Optimaltemperatur vom warmen Wasser
Température optimale eau chaude
Temperatura óptima del agua caliente
Оптимальная температура горячей воды
最佳的热水温度

2 bar (min 1 - max 5)

Pressione ottimale di esercizio
Optimal operational pressure
Optimaler Betriebsdruck
Pression optimale de fonctionnement
Presión óptima de funcionamiento
Оптимальное рабочее давление
最佳工作压力

0,1 bar (max 1)

Differenza di pressione acqua calda/fredda
Hot/cold water pressure difference
Drucksunterschied vom warmen/kalten Wasser
Différence de pression eau chaude/froide
Diferencia de presión del agua caliente/fría
Разница давления холодной/горячей воды
冷/热水压力差

AVVERTENZE - REMARKS - ANMERKUNGEN - NOTES - NOTA - ПРЕДУПРЕЖДЕНИЯ - 警告

- Per i miscelatori monocomando FIR ITALIA consiglia l'installazione sulle due mandate di rubinetti filtro ispezionabili (Art. 11.0503.2, 11.0505.2), per trattenere eventuali corpi estranei che potrebbero danneggiare gli organi di tenuta della cartuccia. Nelle finiture con base White Mood, Gold Glam, Black Coffee, Gold Colour i flessibili sono in ottone con doppia aggraffatura e non in PVC.
- For the single lever mixers FIR ITALIA recommends the assembling of removable filter elbow connections (Art. 11.0503.2, 11.0505.2) in order to avoid possible obstructions or damages to the cartridge caused by deposit conveyed by water. For finishings on a White Mood, Gold Glam, Black Coffee, Gold Colour base, hoses are made of brass with double seam and not in PVC.
- Für die Einhebelmischer empfiehlt FIR ITALIA die Montage von Eckregulierventilen (Art. 11.0503.2, 11.0505.2), um eventuelle Fremdkörper aufzuhalten, welche die Kartusche beschädigen können. Bei der White Mood, Gold Glam, Black Coffee, Gold Colour-Ausführungen sind die Brauseschläuche aus Messing mit Doppelnaht und PVC-frei.
- Pour les mitigeurs FIR ITALIA conseille le montage de robinets filtre (Art. 11.0503.2, 11.0505.2), afin de retenir éventuels corps étrangers qui peuvent endommager les cartouches. Pour les finitions avec base White Mood, Gold Glam, Black Coffee, Gold Colour, les flexibles sont en laiton avec double agraffe et pas en PVC.
- FIR ITALIA aconseja instalar los mezcladores monomando en los dos lados de descarga de los grifos filtro inspeccionable (Art. 11.0503.2, 11.0505.2) para retener los posibles cuerpos extraños que puedan dañar los órganos de estanqueidad del cartucho. Para los acabados con base White Mood, Gold Glam, Black Coffee, Gold Colour, los flexibles son de latón con doble engrapado y no PVC.
- Для одноручковых смесителей FIR ITALIA рекомендует на двух подающих трубах кранов устанавливать проверяемые фильтры (Арт. 11.0503.2, 11.0505.2), для задержания возможных посторонних тел, которые могли бы повредить детали, обеспечивающие герметичность картриджа. На отделке на базе White Mood, Gold Glam, Black Coffee, Gold Colour шланги выполнены из латуни с двойным замковым соединением и не из ПВХ.
- 对于单把龙头 FIR ITALIA建议装配可卸式滤器的弯接头 (型号11.0503.2, 11.0505.2), 以避免可能出现的障碍物或供水中的沉淀物对阀芯造成损害。对于 White Mood, Gold Glam, Black Coffee, Gold Colour 基材的表面处理, 软管为双重接缝的黄铜并且不是PVC的。

FIR ITALIA si riserva, ogni qualvolta si rendesse necessario, di apportare modifiche tecniche ed estetiche senza obbligo di preavviso. - FIR ITALIA, whenever necessary, reserves itself the right of deciding technical and aesthetical modifications without prior notice. - FIR ITALIA ist ausdrücklich dazu berechtigt, technische und ästhetische Änderungen an ihre einigen Produkte ohne vorherige Mitteilung vorzunehmen. - FIR ITALIA se réserve le droit d'apporter des modifications techniques et esthétiques sans avis préalable. - FIR ITALIA se reserva el derecho, si lo considera necesario, de aportar modificaciones técnicas sin obligación de previo aviso. - FIR ITALIA оставляет за собой право во всех случаях, когда это будет необходимо, вносить технические и эстетические изменения без обязательства производить предварительное уведомление. - FIR ITALIA, 在必要时, 保留技术和外观修改的决定权, 恕不另行通知。

MADE IN ITALY

| | | |
|--|--|----------|
| Area lavabo Wash basin area • Waschtisch-Bereich • Zone du lavabo • Área lavabo • Зона умывальника • 面盆区域 | | page 249 |
| Area bidet/WC Bidet/WC area • Bidet/WC-Bereich • Zone du bidet/WC • Área bidé/WC • Зона биде/унитаз • 净身盆/厕所区域 | | page 254 |
| Area vasca/doccia Bath/shower area • Badewannen-Duschbereich • Zone de la baignoire/de douche • Área bañera/ducha • Зона ванны/душа • 浴缸/淋浴区域 | | page 255 |
| Colonne doccia e soffioni doccia Shower bars and shower heads • Duschkombinationen und Kopfbrausen • Colones de douche et douches de tête • Columnas de ducha y rociadores de ducha • Колонны для душа и лейки для душа • 淋浴杆及莲蓬头 | | page 275 |
| Complementi bagno Bathroom complements • Badkomplemente • Compléments bain • Complementos baño • Дополнительные компоненты для ванной комнаты • 浴室组件 | | page 652 |

87.1523.2

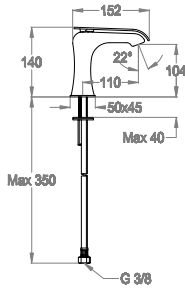

- Miscelatore lavabo h. 140 mm, interasse 110 mm, senza scarico e senza foro per salterello.
- Wash basin mixer, 140 mm high, center distance 110 mm long, without pop-up drain and hole for pull-rod.
- Waschtisch-Einhebelmischer, Höhe 140 mm, Ausladung 110 mm, ohne Ablaufgarnitur und Loch für Zugstange.
- Mitigeur de lavabo, hauteur 140 mm, entraxe 110 mm, sans vidage ni trou pour tirette.
- Monomando de lavabo, altura 140 mm, distancia entre los ejes 110 mm, sin desagüe y sin agujero para tirador.
- Смеситель для умывальника высотой 140 мм, межос.расстояние 110 мм, без слива и без отверстия для выталкивающего механизма донного клапана.
- 面盆龙头，140 mm高，轴间距110 mm，不带提拉去水和拉杆孔。

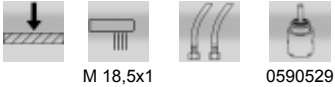

| FINITURA • FINISHING • FARBE • COULEUR • ACABADO • ОТДЕЛКА • 表面处理 | CODICE • CODE • CODE • CODE • CÓDIGO • КОД • 代码 |
|---|---|
| Chrome | 87.1523.2.10.00 |
| Gold Glam | 87.1523.2.18.00 |
| White Mood | 87.1523.2.20.01 |
| Black Coffee | 87.1523.2.30.07 |
| Gold Colour | 87.1523.2.30.13 |

87.1522.5

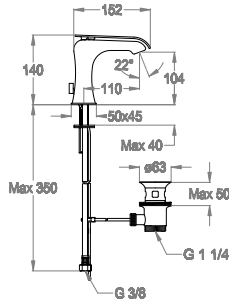

- Miscelatore lavabo h. 140 mm, interasse 110 mm, con scarico e salterello.
- Wash basin mixer 140 mm high, center distance 110 mm long, with pop-up drain and pull-rod.
- Waschtisch-Einhebelmischer, Höhe 140 mm, Ausladung 110 mm, mit Ablaufgarnitur und Zugstange.
- Mitigeur de lavabo, hauteur 140 mm, entraxe 110 mm, avec vidage et tirette.
- Monomando de lavabo, altura 140 mm, distancia entre los ejes 110 mm, con desagüe y tirador completo.
- Смеситель для умывальника высотой 140 мм, межос.расстояние 110 мм, со сливом и донным клапаном.
- 面盆龙头，140 mm高，轴间距110 mm，带提拉去水和拉杆。



| FINITURA • FINISHING • FARBE • COULEUR • ACABADO • ОТДЕЛКА • 表面处理 | CODICE • CODE • CODE • CODE • CÓDIGO • КОД • 代码 |
|---|---|
| Chrome | 87.1522.5.10.00 |
| Gold Glam | 87.1522.5.18.00 |
| White Mood | 87.1522.5.20.01 |
| Black Coffee | 87.1522.5.30.07 |
| Gold Colour | 87.1522.5.30.13 |

87.1521.2

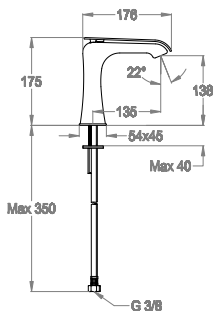

- Miscelatore lavabo h. 175 mm, interasse 135 mm, senza scarico e senza foro per salterello.
- Wash basin mixer, 175 mm high, center distance 135 mm long, without pop-up drain and hole for pull-rod.
- Waschtisch-Einhebelmischer, Höhe 175 mm, Ausladung 135 mm, ohne Ablaufgarnitur und Loch für Zugstange.
- Mitigeur de lavabo, hauteur 175 mm, entraxe 135 mm, sans vidage ni trou pour tirette.
- Monomando de lavabo, altura 175 mm, distancia entre los ejes 135 mm, sin desagüe y sin agujero para tirador.
- Смеситель для умывальника высотой 175 мм, межос.расстояние 135 мм, без слива и без отверстия для выталкивающего механизма донного клапана.
- 面盆龙头，175 mm高，轴间距135 mm，不带提拉去水和拉杆孔。

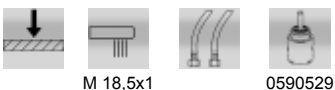

| FINITURA • FINISHING • FARBE • COULEUR • ACABADO • ОТДЕЛКА • 表面处理 | CODICE • CODE • CODE • CODE • CÓDIGO • КОД • 代码 |
|---|---|
| Chrome | 87.1521.2.10.00 |
| Gold Glam | 87.1521.2.18.00 |
| White Mood | 87.1521.2.20.01 |
| Black Coffee | 87.1521.2.30.07 |
| Gold Colour | 87.1521.2.30.13 |

Playone Déco 87

87.1520.5

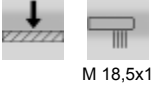
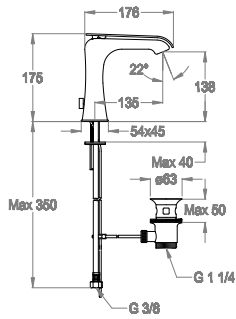

M 18,5x1



0590529 0410040

- Miscelatore lavabo h. 175 mm, interasse 135 mm, con scarico e salterello.
- Wash basin mixer, 175 mm high, center distance 135 mm long, with pop-up drain and pull-rod.
- Waschtisch-Einhebelmischer, Höhe 175 mm, Ausladung 135 mm, mit Ablaufgarnitur und Zugstange.
- Mitigeur de lavabo, hauteur 175 mm, entraxe 135 mm, avec vidage et tirette.
- Monomando de lavabo, altura 175 mm, distancia entre los ejes 135 mm, con desagüe y tirador completo.
- Смеситель для умывальника высотой 175 мм, межос.расстояние 135 мм, со сливом и донным клапаном.
- 面盆龙头, 175 mm高, 轴间距135 mm, 带提拉去水和拉杆。

FINITURA • FINISHING • FARBE • COULEUR • CODICE • CODE • CODE • CODE • ACABADO • ОТДЕЛКА • 表面处理

| FINITURA • FINISHING • FARBE • COULEUR • ACABADO • ОТДЕЛКА • 表面处理 | CODICE • CODE • CODE • CODE • CODIGO • КОД • 代码 |
|---|---|
| Chrome | 87.1520.5.10.00 |
| Gold Glam | 87.1520.5.18.00 |
| White Mood | 87.1520.5.20.01 |
| Black Coffee | 87.1520.5.30.07 |
| Gold Colour | 87.1520.5.30.13 |

87.1524.2

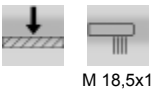
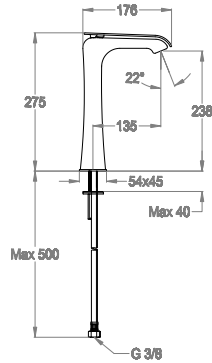

M 18,5x1



0590529

- Miscelatore lavabo h. 275 mm, interasse 135 mm, senza scarico e senza foro per salterello.
- Wash basin mixer, 275 mm high, center distance 135 mm long, without pop-up drain and hole for pull-rod.
- Waschtisch-Einhebelmischer, Höhe 275 mm, Ausladung 135 mm, ohne Ablaufgarnitur und Loch für Zugstange.
- Mitigeur de lavabo, hauteur 275 mm, entraxe 135 mm, sans vidage ni trou pour tirette.
- Monomando de lavabo, altura 275 mm, distancia entre los ejes 135 mm, sin desagüe y sin agujero para tirador.
- Смеситель для умывальника высотой 275 мм, межос.расстояние 135 мм, без слива и без отверстия для выталкивающего механизма донного клапана.
- 面盆龙头, 275 mm高, 轴间距135 mm, 不带提拉去水和拉杆孔。

FINITURA • FINISHING • FARBE • COULEUR • CODICE • CODE • CODE • CODE • ACABADO • ОТДЕЛКА • 表面处理

| FINITURA • FINISHING • FARBE • COULEUR • ACABADO • ОТДЕЛКА • 表面处理 | CODICE • CODE • CODE • CODE • CODIGO • КОД • 代码 |
|---|---|
| Chrome | 87.1524.2.10.00 |
| Gold Glam | 87.1524.2.18.00 |
| White Mood | 87.1524.2.20.01 |
| Black Coffee | 87.1524.2.30.07 |
| Gold Colour | 87.1524.2.30.13 |

87.4653.2

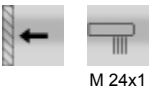
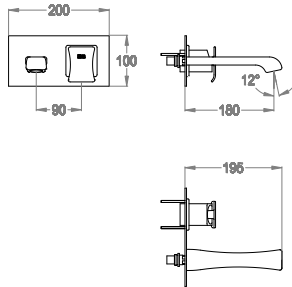

M 24x1



- Parte esterna miscelatore lavabo incasso a parete con piastra, lunghezza 195 mm, interasse 180 mm.
- External part for wall-mounted built-in basin mixer with plate, 195 mm long, center distance 180 mm long.
- Fertigmontageset zu Waschtisch-Einhebelmischer für UP-Montage, mit Abdeckplatte, Länge 195 mm, Ausladung 180 mm.
- Partie extérieure pour mitigeur de lavabo encastré avec plaque, longueur 195 mm, entraxe 180 mm.
- Parte externa para monomando de lavabo empotrable con placa, longitud 195 mm, distancia entre los ejes 180 mm.
- Наружная часть встроенного в стену смесителя для умывальника, с пластиной, длина 195 мм, межос.расстояние 180 мм.
- 外露部件, 用于带面板壁嵌式面盆龙头, 195 mm长, 轴间距180 mm。

FINITURA • FINISHING • FARBE • COULEUR • CODICE • CODE • CODE • CODE • ACABADO • ОТДЕЛКА • 表面处理

| FINITURA • FINISHING • FARBE • COULEUR • ACABADO • ОТДЕЛКА • 表面处理 | CODICE • CODE • CODE • CODE • CODIGO • КОД • 代码 |
|---|---|
| Chrome | 87.4653.2.10.00 |
| Gold Glam | 87.4653.2.18.00 |
| White Mood | 87.4653.2.20.01 |
| Black Coffee | 87.4653.2.30.07 |
| Gold Colour | 87.4653.2.30.13 |

Articoli complementari necessari
Necessary complementary items
Notwendige komplementäre Artikel
Articles complémentaires nécessaires
Artículos complementarios necesarios
Необходимые дополнительные предметы
必须的配套产品

05.8035.4



page 726

- Parte incasso miscelatore a parete ad una uscita.
- Built-in part for wall-mounted one-way mixer.
- UP-Einbaukörper für Einweg-Einhebelmischer.
- Partie encastrée pour mitigeur à une sortie.
- Parte empotrable mezclador monomando una salida.
- Встроенная часть одноходового смесителя.
- 壁装式单出水口龙头的预埋件。

FINITURA • FINISHING • FARBE • COULEUR • CODICE • CODE • CODE • CODE • ACABADO • ОТДЕЛКА • 表面处理

| FINITURA • FINISHING • FARBE • COULEUR • ACABADO • ОТДЕЛКА • 表面处理 | CODICE • CODE • CODE • CODE • CODIGO • КОД • 代码 |
|---|---|
| Raw Brass | 05.8035.4.05.00 |

87.4651.2

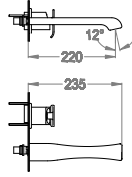
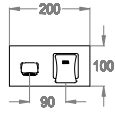

- Parte esterna miscelatore lavabo incasso a parete con piastra, lunghezza 235 mm, interasse 220 mm.
- External part for wall-mounted built-in basin mixer with plate, 235 mm long, center distance 220 mm long.
- Fertigmontageset zu Waschtisch-Einhebelmischer für UP-Montage, mit Abdeckplatte, Länge 235 mm, Ausladung 220 mm.
- Partie extérieure pour mitigeur de lavabo encastré avec plaque, longueur 235 mm, entraxe 220 mm.
- Parte externa para monomando de lavabo empotrable con placa, longitud 235 mm, distancia entre los ejes 220 mm.
- Наружная часть встроенного в стену смесителя для умывальника, с пластиной, длина 235 мм, межос.расстояние 220 мм.
- 外露部件，用于带面板壁嵌式面盆龙头，235 mm长，轴间距220 mm。



Articoli complementari necessari
Necessary complementary items
Notwendige komplementäre Artikel
Articles complémentaires nécessaires
Artículos complementarios necesarios
Необходимые дополнительные предметы
必须的配套产品

05.8035.4



page 726

- Parte incasso miscelatore a parete ad una uscita.
- Built-in part for wall-mounted one-way mixer.
- UP-Einbaukörper für Einweg-Einhebelmischer.
- Partie encastrée pour mitigeur à une sortie.
- Parte empotrable mezclador monomando una salida.
- Встроенная часть одноходового смесителя.
- 壁装式单出水口龙头的预埋件。

| FINITURA • FINISHING • FARBE • COULEUR • ACABADO • ОТДЕЛКА • 表面处理 | CODICE • CODE • CODE • CODE • CÓDIGO • КОД • 代码 |
|---|---|
| Chrome | 87.4651.2.10.00 |
| Gold Glam | 87.4651.2.18.00 |
| White Mood | 87.4651.2.20.01 |
| Black Coffee | 87.4651.2.30.07 |
| Gold Colour | 87.4651.2.30.13 |

| FINITURA • FINISHING • FARBE • COULEUR • ACABADO • ОТДЕЛКА • 表面处理 | CODICE • CODE • CODE • CODE • CÓDIGO • КОД • 代码 |
|---|---|
| Raw Brass | 05.8035.4.05.00 |

87.4635.2

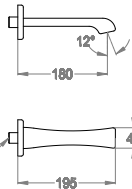
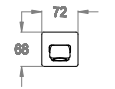

- Bocca di erogazione a parete, ingresso acqua 1/2", interasse 180 mm, lunghezza 195 mm.
- Wall-mounted water spout 1/2", center distance 180 mm long, complete length 195 mm.
- Wandauslauf 1/2", Ausladung 180 mm, Länge 195 mm.
- Bec mural, arrivée d'eau 1/2", entraxe 180 mm, longueur 195 mm.
- Caño mural, entrada agua 1/2", distancia entre los ejes 180 mm, longitud 195 mm.
- Настенный излив, выпуск воды 1/2", межос.расстояние 180 мм, длина 195 мм.
- 壁装式水嘴1/2"，轴间距180 mm，195 mm长。



87.4634.2

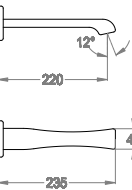
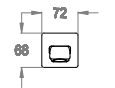

- Bocca di erogazione a parete, ingresso acqua 1/2", interasse 220 mm, lunghezza 235 mm.
- Wall-mounted water spout 1/2", center distance 220 mm long, complete length 235 mm.
- Wandauslauf 1/2", Ausladung 220 mm, Länge 235 mm.
- Bec mural, arrivée d'eau 1/2", entraxe 220 mm, longueur 235 mm.
- Caño mural, entrada agua 1/2", distancia entre los ejes 220 mm, longitud 235 mm.
- Настенный излив, выпуск воды 1/2", межос.расстояние 220 мм, длина 235 мм.
- 壁装式水嘴1/2"，轴间距220 mm，235 mm长。



| FINITURA • FINISHING • FARBE • COULEUR • ACABADO • ОТДЕЛКА • 表面处理 | CODICE • CODE • CODE • CODE • CÓDIGO • КОД • 代码 |
|---|---|
| Chrome | 87.4635.2.10.00 |
| Gold Glam | 87.4635.2.18.00 |
| White Mood | 87.4635.2.20.01 |
| Black Coffee | 87.4635.2.30.07 |
| Gold Colour | 87.4635.2.30.13 |

| FINITURA • FINISHING • FARBE • COULEUR • ACABADO • ОТДЕЛКА • 表面处理 | CODICE • CODE • CODE • CODE • CÓDIGO • КОД • 代码 |
|---|---|
| Chrome | 87.4634.2.10.00 |
| Gold Glam | 87.4634.2.18.00 |
| White Mood | 87.4634.2.20.01 |
| Black Coffee | 87.4634.2.30.07 |
| Gold Colour | 87.4634.2.30.13 |

85.4633.2

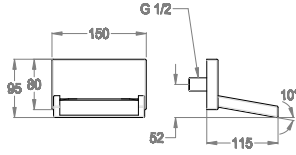

- Bocca di erogazione a cascata a parete, ingresso acqua 1/2", lunghezza 115 mm.
- Wall-mounted waterfall spout 1/2", 115 mm long.
- Wasserfall-Auslauf, 1/2", zur Wandmontage, Länge 115 mm.
- Bec cascade mural, arrivée d'eau 1/2", longueur 115 mm.
- Caño en cascada mural, entrada agua 1/2", longitud 115 mm.
- Настенный каскадный излив для умывальника, выпуск воды 1/2", длина 115 мм.
- 壁装式瀑布水嘴1/2" , 115 mm长。

| FINITURA • FINISHING • FARBE • COULEUR • ACABADO • ОТДЕЛКА • 表面处理 | CODICE • CODE • CODE • CODE • CODIGO • КОД • 代码 |
|---|---|
| Chrome | 85.4633.2.10.00 |
| Gold Glam | 85.4633.2.18.00 |
| Black Coffee | 85.4633.2.30.07 |
| Gold Colour | 85.4633.2.30.13 |



85.4920.2

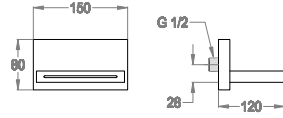

- Bocca di erogazione a parete, ingresso acqua 1/2", lunghezza 120 mm.
- Wall-mounted water spout 1/2", 120 mm long.
- Wandauslauf 1/2", Länge 120 mm.
- Bec mural, arrivée d'eau 1/2", longueur 120 mm.
- Caño mural, entrada agua 1/2", longitud 120 mm.
- Настенный излив, выпуск воды 1/2", длина 120 мм.
- 壁装式水嘴1/2" , 120 mm长。

| FINITURA • FINISHING • FARBE • COULEUR • ACABADO • ОТДЕЛКА • 表面处理 | CODICE • CODE • CODE • CODE • CODIGO • КОД • 代码 |
|---|---|
| Chrome | 85.4920.2.10.00 |
| Gold Glam | 85.4920.2.18.00 |
| Black Coffee | 85.4920.2.30.07 |
| Gold Colour | 85.4920.2.30.13 |

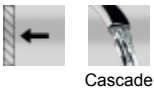

87.1486.2

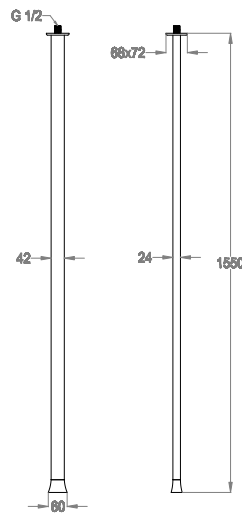

- Bocca di erogazione a soffitto, ingresso acqua 1/2", lunghezza 1550 mm.
- Ceiling-mounted water spout 1/2", 1550 mm long.
- Deckenauslauf, 1/2", Länge 1550 mm.
- Bec au plafond, arrivée d'eau 1/2", longueur 1550 mm.
- Caño para montaje al techo, entrada agua 1/2", longitud 1550 mm.
- Потолочный излив, выпуск воды 1/2", длина 1550 мм.
- 吊顶式水嘴1/2" , 1550 mm长。

| FINITURA • FINISHING • FARBE • COULEUR • ACABADO • ОТДЕЛКА • 表面处理 | CODICE • CODE • CODE • CODE • CODIGO • КОД • 代码 |
|---|---|
| Chrome | 87.1486.2.10.00 |
| White Mood | 87.1486.2.20.01 |



Playone Déco 87

87.1473.2

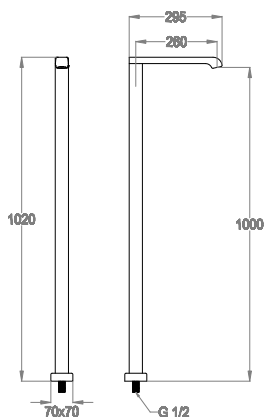

- Bocca di erogazione a pavimento, ingresso acqua 1/2", interasse 260 mm, h. 1000 mm.
- Floor-mounted water spout 1/2", center distance 260 mm, 1000 mm high.
- Bodenstehender Auslauf, 1/2", Ausladung 260 mm, Höhe 1000 mm.
- Bec sur sol, arrivée d'eau 1/2", entraxe 260 mm, hauteur 1000 mm.
- Caño para montaje al suelo, entrada agua 1/2", distancia entre los ejes 260 mm, altura 1000 mm.
- Напольный излив, выпуск воды 1/2", межос.расстояние 260 мм, высотой 1000 мм.
- 落地式水嘴1/2", 轴间距260 mm, 1000 mm高。

| FINITURA • FINISHING • FARBE • COULEUR • ACABADO • ОТДЕЛКА • 表面处理 | CODICE • CODE • CODE • CODE • CODIGO • КОД • 代码 |
|---|---|
| Chrome | 87.1473.2.10.00 |
| White Mood | 87.1473.2.20.01 |



M 24x1

87.1616.2

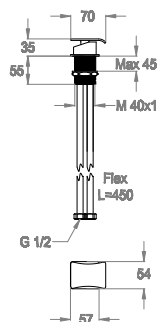

- Miscelatore al piano per bocca di erogazione.
- Deck-mounted mixer for water spout.
- Einhebelmischer für Auslauf.
- Mitigeur sur plan pour bec.
- Mezclador de encimera para caño.
- Настольный смеситель к изливу.
- 台装式龙头的水嘴。

| FINITURA • FINISHING • FARBE • COULEUR • ACABADO • ОТДЕЛКА • 表面处理 | CODICE • CODE • CODE • CODE • CODIGO • КОД • 代码 |
|---|---|
| Chrome | 87.1616.2.10.00 |
| Gold Glam | 87.1616.2.18.00 |
| White Mood | 87.1616.2.20.01 |
| Black Coffee | 87.1616.2.30.07 |
| Gold Colour | 87.1616.2.30.13 |



G 1/2 (F) G 1/2 (F) 0590536

87.1625.2

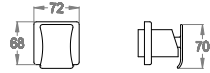

- Parte esterna miscelatore incasso a parete.
- External part for wall-mounted built-in mixer.
- Fertigmontageset zu UP-Einhebelmischer.
- Partie extérieure pour mitigeur encastré mural.
- Parte externa mezclador monomando empotrable.
- Наружная часть встроенного в стену смесителя.
- 壁嵌式龙头的外露部件。

| FINITURA • FINISHING • FARBE • COULEUR • ACABADO • ОТДЕЛКА • 表面处理 | CODICE • CODE • CODE • CODE • CODIGO • КОД • 代码 |
|---|---|
| Chrome | 87.1625.2.10.00 |
| Gold Glam | 87.1625.2.18.00 |
| White Mood | 87.1625.2.20.01 |
| Black Coffee | 87.1625.2.30.07 |
| Gold Colour | 87.1625.2.30.13 |



Articoli complementari necessari
Necessary complementary items
Notwendige komplementäre Artikel
Articles complémentaires nécessaires
Artículos complementarios necesarios
Необходимые дополнительные предметы
必须的配套产品

05.2430.4

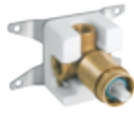

page 725

- Parte incasso miscelatore a parete ad una uscita.
- Built-in part for wall-mounted one-way mixer.
- UP-Einbaukörper für Einweg-Einhebelmischer.
- Partie encastrée pour mitigeur à une sortie.
- Parte empotrable mezclador monomando una salida.
- Встроенная часть одноходового смесителя.
- 壁装式单出水口龙头的预埋件。

| FINITURA • FINISHING • FARBE • COULEUR • ACABADO • ОТДЕЛКА • 表面处理 | CODICE • CODE • CODE • CODE • CODIGO • КОД • 代码 |
|---|---|
| Raw Brass | 05.2430.4.05.00 |

| | |
|---|----------|
| Area lavabo Wash basin area • Waschtisch-Bereich • Zone du lavabo • Área lavabo • Zona умывальника • 面盆区域 | page 249 |
| Area bidet/WC Bidet/WC area • Bidet/WC-Bereich • Zone du bidet/WC • Área bidé/WC • Zona биде/унитаз • 净身盆/厕所区域 | page 254 |
| Area vasca/doccia Bath/shower area • Badewannen-Duschbereich • Zone de la baignoire/de douche • Área bañera/ducha • Zona ванны/душа • 浴缸/淋浴区域 | page 255 |
| Colonne doccia e soffioni doccia Shower bars and shower heads • Duschkombinationen und Kopfbrausen • Colonnes de douche et douches de tête • Columnas de ducha y rociadores de ducha • Колонны для душа и лейки для душа • 淋浴杆及莲蓬头 | page 275 |
| Complementi bagno Bathroom complements • Badkomplemente • Compléments bain • Complementos baño • Дополнительные компоненты для ванной комнаты • 浴室组件 | page 652 |

87.2520.5

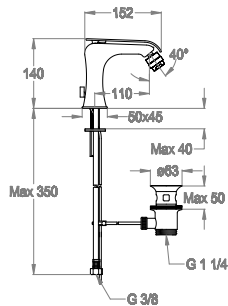

- Miscelatore bidet h. 140 mm, interasse 110 mm, con scarico e salterello.
- Bidet mixer, 140 mm high, center distance 110 mm long, with pop-up drain and pull-rod.
- Bidet-Einhebelmischer Höhe 140 mm, Ausladung 110 mm, mit Ablaufgarnitur und Zugstange.
- Mitigeur de bidet hauteur 140 mm, entraxe 110 mm, avec vidage et tirette.
- Monomando bidé altura 140 mm, distancia entre los ejes 110 mm, con desagüe y tirador completo.
- Смеситель для биде высотой 140 мм, межос.расстояние 110 мм, со сливом и донным клапаном.
- 净身盆龙头，140 mm高，轴间距110 mm，带提拉去水和拉杆。

| FINITURA • FINISHING • FARBE • COULEUR • ACABADO • ОТДЕЛКА • 表面处理 | CODICE • CODE • CODE • CODE • CODIGO • КОД • 代码 |
|---|---|
| Chrome | 87.2520.5.10.00 |
| Gold Glam | 87.2520.5.18.00 |
| White Mood | 87.2520.5.20.01 |
| Black Coffee | 87.2520.5.30.07 |
| Gold Colour | 87.2520.5.30.13 |



M 18x1

0590529

0410040

➤ 87.5944.3

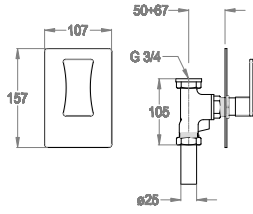

- Passo rapido incasso, ingresso acqua 3/4".
- 3/4" Built-in flush valve.
- UP-Spülventil 3/4".
- Robinet encastré pour WC, arrivée d'eau 3/4".
- Paso rápido empotrable, entrada agua 3/4".
- Встроенный кран для унитаза 3/4".
- 3/4"嵌入式冲水阀。

| FINITURA • FINISHING • FARBE • COULEUR • ACABADO • ОТДЕЛКА • 表面处理 | CODICE • CODE • CODE • CODE • CÓDIGO • КОД • 代码 |
|---|---|
| Chrome | 87.5944.3.10.00 |
| Gold Glam | 87.5944.3.18.00 |
| White Mood | 87.5944.3.20.01 |

➤ 87.5944.4

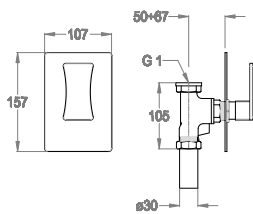

- Passo rapido incasso, ingresso acqua 1".
- 1" Built-in flush valve.
- UP-Spülventil 1".
- Robinet encastré pour WC, arrivée d'eau 1".
- Paso rápido empotrable, entrada agua 1".
- Встроенный кран для унитаза 1".
- 1"嵌入式冲水阀。

| FINITURA • FINISHING • FARBE • COULEUR • ACABADO • ОТДЕЛКА • 表面处理 | CODICE • CODE • CODE • CODE • CÓDIGO • КОД • 代码 |
|---|---|
| Chrome | 87.5944.4.10.00 |
| Gold Glam | 87.5944.4.18.00 |
| White Mood | 87.5944.4.20.01 |



| | |
|--|-----------------|
| Area lavabo Wash basin area • Waschtisch-Bereich • Zone du lavabo • Área lavabo • Зона умывальника • 面盆区域 | page 249 |
| Area bidet/WC Bidet/WC area • Bidet/WC-Bereich • Zone du bidet/WC • Área bidé/WC • Зона биде/унитаза • 净身盆/厕所区域 | page 254 |
| Area vasca/doccia Bath/shower area • Badewannen-Duschbereich • Zone de la baignoire/de douche • Área bañera/ducha • Зона ванны/душа • 浴缸/淋浴区域 | page 255 |
| Colonne doccia e soffioni doccia Shower bars and shower heads • Duschkombinationen und Kopfbrausen • Colonnes de douche et douches de tête. • Columnas de ducha y rociadores de ducha • Колонны для душа и лейки для душа • 淋浴杆及莲蓬头 | page 275 |
| Complementi bagno Bathroom complements • Badkomplemente • Compléments bain • Complementos baño • Дополнительные компоненты для ванной комнаты • 浴室组件 | page 652 |

➤ 87.3338.2

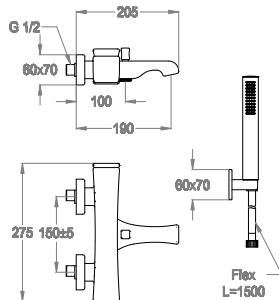

- Miscelatore vasca esterno a parete con deviatore e doccia duplex.
- Wall-mounted bath mixer with diverter and shower set.
- AP-Wannenfüll- und Brausearmatur mit Umstellventil und Brausegarnitur.
- Mitigeur bain/douche mural avec inverseur et ensemble douche.
- Mezclador monomando para baño/ducha mural con inversor y ducha de mano duplex.
- Смеситель наружный настенный для ванной с переключателем и душем дуплекс.
- 带分流阀和手持花洒的壁装式浴缸龙头。

| FINITURA • FINISHING • FARBE • COULEUR • ACABADO • ОТДЕЛКА • 表面处理 | CODICE • CODE • CODE • CODE • CÓDIGO • КОД • 代码 |
|---|---|
| Chrome | 87.3338.2.10.00 |
| Gold Glam | 87.3338.2.18.00 |
| White Mood | 87.3338.2.20.01 |



87.3337.2

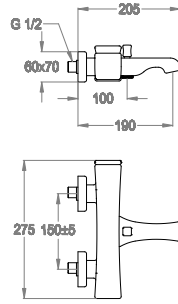

- Miscelatore vasca esterno a parete con deviatore e attacco flex.
- Wall-mounted bath mixer with diverter and flex hose connection.
- AP-Wannenfüll- und Brausearmatur mit Umstellventil und Verbindung für Brauseschlauch.
- Mitigeur bain/douche mural avec inverseur et raccord flexible.
- Mezclador monomando para baño/ducha mural con inversor y conexión flex.
- Смеситель наружный настенный для ванной с переключателем и гибким креплением.
- 带分流阀和软管接头的壁装式浴缸龙头。



| FINITURA • FINISHING • FARBE • COULEUR • ACABADO • ОТДЕЛКА • 表面处理 | CODICE • CODE • CODE • CODE • CODIGO • КОД • 代码 |
|---|---|
| Chrome | 87.3337.2.10.00 |
| Gold Glam | 87.3337.2.18.00 |
| White Mood | 87.3337.2.20.01 |

87.4138.2

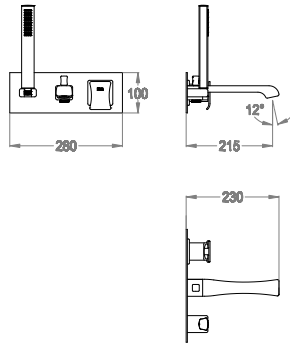

- Parte esterna miscelatore vasca incasso a parete con piastra, deviatore e doccetta duplex.
- External part for wall-mounted built-in bath mixer with plate, diverter and hand shower.
- Fertigmontageset zu UP-Wannenfüll- und Brausearmatur mit Abdeckplatte, Umstellventil und Brausegarnitur.
- Partie extérieure pour mitigeur de bain/douche encastré avec plaque, inverseur et ensemble douche.
- Parte externa mezclador monomando baño/ducha empotrable con placa, inversor y ducha de mano duplex.
- Наружная часть встроенного смесителя для ванной с пластиной, переключателем и душем дуплекс.
- 外露部件，用于带面板、分流阀和手持花洒的嵌入式浴缸龙头。



| FINITURA • FINISHING • FARBE • COULEUR • ACABADO • ОТДЕЛКА • 表面处理 | CODICE • CODE • CODE • CODE • CODIGO • КОД • 代码 |
|---|---|
| Chrome | 87.4138.2.10.00 |
| Gold Glam | 87.4138.2.18.00 |
| White Mood | 87.4138.2.20.01 |

Articoli complementari necessari
Necessary complementary items
Notwendige komplementäre Artikel
Articles complémentaires nécessaires
Artículos complementarios necesarios
Необходимые дополнительные предметы
必须的配套产品

05.8035.4



page 726

- Parte incasso miscelatore a parete ad una uscita.
- Built-in part for wall-mounted one-way mixer.
- UP-Einbaukörper für Einweg-Einhebelmischer.
- Partie encastrée pour mitigeur à une sortie.
- Parte empotrable mezclador monomando una salida.
- Встроенная часть одноходового смесителя.
- 壁装式单出水口龙头的预埋件。

| FINITURA • FINISHING • FARBE • COULEUR • ACABADO • ОТДЕЛКА • 表面处理 | CODICE • CODE • CODE • CODE • CODIGO • КОД • 代码 |
|---|---|
| Raw Brass | 05.8035.4.05.00 |

87.4835.2

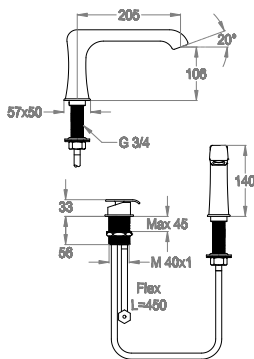

- Gruppo bordo vasca a due fori al piano.
- Two-hole deck-mounted bath mixer.
- Zweiloch-Wannenrandarmatur.
- Mitigeur deux trous pour bord de baignoire.
- Monomando de encimera a dos agujeros.
- Комплект для установки на борту ванной с двумя отверстиями.
- 两孔台装式浴缸套装。



| FINITURA • FINISHING • FARBE • COULEUR • ACABADO • ОТДЕЛКА • 表面处理 | CODICE • CODE • CODE • CODE • CODIGO • КОД • 代码 |
|---|---|
| Chrome | 87.4835.2.10.00 |
| Gold Glam | 87.4835.2.18.00 |
| White Mood | 87.4835.2.20.01 |
| Black Coffee | 87.4835.2.30.07 |
| Gold Colour | 87.4835.2.30.13 |

Playone Déco 87

87.4843.2

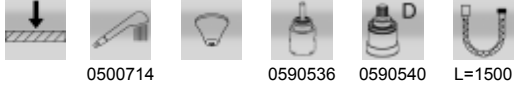
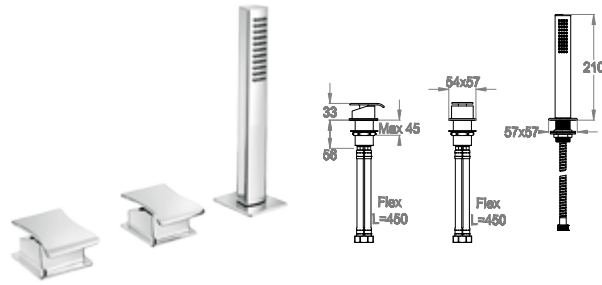

- Gruppo bordo vasca a tre fori al piano, con deviatore e doccia duplex, senza bocca.
- Three-hole deck-mounted bath mixer with diverter and shower set, without spout.
- Dreiloch-Wannenrandarmatur mit Umstellventil und Schlupfbrause, ohne Auslauf.
- Mitigeur trois trous pour bord de baignoire avec inverseur et ensemble douche, sans bec.
- Monomando de encimera a tres agujeros con inversor y ducha de mano duplex, sin caño.
- Комплект для установки на борту ванной с тремя отверстиями, с переключателем и душем дуплекс, без излива.
- 带分流阀和手持花洒的三孔台装式浴缸套装, 不含水嘴。

| FINITURA • FINISHING • FARBE • COULEUR • ACABADO • ОТДЕЛКА • 表面处理 | CODICE • CODE • CODE • CODE • CODIGO • КОД • 代码 |
|---|---|
| Chrome | 87.4843.2.10.00 |
| Gold Glam | 87.4843.2.18.00 |
| White Mood | 87.4843.2.20.01 |
| Black Coffee | 87.4843.2.30.07 |
| Gold Colour | 87.4843.2.30.13 |

87.4855.2

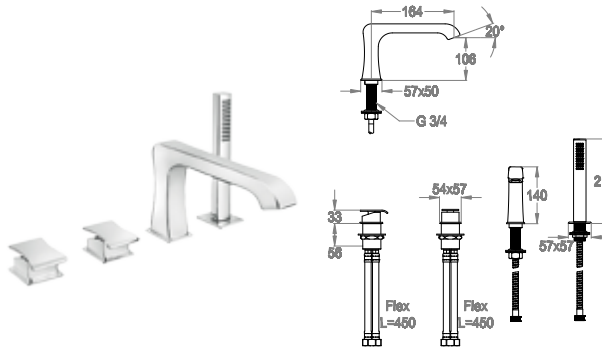

- Gruppo bordo vasca a quattro fori al piano, con deviatore e doccia duplex.
- Four-hole deck-mounted bath mixer with diverter and shower set.
- Vierloch-Wannenrandarmatur, mit Umstellventil und Schlupfbrause.
- Mitigeur quatre trous pour bord de baignoire avec inverseur et ensemble douche.
- Monomando de encimera a cuatro agujeros con inversor y ducha de mano duplex.
- Комплект для установки на борту ванной с четырьмя отверстиями, с переключателем и душем дуплекс.
- 带分流阀和手持花洒的四孔台装瀑布式浴缸套装。

| FINITURA • FINISHING • FARBE • COULEUR • ACABADO • ОТДЕЛКА • 表面处理 | CODICE • CODE • CODE • CODE • CODIGO • КОД • 代码 |
|---|---|
| Chrome | 87.4855.2.10.00 |
| Gold Glam | 87.4855.2.18.00 |
| White Mood | 87.4855.2.20.01 |
| Black Coffee | 87.4855.2.30.07 |
| Gold Colour | 87.4855.2.30.13 |

05.0080.0

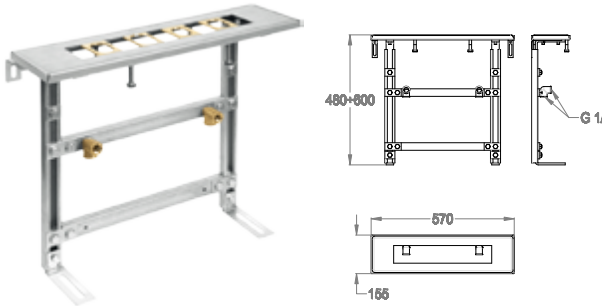

- Sistema di montaggio per bordo vasca con fissaggio a pavimento.
- Assembly system for deck-mounted bath mixer with floor fixing.
- Montagesystem für Wannenrand mit Befestigung am Boden.
- Système de montage pour bord de baignoire avec fixation au sol.
- Sistema de montaje para borde bañera con fijación en el suelo.
- Система установки на борту ванной с напольным креплением.
- 带地台固定的台装式浴缸龙头组装套件。

| FINITURA • FINISHING • FARBE • COULEUR • ACABADO • ОТДЕЛКА • 表面处理 | CODICE • CODE • CODE • CODE • CODIGO • КОД • 代码 |
|---|---|
| Raw Brass | 05.0080.0.05.00 |

05.0081.0

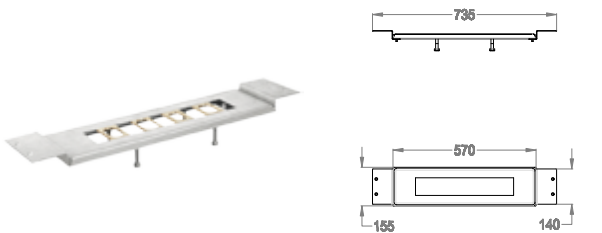

- Sistema di montaggio per bordo vasca con fissaggio al piano.
- Assembly system for deck-mounted bath mixer with deck fixing.
- Montagesystem für Wannenrand mit Befestigung am Rand.
- Système de montage pour bord de baignoire avec fixation sur plan.
- Sistema de montaje para borde bañera con fijación en la encimera.
- Система установки на борту ванной с настольным креплением.
- 带台上固定的台装式浴缸龙头组装套件。

| FINITURA • FINISHING • FARBE • COULEUR • ACABADO • ОТДЕЛКА • 表面处理 | CODICE • CODE • CODE • CODE • CODIGO • КОД • 代码 |
|---|---|
| Raw Brass | 05.0081.0.05.00 |

87.3305.2

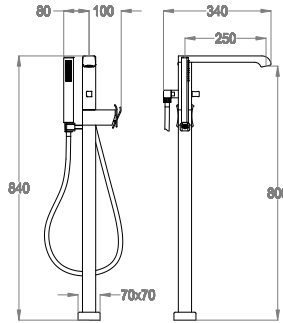

- Parte esterna miscelatore bordo vasca a pavimento, con deviatore e doccia duplex.
- External part for floor-mounted bath mixer, with diverter and shower set.
- Fertigmontageset zu bodenstehendem Wannen-Einhebelmischer mit Umstellventil und Brausegarnitur.
- Partie extérieure pour mitigeur bain pour montage sur sol, avec inverseur et ensemble douche.
- Parte externa monomando de bañera al suelo con inversor y ducha de mano duplex.
- Наружная часть смесителя напольного на борт ванны, с переключателем и душем дуплекс.
- 外露部件，用于带分流阀和手持花洒的落地式浴缸龙头。

| FINITURA • FINISHING • FARBE • COULEUR • ACABADO • ОТДЕЛКА • 表面处理 | CODICE • CODE • CODE • CODE • CODIGO • КОД • 代码 |
|---|---|
| Chrome | 87.3305.2.10.00 |
| White Mood | 87.3305.2.20.01 |



M 24x1 0540087 0590526

Articoli complementari necessari
Necessary complementary items
Notwendige komplementäre Artikel
Articles complémentaires nécessaires
Artículos complementarios necesarios
Необходимые дополнительные предметы
必须的配套产品

05.2145.4

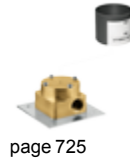

page 725

- Parte incasso miscelatore.
- Built-in part for mixer.
- UP-Einbaukörper zu Einhebelmischer.
- Partie encastrée pour mitigeur.
- Parte empotrable para mezclador monomando.
- Встроенная часть смесителя.
- 龙头的预埋件。

| FINITURA • FINISHING • FARBE • COULEUR • ACABADO • ОТДЕЛКА • 表面处理 | CODICE • CODE • CODE • CODE • CODIGO • КОД • 代码 |
|---|---|
| Raw Brass | 05.2145.4.05.00 |

87.4635.3

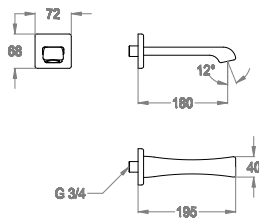

- Bocca di erogazione a parete, ingresso acqua 3/4", interasse 180 mm, lunghezza 195 mm.
- Wall-mounted water spout 3/4", center distance 180 mm long, complete length 195 mm.
- Wandauslauf 3/4", Ausladung 180 mm, Länge 195 mm.
- Bec mural, arrivée d'eau 3/4", entraxe 180 mm, longueur 195 mm.
- Caño mural, entrada agua 3/4", distancia entre los ejes 180 mm, longitud 195 mm.
- Настенный излив, выпуск воды 3/4", межос.расстояние 180 мм, длина 195 мм.
- 壁装式水嘴3/4"，轴间距180 mm，195 mm长。

| FINITURA • FINISHING • FARBE • COULEUR • ACABADO • ОТДЕЛКА • 表面处理 | CODICE • CODE • CODE • CODE • CODIGO • КОД • 代码 |
|---|---|
| Chrome | 87.4635.3.10.00 |
| Gold Glam | 87.4635.3.18.00 |
| White Mood | 87.4635.3.20.01 |
| Black Coffee | 87.4635.3.30.07 |
| Gold Colour | 87.4635.3.30.13 |

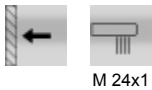

M 24x1

Playone Déco 87

➤ 87.4634.3

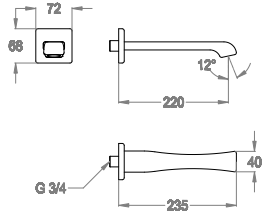

- Bocca di erogazione a parete, ingresso acqua 3/4", interasse 220 mm, lunghezza 235 mm.
- Wall-mounted water spout 3/4", center distance 220 mm long, complete length 235 mm.
- Wandauslauf 3/4", Ausladung 220 mm, Länge 235 mm.
- Bec mural, arrivée d'eau 3/4", entraxe 220 mm, longueur 235 mm.
- Caño mural, entrada agua 3/4", distancia entre los ejes 220 mm, longitud 235 mm.
- Настенный излив, выпуск воды 3/4", межос.расстояние 220 мм, длина 235 мм.
- 壁装式水嘴3/4", 轴间距220 mm, 235 mm长。



| FINITURA • FINISHING • FARBE • COULEUR • ACABADO • ОТДЕЛКА • 表面处理 | CODICE • CODE • CODE • CODE • CÓDIGO • КОД • 代码 |
|---|---|
| Chrome | 87.4634.3.10.00 |
| Gold Glam | 87.4634.3.18.00 |
| White Mood | 87.4634.3.20.01 |
| Black Coffee | 87.4634.3.30.07 |
| Gold Colour | 87.4634.3.30.13 |

➤ 85.4633.3

NEW

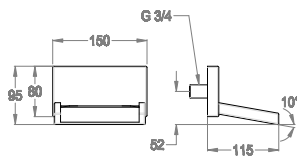

- Bocca di erogazione a cascata a parete, ingresso acqua 3/4", lunghezza 115 mm.
- Wall-mounted waterfall spout 3/4", 115 mm long.
- Wasserfall-Auslauf, 3/4", zur Wandmontage, Länge 115 mm.
- Bec cascade mural, arrivée d'eau 3/4", longueur 115 mm.
- Caño en cascada mural, entrada agua 3/4", longitud 115 mm.
- Настенный каскадный излив для умывальника, выпуск воды 3/4", длина 115 мм.
- 壁装式瀑布水嘴3/4", 115 mm长。

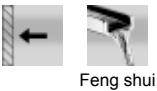

| FINITURA • FINISHING • FARBE • COULEUR • ACABADO • ОТДЕЛКА • 表面处理 | CODICE • CODE • CODE • CODE • CÓDIGO • КОД • 代码 |
|---|---|
| Chrome | 85.4633.3.10.00 |
| Gold Glam | 85.4633.3.18.00 |
| Black Coffee | 85.4633.3.30.07 |
| Gold Colour | 85.4633.3.30.13 |

➤ 85.4920.3

NEW

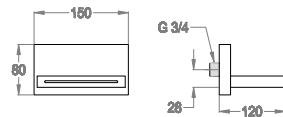

- Bocca di erogazione a parete, ingresso acqua 3/4", lunghezza 120 mm.
- Wall-mounted water spout 3/4", 120 mm long.
- Wandauslauf 3/4", Länge 120 mm.
- Bec mural, arrivée d'eau 3/4", longueur 120 mm.
- Caño mural, entrada agua 3/4", longitud 120 mm.
- Настенный излив, выпуск воды 3/4", длина 120 мм.
- 壁装式水嘴3/4", 120 mm长。

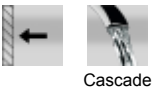

| FINITURA • FINISHING • FARBE • COULEUR • ACABADO • ОТДЕЛКА • 表面处理 | CODICE • CODE • CODE • CODE • CÓDIGO • КОД • 代码 |
|---|---|
| Chrome | 85.4920.3.10.00 |
| Gold Glam | 85.4920.3.18.00 |
| Black Coffee | 85.4920.3.30.07 |
| Gold Colour | 85.4920.3.30.13 |

➤ 87.1489.2

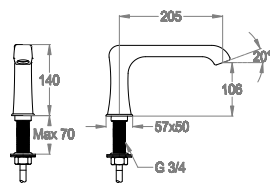

- Bocca di erogazione al piano, interasse 205 mm, h. 140 mm.
- Deck-mounted water spout, center distance 205 mm long, 140 mm high.
- Wasserauslauf, Ausladung 205 mm, Höhe 140 mm.
- Bec sur plan, entraxe 205 mm, hauteur 140 mm.
- Caño de encimera, distancia entre los ejes 205 mm, altura 140 mm.
- Настольный излив, выпуск воды, межос.расстояние 205 мм, высотой 140 мм.
- 台装式水嘴, 轴间距205 mm, 140 mm高。

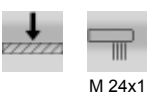

| FINITURA • FINISHING • FARBE • COULEUR • ACABADO • ОТДЕЛКА • 表面处理 | CODICE • CODE • CODE • CODE • CÓDIGO • КОД • 代码 |
|---|---|
| Chrome | 87.1489.2.10.00 |
| Gold Glam | 87.1489.2.18.00 |
| White Mood | 87.1489.2.20.01 |
| Black Coffee | 87.1489.2.30.07 |
| Gold Colour | 87.1489.2.30.13 |

05.4787.1 **NEW**

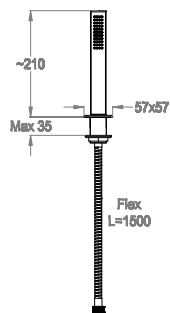

- Doccetta bordo vasca.
- Deck-mounted hand shower.
- Schlupfbrause.
- Douchette bord baignoire.
- Ducha de mano bañera.
- Душевая лейка на борт ванной.
- 缸边手持花洒。

FINITURA • FINISHING • FARBE • COULEUR • CODICE • CODE • CODE • CODE • ACABADO • ОТДЕЛКА • 表面处理 CODIGO • КОД • 代码

| | |
|--------------|-----------------|
| Chrome | 05.4787.1.10.00 |
| Gold Glam | 05.4787.1.18.00 |
| White Mood | 05.4787.1.20.01 |
| Black Coffee | 05.4787.1.30.07 |
| Gold Colour | 05.4787.1.30.13 |



87.1616.2

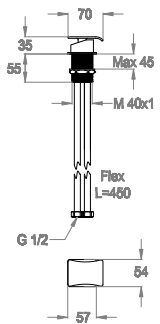

- Miscelatore al piano per bocca di erogazione.
- Deck-mounted mixer for water spout.
- Einhebelmischer für Auslauf.
- Mitigeur sur plan pour bec.
- Mezclador de encimera para saño.
- Настольный смеситель к изливу.
- 台装式龙头的水嘴。

FINITURA • FINISHING • FARBE • COULEUR • CODICE • CODE • CODE • CODE • ACABADO • ОТДЕЛКА • 表面处理 CODIGO • КОД • 代码

| | |
|--------------|-----------------|
| Chrome | 87.1616.2.10.00 |
| Gold Glam | 87.1616.2.18.00 |
| White Mood | 87.1616.2.20.01 |
| Black Coffee | 87.1616.2.30.07 |
| Gold Colour | 87.1616.2.30.13 |



87.1625.2



- Parte esterna miscelatore incasso a parete.
- External part for wall-mounted built-in mixer.
- Fertigmontageset zu UP-Einhebelmischer.
- Partie extérieure pour mitigeur encastré mural.
- Parte externa mezclador monomando emprotrable.
- Наружная часть встроенного в стену смесителя.
- 壁嵌式龙头的外露部件。

FINITURA • FINISHING • FARBE • COULEUR • CODICE • CODE • CODE • CODE • ACABADO • ОТДЕЛКА • 表面处理 CODIGO • КОД • 代码

| | |
|--------------|-----------------|
| Chrome | 87.1625.2.10.00 |
| Gold Glam | 87.1625.2.18.00 |
| White Mood | 87.1625.2.20.01 |
| Black Coffee | 87.1625.2.30.07 |
| Gold Colour | 87.1625.2.30.13 |



Articoli complementari necessari
Necessary complementary items
Notwendige komplementäre Artikel
Articles complémentaires nécessaires
Artículos complementarios necesarios
Необходимые дополнительные предметы
必须的配套产品

05.2430.4

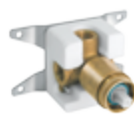

page 725

- Parte incasso miscelatore a parete ad una uscita.
- Built-in part for wall-mounted one-way mixer.
- UP-Einbaukörper für Einweg-Einhebelmischer.
- Partie encastrée pour mitigeur à une sortie.
- Parte emprotrable mezclador monomando una salida.
- Встроенная часть одноходового смесителя.
- 壁装式单出水口龙头的预埋件。

FINITURA • FINISHING • FARBE • COULEUR • CODICE • CODE • CODE • CODE • ACABADO • ОТДЕЛКА • 表面处理 CODIGO • КОД • 代码

| | |
|-----------|-----------------|
| Raw Brass | 05.2430.4.05.00 |
|-----------|-----------------|

87.9107.9

NEW

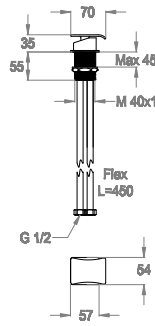

- Deviatore incasso al piano a due uscite.
- Deck-mounted built-in 2-way diverter.
- UP-Zweiwege-Umstellventil.
- Inverseur encastré sur plan à deux sorties.
- Inversor empotrable de encimera de dos salidas.
- Встроенный в стол двухходовой переключатель.
- 台装嵌入式两路分流阀。



G 1/2 (F) G 1/2 (F) 0590540

| FINITURA • FINISHING • FARBE • COULEUR • ACABADO • ОТДЕЛКА • 表面处理 | CODICE • CODE • CODE • CODE • CODIGO • КОД • 代码 |
|---|---|
| Chrome | 87.9107.9.10.00 |
| Gold Glam | 87.9107.9.18.00 |
| White Mood | 87.9107.9.20.01 |
| Black Coffee | 87.9107.9.30.07 |
| Gold Colour | 87.9107.9.30.13 |

87.9108.9

NEW

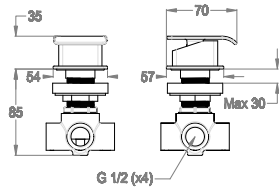

- Deviatore incasso al piano a tre uscite.
- Deck-mounted built-in 3-way diverter.
- UP-Dreiwege-Umstellventil.
- Inverseur encastré sur plan à trois sorties.
- Inversor empotrable de encimera de tres salidas.
- Встроенный в стол трехходовой переключатель.
- 台装嵌入式三路分流阀。



G 1/2 (F) G 1/2 (F) 0590566

| FINITURA • FINISHING • FARBE • COULEUR • ACABADO • ОТДЕЛКА • 表面处理 | CODICE • CODE • CODE • CODE • CODIGO • КОД • 代码 |
|---|---|
| Chrome | 87.9108.9.10.00 |
| White Mood | 87.9108.9.20.01 |

87.9417.8

NEW



- Parte esterna deviatore incasso a parete.
- External part for wall-mounted built-in diverter.
- Fertigmontageset zu UP-Umstellventil.
- Partie extérieure pour inverseur encastré.
- Parte externa inversor empotrable mural.
- Наружная часть встроенного в стену переключателя.
- 壁嵌式分流阀的外露部件。



Articoli complementari necessari
Necessary complementary items
Notwendige komplementäre Artikel
Articles complémentaires nécessaires
Artículos complementarios necesarios
Необходимые дополнительные предметы
必须的配套产品

05.2459.0



page 729

- Parte incasso deviatore due uscite.
- Built-in part for two-way diverter valve.
- UP-Einbaukörper zu Zweiwege-Umstellventil
- Partie encastrée pour inverseur à deux sorties.
- Parte empotrable para inversor dos salidas.
- Встроенная часть двухходового переключателя.
- 两路分流阀的预埋件。

05.2459.1



page 730

- Parte incasso deviatore tre uscite.
- Built-in part for three-way diverter valve.
- UP-Einbaukörper zu Dreiwege-Umstellventil
- Partie encastrée pour inverseur à trois sorties.
- Parte empotrable para inversor tres salidas.
- Встроенная часть трехходового переключателя.
- 三路分流阀的预埋件。

| FINITURA • FINISHING • FARBE • COULEUR • ACABADO • ОТДЕЛКА • 表面处理 | CODICE • CODE • CODE • CODE • CODIGO • КОД • 代码 |
|---|---|
| Chrome | 87.9417.8.10.00 |
| Gold Glam | 87.9417.8.18.00 |
| White Mood | 87.9417.8.20.01 |

| FINITURA • FINISHING • FARBE • COULEUR • ACABADO • ОТДЕЛКА • 表面处理 | CODICE • CODE • CODE • CODE • CODIGO • КОД • 代码 |
|---|---|
| Raw Brass | 05.2459.0.05.00 |

| FINITURA • FINISHING • FARBE • COULEUR • ACABADO • ОТДЕЛКА • 表面处理 | CODICE • CODE • CODE • CODE • CODIGO • КОД • 代码 |
|---|---|
| Raw Brass | 05.2459.1.05.00 |

87.4241.2

! Nicht für deutschsprachige Märkte

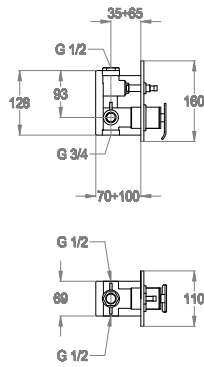

- Miscelatore vasca doccia incasso a parete.
- Built-in shower and bath mixer.
- UP-Wannenfüll- und Brausearmatur.
- Mitigeur bain/douche encastré.
- Mezclador monomando baño/ducha empotrable.
- Смеситель, встроенный в стену, для ванной и душа.
- 壁嵌式淋浴和浴缸龙头。

| FINITURA • FINISHING • FARBE • COULEUR • ACABADO • ОТДЕЛКА • 表面处理 | CODICE • CODE • CODE • CODE • CODIGO • КОД • 代码 |
|---|---|
| Chrome | 87.4241.2.10.00 |
| Gold Glam | 87.4241.2.18.00 |
| White Mood | 87.4241.2.20.01 |
| Black Coffee | 87.4241.2.30.07 |
| Gold Colour | 87.4241.2.30.13 |



87.4278.2

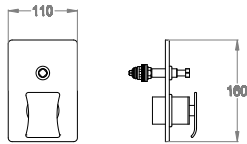

- Parte esterna miscelatore vasca doccia incasso a parete.
- External part for wall-mounted built-in shower and bath mixer.
- Fertigmontageset zu UP-Wannenfüll- und Brausearmatur.
- Partie extérieure pour mitigeur bain/douche encastré.
- Parte externa para mezclador monomando baño/ducha empotrable.
- Наружная часть встроенного в стену смесителя для ванной и душа.
- 壁嵌式淋浴和浴缸龙头的外露部件。

| FINITURA • FINISHING • FARBE • COULEUR • ACABADO • ОТДЕЛКА • 表面处理 | CODICE • CODE • CODE • CODE • CODIGO • КОД • 代码 |
|---|---|
| Chrome | 87.4278.2.10.00 |
| Gold Glam | 87.4278.2.18.00 |
| White Mood | 87.4278.2.20.01 |
| Black Coffee | 87.4278.2.30.07 |
| Gold Colour | 87.4278.2.30.13 |



Articoli complementari necessari
 Necessary complementary items
 Notwendige komplementäre Artikel
 Articles complémentaires nécessaires
 Artículos complementarios necesarios
 Необходимые дополнительные предметы
 必须的配套产品

05.2421.4



page 727

- Parte incasso miscelatore a due uscite.
- Built-in part for two-way mixer.
- UP-Einbaukörper für Zweiwege-Einhebelmischer.
- Partie encastrée pour mitigeur à deux sorties.
- Parte empotrable para mezclador monomando dos salidas.
- Встроенная часть двухходового смесителя.
- 双出水口龙头的预埋件。

| FINITURA • FINISHING • FARBE • COULEUR • ACABADO • ОТДЕЛКА • 表面处理 | CODICE • CODE • CODE • CODE • CODIGO • КОД • 代码 |
|---|---|
| Raw Brass | 05.2421.4.05.00 |

➔ 87.4341.2

⚠ Nicht für deutschsprachige Märkte

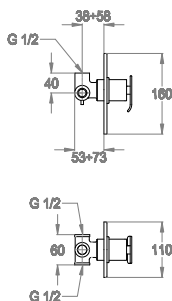

- Miscelatore doccia incasso a parete.
- Built-in shower mixer.
- UP-Brausearmatur.
- Mitigeur de douche encastré.
- Monomando ducha empotrable.
- Встроенный в стену смеситель для душа.
- 壁嵌式淋浴龙头。

| FINITURA • FINISHING • FARBE • COULEUR • ACABADO • ОТДЕЛКА • 表面处理 | CODICE • CODE • CODE • CODE • CODIGO • КОД • 代码 |
|---|---|
| Chrome | 87.4341.2.10.00 |
| Gold Glam | 87.4341.2.18.00 |
| White Mood | 87.4341.2.20.01 |
| Black Coffee | 87.4341.2.30.07 |
| Gold Colour | 87.4341.2.30.13 |



➔ 87.4378.2

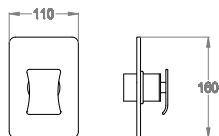

- Parte esterna miscelatore doccia incasso a parete.
- External part for built-in shower mixer.
- Fertigmontageset zu UP-Brausearmatur.
- Partie extérieure pour mitigeur de douche encastré.
- Parte externa para monomando empotrable.
- Наружная часть встроенного в стену смесителя для душа.
- 壁嵌式淋浴龙头的外露部件。

| FINITURA • FINISHING • FARBE • COULEUR • ACABADO • ОТДЕЛКА • 表面处理 | CODICE • CODE • CODE • CODE • CODIGO • КОД • 代码 |
|---|---|
| Chrome | 87.4378.2.10.00 |
| Gold Glam | 87.4378.2.18.00 |
| White Mood | 87.4378.2.20.01 |
| Black Coffee | 87.4378.2.30.07 |
| Gold Colour | 87.4378.2.30.13 |



Articoli complementari necessari
Necessary complementary items
Notwendige komplementäre Artikel
Articles complémentaires nécessaires
Artículos complementarios necesarios
Необходимые дополнительные предметы
必须的配套产品

05.2430.4

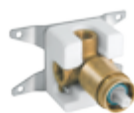

page 725

- Parte incasso miscelatore a parete ad una uscita.
- Built-in part for wall-mounted one-way mixer.
- UP-Einbaukörper für Einweg-Einhebelmischer.
- Partie encastrée pour mitigeur à une sortie.
- Parte empotrable mezclador monomando una salida.
- Встроенная часть одноходового смесителя.
- 壁装式单出水口龙头的预埋件。

| FINITURA • FINISHING • FARBE • COULEUR • ACABADO • ОТДЕЛКА • 表面处理 | CODICE • CODE • CODE • CODE • CODIGO • КОД • 代码 |
|---|---|
| Raw Brass | 05.2430.4.05.00 |

87.4539.2



- Parte esterna rubinetto incasso a parete.
- External part for wall-mounted built-in straight stop.
- Fertigmontageset zu Unterputzventil.
- Partie extérieure pour robinet encastré.
- Parte externa para llave de paso.
- Наружная часть встроенного в стену крана.
- 壁嵌式直旋塞阀的外露部件。

| FINITURA • FINISHING • FARBE • COULEUR • ACABADO • ОТДЕЛКА • 表面处理 | CODICE • CODE • CODE • CODE • CODIGO • КОД • 代码 |
|---|---|
| Chrome | 87.4539.2.10.00 |
| Gold Glam | 87.4539.2.18.00 |
| White Mood | 87.4539.2.20.01 |



Articoli complementari necessari
Necessary complementary items
Notwendige komplementäre Artikel
Articles complémentaires nécessaires
Artículos complementarios necesarios
Необходимые дополнительные предметы
必须的配套产品

05.2451.4



page 728

- Parte incasso rubinetto destro a parete.
- Built-in part for wall-mounted straight stop, right.
- UP-Einbaukörper zu Unterputzventil, rechts.
- Partie encastrée pour robinet mural, droit.
- Parte empotrable para llave de paso, derecha.
- Встроенная часть настенного правого крана.
- 壁装式右直旋塞阀的预埋件。

| FINITURA • FINISHING • FARBE • COULEUR • ACABADO • ОТДЕЛКА • 表面处理 | CODICE • CODE • CODE • CODE • CODIGO • КОД • 代码 |
|---|---|
| Raw Brass | 05.2451.4.05.00 |

05.2451.6



page 728

- Parte incasso rubinetto sinistro a parete.
- Built-in part for wall-mounted straight stop, left.
- UP-Einbaukörper zu Unterputzventil, links.
- Partie encastrée pour robinet mural, gauche.
- Parte empotrable para llave de paso, izquierda.
- Встроенная часть настенного левого крана.
- 壁装式左直旋塞阀的预埋件。

| FINITURA • FINISHING • FARBE • COULEUR • ACABADO • ОТДЕЛКА • 表面处理 | CODICE • CODE • CODE • CODE • CODIGO • КОД • 代码 |
|---|---|
| Raw Brass | 05.2451.6.05.00 |

87.3360.2

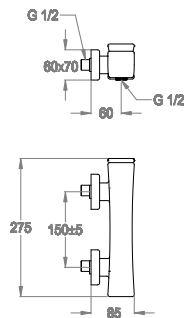

- Miscelatore doccia esterno a parete con attacco flex.
- Wall-mounted shower mixer with flex hose connection.
- AP-Brause-Einhebelmischer mit Verbindung für Brauseschlauch.
- Mitigeur de douche mural avec raccord flexible.
- Mezclador monomando ducha mural con conexión flex.
- Наружный настенный смеситель для душа с гибким креплением.
- 带软管接头的壁装式淋浴龙头。

| FINITURA • FINISHING • FARBE • COULEUR • ACABADO • ОТДЕЛКА • 表面处理 | CODICE • CODE • CODE • CODE • CODIGO • КОД • 代码 |
|---|---|
| Chrome | 87.3360.2.10.00 |
| Gold Glam | 87.3360.2.18.00 |
| White Mood | 87.3360.2.20.01 |



G 1/2 0590536

87.3361.2

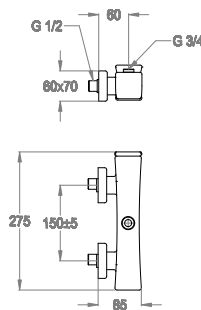

- Miscelatore doccia esterno a parete con attacco per colonna doccia esterna.
- Wall-mounted shower mixer with external shower bar connection.
- AP-Brause-Einhebelmischer mit Verbindung zur Duschkombination.
- Mitigeur de douche mural avec raccord pour colonne de douche externe.
- Mezclador monomando ducha mural con conexión para columna de ducha externa.
- Наружный настенный смеситель для душа с креплением к наружной колонне для душа.
- 带淋浴杆接头的壁装式淋浴龙头。

| FINITURA • FINISHING • FARBE • COULEUR • ACABADO • ОТДЕЛКА • 表面处理 | CODICE • CODE • CODE • CODE • CODIGO • КОД • 代码 |
|---|---|
| Chrome | 87.3361.2.10.00 |
| White Mood | 87.3361.2.20.01 |



G 3/4 0590536

➤ 87.3392.2

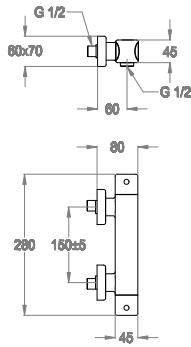

- Miscelatore doccia esterno termostatico a parete con attacco flex.
- Wall-mounted thermostatic shower mixer with flex hose connection.
- AP-Brausethermostat mit Verbindung für Brauseschlauch.
- Mitigeur de douche thermostatique mural avec raccord flexible.
- Mezclador termostático ducha mural con conexión flex.
- Термостатический наружный настенный смеситель для душа с гибким креплением.
- 带软管接头的壁装式恒温淋浴龙头。



| FINITURA • FINISHING • FARBE • COULEUR • ACABADO • ОТДЕЛКА • 表面处理 | CODICE • CODE • CODE • CODE • CODIGO • КОД • 代码 |
|---|---|
| Chrome | 87.3392.2.10.00 |
| White Mood | 87.3392.2.20.01 |

➤ 87.3395.2

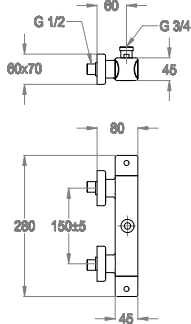

- Miscelatore doccia esterno termostatico a parete con attacco per colonna doccia esterna.
- Wall-mounted thermostatic shower mixer with external shower bar connection.
- AP-Brausethermostat mit Verbindung zur Duschkombination.
- Mitigeur de douche thermostatique mural avec raccord pour colonne de douche externe.
- Mezclador termostático ducha mural con conexión para columna de ducha externa.
- Термостатический наружный настенный смеситель для душа с креплением к наружной колонне для душа.
- 带淋浴杆接头的壁装式恒温淋浴龙头。



| FINITURA • FINISHING • FARBE • COULEUR • ACABADO • ОТДЕЛКА • 表面处理 | CODICE • CODE • CODE • CODE • CODIGO • КОД • 代码 |
|---|---|
| Chrome | 87.3395.2.10.00 |
| White Mood | 87.3395.2.20.01 |

➤ 87.4234.2

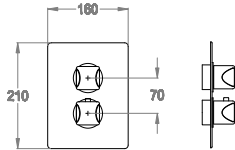

- Parte esterna miscelatore doccia incasso termostatico a parete con rubinetto d'arresto.
- External part for wall-mounted built-in thermostatic shower mixer with stop valve.
- Fertigmontageset zu UP-Brausethermostat mit Absperrventil.
- Partie extérieure pour mitigeur de douche thermostatique encastré avec robinet d'arrêt.
- Parte externa mezclador ducha empotrable termostático con llave de paso.
- Наружная часть встроенного в стену термостатического смесителя для душа с краном отключения.
- 带截止阀的壁嵌式恒温淋浴龙头的外露部件。



| FINITURA • FINISHING • FARBE • COULEUR • ACABADO • ОТДЕЛКА • 表面处理 | CODICE • CODE • CODE • CODE • CODIGO • КОД • 代码 |
|---|---|
| Chrome | 87.4234.2.10.00 |
| Gold Glam | 87.4234.2.18.00 |
| White Mood | 87.4234.2.20.01 |

Articoli complementari necessari
Necessary complementary items
Notwendige komplementäre Artikel
Articles complémentaires nécessaires
Artículos complementarios necesarios
Необходимые дополнительные предметы
必须的配套产品

05.2447.0



page 731

- Parte incasso miscelatore termostatico a parete, con rubinetto d'arresto.
- Built-in part for wall-mounted thermostatic mixer, with stop valve.
- UP-Einbaukörper zu Brausethermostat mit Absperrventil.
- Partie encastrée pour mitigeur thermostatique mural, avec robinet d'arrêt.
- Parte empotrable mezclador termostático mural, con llave de paso.
- Встроенная часть термостатического настенного смесителя, с краном отключения.
- 带截止阀的壁装式恒温淋浴龙头的预埋件。

| FINITURA • FINISHING • FARBE • COULEUR • ACABADO • ОТДЕЛКА • 表面处理 | CODICE • CODE • CODE • CODE • CODIGO • КОД • 代码 |
|---|---|
| Raw Brass | 05.2447.0.05.00 |

87.4253.2

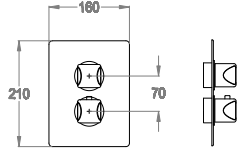

Thermo

- Parte esterna miscelatore doccia incasso termostatico a parete con rubinetto d'arresto e deviatore a due uscite.
- External part for wall-mounted built-in thermostatic shower mixer with stop valve and two-way diverter.
- Fertigmontageset zu UP-Brausethermostat mit Absperrventil und Zweiwege-Umstellventil.
- Partie extérieure pour mitigeur de douche thermostatique encastré avec robinet d'arrêt et inverseur à deux sorties.
- Parte externa mezclador ducha empotrable termostático con llave de paso y inversor de dos salidas.
- Наружная часть встроенного в стену терmostатического смесителя для душа с краном отключения и двухходовым переключателем.
- 外露部件，用于带截止阀和两路分流阀的壁嵌式恒温淋浴龙头。

| FINITURA • FINISHING • FARBE • COULEUR • ACABADO • ОТДЕЛКА • 表面处理 | CODICE • CODE • CODE • CODE • CODIGO • КОД • 代码 |
|---|---|
| Chrome | 87.4253.2.10.00 |
| Gold Glam | 87.4253.2.18.00 |
| White Mood | 87.4253.2.20.01 |

Articoli complementari necessari
Necessary complementary items
Notwendige komplementäre Artikel
Articles complémentaires nécessaires
Artículos complementarios necesarios
Необходимые дополнительные предметы
必须的配套产品

05.2447.2



page 731

- Parte incasso miscelatore termostatico a parete, con rubinetto d'arresto e deviatore a due uscite.
- Built-in part for wall-mounted thermostatic shower mixer, with stop valve and two-way diverter.
- UP-Einbaukörper zu Brausethermostat mit Absperr- und Zweiwege-Umstellventil.
- Partie encastrée pour mitigeur thermostatique mural, arrivée d'eau, avec robinet d'arrêt et inverseur à deux sorties.
- Parte empotrable mezclador termostático mural, con llave de paso y inversor de dos salidas.
- Встроенная часть терmostатического настенного смесителя, с краном отключения и двухходовым переключателем.
- 预埋件,用于带截止阀和两路分流阀的壁装式恒温淋浴龙头。

| FINITURA • FINISHING • FARBE • COULEUR • ACABADO • ОТДЕЛКА • 表面处理 | CODICE • CODE • CODE • CODE • CODIGO • КОД • 代码 |
|---|---|
| Raw Brass | 05.2447.2.05.00 |

87.4253.3

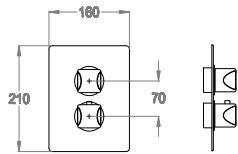

Thermo

- Parte esterna miscelatore doccia incasso termostatico a parete con rubinetto d'arresto e deviatore a tre uscite.
- External part for wall-mounted built-in thermostatic shower mixer with stop valve and three-way diverter.
- Fertigmontageset zu UP-Brausethermostat mit Absperrventil und Dreiwege-Umstellventil.
- Partie extérieure pour mitigeur de douche thermostatique encastré avec robinet d'arrêt et inverseur à trois sorties.
- Parte externa mezclador ducha empotrable termostático con llave de paso y inversor de tres salidas.
- Наружная часть встроенного в стену терmostатического смесителя для душа с краном отключения и трехходовым переключателем.
- 外露部件，用于带截止阀和三路分流阀的壁嵌式恒温淋浴龙头。

| FINITURA • FINISHING • FARBE • COULEUR • ACABADO • ОТДЕЛКА • 表面处理 | CODICE • CODE • CODE • CODE • CODIGO • КОД • 代码 |
|---|---|
| Chrome | 87.4253.3.10.00 |
| Gold Glam | 87.4253.3.18.00 |
| White Mood | 87.4253.3.20.01 |

Articoli complementari necessari
Necessary complementary items
Notwendige komplementäre Artikel
Articles complémentaires nécessaires
Artículos complementarios necesarios
Необходимые дополнительные предметы
必须的配套产品

05.2447.3



page 732

- Parte incasso miscelatore termostatico a parete, con rubinetto d'arresto e deviatore a tre uscite.
- Built-in part for wall-mounted thermostatic shower mixer, with stop valve and three-way diverter.
- UP-Einbaukörper zu Brausethermostat mit Absperr- und Dreiwege-Umstellventil.
- Partie encastrée pour mitigeur thermostatique mural, avec robinet d'arrêt et inverseur à trois sorties.
- Parte empotrable mezclador termostático mural, con llave de paso y inversor de tres salidas.
- Встроенная часть терmostатического настенного смесителя, с краном отключения и трехходовым переключателем.
- 预埋件,用于带截止阀和三路分流阀的壁装式恒温淋浴龙头。

| FINITURA • FINISHING • FARBE • COULEUR • ACABADO • ОТДЕЛКА • 表面处理 | CODICE • CODE • CODE • CODE • CODIGO • КОД • 代码 |
|---|---|
| Raw Brass | 05.2447.3.05.00 |

87.3923.2

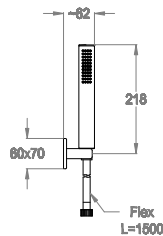

- Doccetta duplex a parete.
- Wall-mounted hand shower.
- Brausegarnitur.
- Ensemble douche.
- Ducha de mano duplex.
- Настенный душ дуплекс.
- 壁装式手持花洒。



| FINITURA • FINISHING • FARBE • COULEUR • ACABADO • ОТДЕЛКА • 表面处理 | CODICE • CODE • CODE • CODE • CÓDIGO • КОД • 代码 |
|---|---|
| Chrome | 87.3923.2.10.00 |
| Gold Glam | 87.3923.2.18.00 |
| White Mood | 87.3923.2.20.01 |

87.3972.2

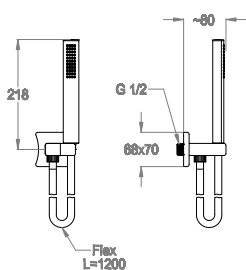

- Doccetta duplex incasso a parete con presa acqua.
- Built-in hand shower set with wall water inlet.
- Brausegarnitur zur Wandmontage mit integriertem Wasseranschluss.
- Ensemble douche encastré avec arrivée d'eau.
- Ducha de mano duplex empotrable con toma de agua.
- Настенный душ дуплекс с забором воды.
- 带墙进水的壁装式手持花洒。



| FINITURA • FINISHING • FARBE • COULEUR • ACABADO • ОТДЕЛКА • 表面处理 | CODICE • CODE • CODE • CODE • CÓDIGO • КОД • 代码 |
|---|---|
| Chrome | 87.3972.2.10.00 |
| Gold Glam | 87.3972.2.18.00 |
| White Mood | 87.3972.2.20.01 |

87.3973.2

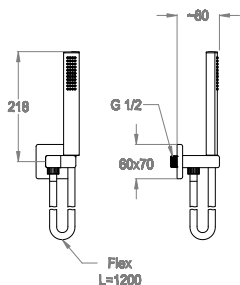

- Doccetta duplex incasso a parete con presa acqua.
- Built-in hand shower set with wall water inlet.
- Brausegarnitur zur Wandmontage mit integriertem Wasseranschluss.
- Ensemble douche encastré avec arrivée d'eau.
- Ducha de mano duplex empotrable con toma de agua.
- Настенный душ дуплекс с забором воды.
- 带墙进水的壁装式手持花洒。



| FINITURA • FINISHING • FARBE • COULEUR • ACABADO • ОТДЕЛКА • 表面处理 | CODICE • CODE • CODE • CODE • CÓDIGO • КОД • 代码 |
|---|---|
| Chrome | 87.3973.2.10.00 |
| Gold Glam | 87.3973.2.18.00 |
| White Mood | 87.3973.2.20.01 |
| Black Coffee | 87.3973.2.30.07 |
| Gold Colour | 87.3973.2.30.13 |

87.3886.0

| | |
|---|---|
| FINITURA • FINISHING • FARBE • COULEUR • ACABADO • ОТДЕЛКА • 表面处理 | CODICE • CODE • CODE • CODE • CODIGO • КОД • 代码 |
| Chrome | 87.3886.0.10.00 |
| White Mood | 87.3886.0.20.01 |

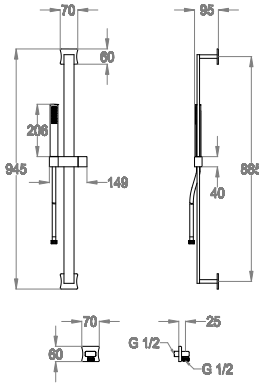

- Asta a parete con doccetta duplex, flex e presa d'acqua.
- Vertical bar with hand shower, flex and wall water inlet.
- Wandgleitstange mit Handbrause, Schlauch und Wasseranschluss.
- Barre murale avec douchette à main, flexible et arrivée d'eau.
- Barra mural con ducha de mano duplex, flex y toma de agua.
- Стенная штанга с душем дуплекс, гибкий шланг и водозабор.
- 垂直滑杆连手持花洒、软管及壁上进水口。



87.3986.0

| | |
|---|---|
| FINITURA • FINISHING • FARBE • COULEUR • ACABADO • ОТДЕЛКА • 表面处理 | CODICE • CODE • CODE • CODE • CODIGO • КОД • 代码 |
| Chrome | 87.3986.0.10.00 |
| White Mood | 87.3986.0.20.01 |

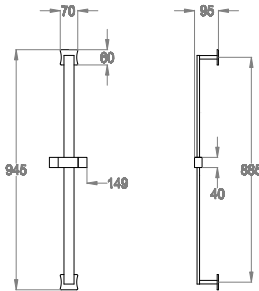

- Asta a parete.
- Vertical bar.
- Wandgleitstange.
- Barre murale.
- Barra mural.
- Стенная штанга.
- 垂直滑杆。



Playone Déco 87

➤ 05.4008.7

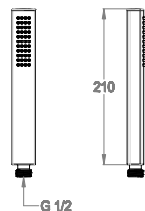

- Doccetta.
- Hand shower.
- Handbrause.
- Douchette.
- Ducha de mano.
- Душевая лейка.
- 手持花洒。

FINITURA • FINISHING • FARBE • COULEUR • ACABADO • ОТДЕЛКА • 表面处理

CODICE • CODE • CODE • CODE • CÓDIGO • КОД • 代码

| | |
|--------------|-----------------|
| Chrome | 05.4008.7.10.00 |
| Gold Glam | 05.4008.7.18.00 |
| White Mood | 05.4008.7.20.01 |
| Black Coffee | 05.4008.7.30.07 |
| Gold Colour | 05.4008.7.30.13 |



➤ 05.0001.7

NEW



- Flessibile PVC 1500 mm.
- 1500 mm PVC hose.
- PVC-Brauseschlauch 1500 mm.
- Flexible PVC 1500 mm.
- Flexible PVC 1500 mm.
- Шланг ПВХ 1500 мм.
- 1500 mm PVC软管。

FINITURA • FINISHING • FARBE • COULEUR • ACABADO • ОТДЕЛКА • 表面处理

CODICE • CODE • CODE • CODE • CÓDIGO • КОД • 代码

| | |
|----------------|-----------------|
| Natural Colour | 05.0001.7.00.00 |
|----------------|-----------------|



L=1500

➤ 05.0001.2

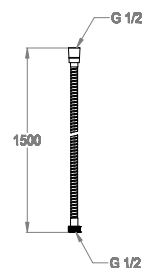

- Flessibile 1500 mm.
- 1500 mm hose.
- Brauseschlauch 1500 mm.
- Flexible 1500 mm.
- Flexible 1500 mm.
- Шланг 1500 мм.
- 1500 mm 软管。

FINITURA • FINISHING • FARBE • COULEUR • ACABADO • ОТДЕЛКА • 表面处理

CODICE • CODE • CODE • CODE • CÓDIGO • КОД • 代码

| | |
|--------------|-----------------|
| Chrome | 05.0001.2.10.00 |
| Gold Glam | 05.0001.2.18.00 |
| White Mood | 05.0001.2.20.01 |
| Black Coffee | 05.0001.2.30.07 |
| Gold Colour | 05.0001.2.30.13 |



L=1500

➤ 05.5006.0

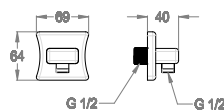

- Attacco erogazione.
- Wall water inlet.
- Wandanschlussbogen.
- Prise d'eau.
- Empalme suministro.
- Крепление излива.
- 墙进水。

FINITURA • FINISHING • FARBE • COULEUR • ACABADO • ОТДЕЛКА • 表面处理

CODICE • CODE • CODE • CODE • CÓDIGO • КОД • 代码

| | |
|------------|-----------------|
| Chrome | 05.5006.0.10.00 |
| Gold Glam | 05.5006.0.18.00 |
| White Mood | 05.5006.0.20.01 |



G 1/2

11.4821.2

FINITURA • FINISHING • FARBE • COULEUR •
ACABADO • ОТДЕЛКА • 表面处理

CODICE • CODE • CODE • CODE •
CÓDIGO • КОД • 代码

Chrome

11.4821.2.10.00

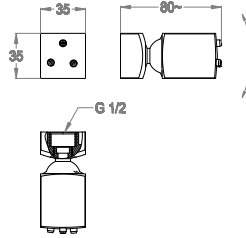

- Soffione doccia body jet laterale orientabile 35x35 mm.
- Wall-mounted adjustable body jet 35x35 mm.
- Schwenkbare Seiten-Düsen 35x35 mm.
- Jet de douche latéral orientable 35x35 mm.
- Ducha lateral orientable 35x35 mm.
- Душевая лейка body jet боковая регулируемая 35x35 мм.
- 壁装式可调身体喷头 35x35 mm。

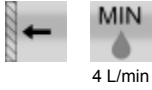

11.4822.2

FINITURA • FINISHING • FARBE • COULEUR •
ACABADO • ОТДЕЛКА • 表面处理

CODICE • CODE • CODE • CODE •
CÓDIGO • КОД • 代码

Chrome

11.4822.2.10.00

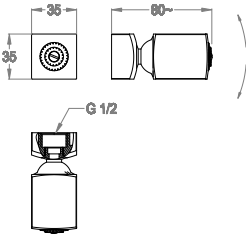

- Soffione doccia body jet laterale orientabile 35x35 mm.
- Wall-mounted adjustable body jet 35x35 mm.
- Schwenkbare Seiten-Düsen 35x35 mm.
- Jet de douche latéral orientable 35x35 mm.
- Ducha lateral orientable 35x35 mm.
- Душевая лейка body jet боковая регулируемая 35x35 мм.
- 壁装式可调身体喷头 35x35 mm。

