



I CONCI® | EXPO

Le rocce,
grazie all'eleganza
e alla straordinaria variabilità offerta,
ci concedono l'opportunità unica
di pensare infinite applicazioni ed interpretazioni.
Noi le selezioniamo, le modelliamo,
le diamo una collocazione,
ma la loro disarmante bellezza
ci induce ad esaltare ciò che più le caratterizza:
l'essere naturali.

I CONCI®





in basso: Lavabo MISSISSIPPI finitura lucida, versione semincasso in appoggio su vasca NIAGARA con finitura rigata.

Materiale Grigio Imperiale.

a destra: Zona doccia e lavamani in Grigio Imperiale con rivestimento centrale Onice Nuvolato Extra.

below: Sink MISSISSIPPI glossy finish, semi-sunken model in support on NIAGARA bathtub with striped surface Material Grigio Imperiale

right: shower area and basin in Grigio Imperiale with central cladding in Onice Nuvolato Extra.





Particolari vasca NIAGARA realizzata con doppia finitura: interno lucido, esterno rigato.

NIAGARA bathtub details made with double finish: glossy internal, external striped



Particolari lavabo MISSISSIPPI versione semincasso.
Il semincasso è realizzato su misura,
secondo le esigenze di progetto.

Details of MISSISSIPPI basin semi-sunken model.
The semi-sunken is realized
according to project requirements.





I CONCI | EXPO

Particolari zona doccia e lavamani.
Pavimento e lavabo PICO 40
in Grigio Imperiale finitura lucida,
piatto doccia ISEO e rivestimento
con finitura rigata.

Details shower area and wash basin.
Floor and sink PICO 40
in glossy Grigio Imperiale,
ISEO shower tray
and striped cladding





Mobile sospeso METAURO 120
in Pietra Brown con lavabo MISSISSIPPI
coordinato versione in appoggio.
Rivestimento in Travertino S.Caterina
Venato a poro aperto.
Pavimento posato a macchia aperta
con finitura spazzolata.

Pietra Brown outstanding
furniture METAURO 120 with
coordinated MISSISSIPPI basin
for support base.
Cladding in Travertino S.Caterina
Venato open pore effect.
Floor laid with "bookmatching" effect,
with brushed finish.

I CONCI | EXPO





I CONCI | EXPO

Particolari lavabo MISSISSIPPI
versione in appoggio,
realizzato in Pietra Brown.
Il bordo del lavabo
ha uno spessore di 2 cm.

Details MISSISSIPPI basin
support base version
in Pietra brown.
The basin's edge
has a thickness of 2 cm.



Specchio DELON realizzato con cornice in massello di pietra.
Materiale Grigio Imperiale finitura lucida.
Dimensioni 200x100 cm.

DELON mirror with frame made of solid stone.
Material glossy Grigio Imperiale.
Size 200x100 cm.



Lavabo COLORADO con mobile
versione in appoggio a terra in Travertino Oniciato.
Zona doccia con piatto doccia ISEO e cornice cristallo
realizzata in Travertino Oniciato.

COLORADO washbasin with floor-standing
version furniture in Travertino Oniciato.
Shower area with shower tray ISEO and crystal frame
made of Travertino Oniciato.





I CONCI | EXPO

Particolari zona doccia,
la cornice cristallo è rivestita in travertino
con speciali rinforzi interni.

Details of shower area,
the crystal frame is clad by Travertino
with special internal reinforcements.





Ambiente realizzato in Grigio Imperiale.
Vasca NIAGARA e piano d'appoggio
con finitura rigata, lavabo PIEGA
con finitura lucida.
Sullo sfondo, frangisole girevole
realizzato in Travertino Venato
con effetto a poro aperto.

Setting realized in Grigio Imperiale.
NIAGARA bathtub and counter top
with stripped finish.
PIEGA washbasin with glossy surface
In the background, sun-blind made
with Travertino Venato
open pore effect.



Particolare della lavorazione rigata fine realizzata su marmo Grigio Imperiale.

Detail of small striped working realized in Grigio Imperiale marble.





Immagini dal Salone del Mobile di Milano, in primo piano lavabo realizzato in Onice Nuvolato Extra, sullo sfondo a sinistra lavabo PIEGA in Grigio Imperiale, a destra vasca NILO in Samarcanda.

Images from the Salone del Mobile (Milano), in the foreground a sink made with Onice Nuvolato Extra. In the background on the left, Washbasin PIEGA in Grigio Imperiale, on the right NILO bathtub in Samarcanda







I CONCI | EXPO





Mobili sospesi con doppio lavabo COLORADO
in Grigio Imperiale con ante in pietra coordinata.
Rivestimento GRAFFITI in Giallo Solare.

Suspended furnitures with COLORADO
double sink in Grigio Imperiale with coordinated
frontal elements in stone.
Cladding GRAFFITI in Giallo Solare





Mobile lavabo COLORADO,
contenitore pensile TEVERE
con anta in pietra.
Rivestimento GRAFFITI in Giallo Solare.
Sulla sinistra separè girevole
in Grigio Imperiale Lucido.

Basin vanity unit COLORADO,
vane with shelf TEVERE
with stone door.
Cladding GRAFFITI in Giallo Solare.
On the left revolving screen
in glossy Grigio Imperiale.



I CONCI | EXPO



Particolari del nuovo piatto doccia circolare della collezione ISEO, presentato in Travertino Striato con finitura levigata. Con lo stesso materiale sono stati realizzati pavimento e rivestimento con effetto "a correre".

Detail of the new circular shower tray from the ISEO collection, seen here in Travertino Striato marble in polished finish. The use of the same marble on both floor and walls creates a continuous linear effect.





Doppio lavabo TONDO versione freestanding con base rivestita in pelle BROWN e lavabo in Travertino S.Caterina Venato a poro aperto.

Rivestimento in Travertino S.Caterina Striato con finitura bocciardata.

Double sink TONDO freestanding version with BROWN leather covered base and sink in Travertino S.Caterina Venato with open pore effect.

Cladding in Travertino S.Caterina Striato with bush-hammered finish.





Immagini dal Cersaie di Bologna,
ambiente realizzato in Grigio Imperiale
e Onice Nuvolato Extra.
In primo piano vasca NIAGARA
versione ad incasso e lavabo TONDO
con base in pelle.

Images from Cersaie Fair in Bologna,
setting realized in Grigio Imperiale
and Onice Nuvolato Extra.
In the foreground, sunken
version NIAGARA bathtub and sink TONDO
with leather covered base.

In primo piano pavimento in Grigio Imperiale e Bianco Lasa Vena Oro lucido formato cm.60x60.

Sullo sfondo ripiano in Onice Nuvolato Extra e rivestimento in Grigio Imperiale lucido.

In the foreground floor in glossy Grigio Imperiale and Bianco Lasa Vena Oro size cm.60x60.

In the background Onice Nuvolato Extra counter-top and cladding in glossy Grigio Imperiale.





Particolari del lavabo TONDO in Onice Nuvolato Extra con base rivestita in pelle BROWN.

Details of Onice Nuvolato Extra basin TONDO with BROWN leather covered base.



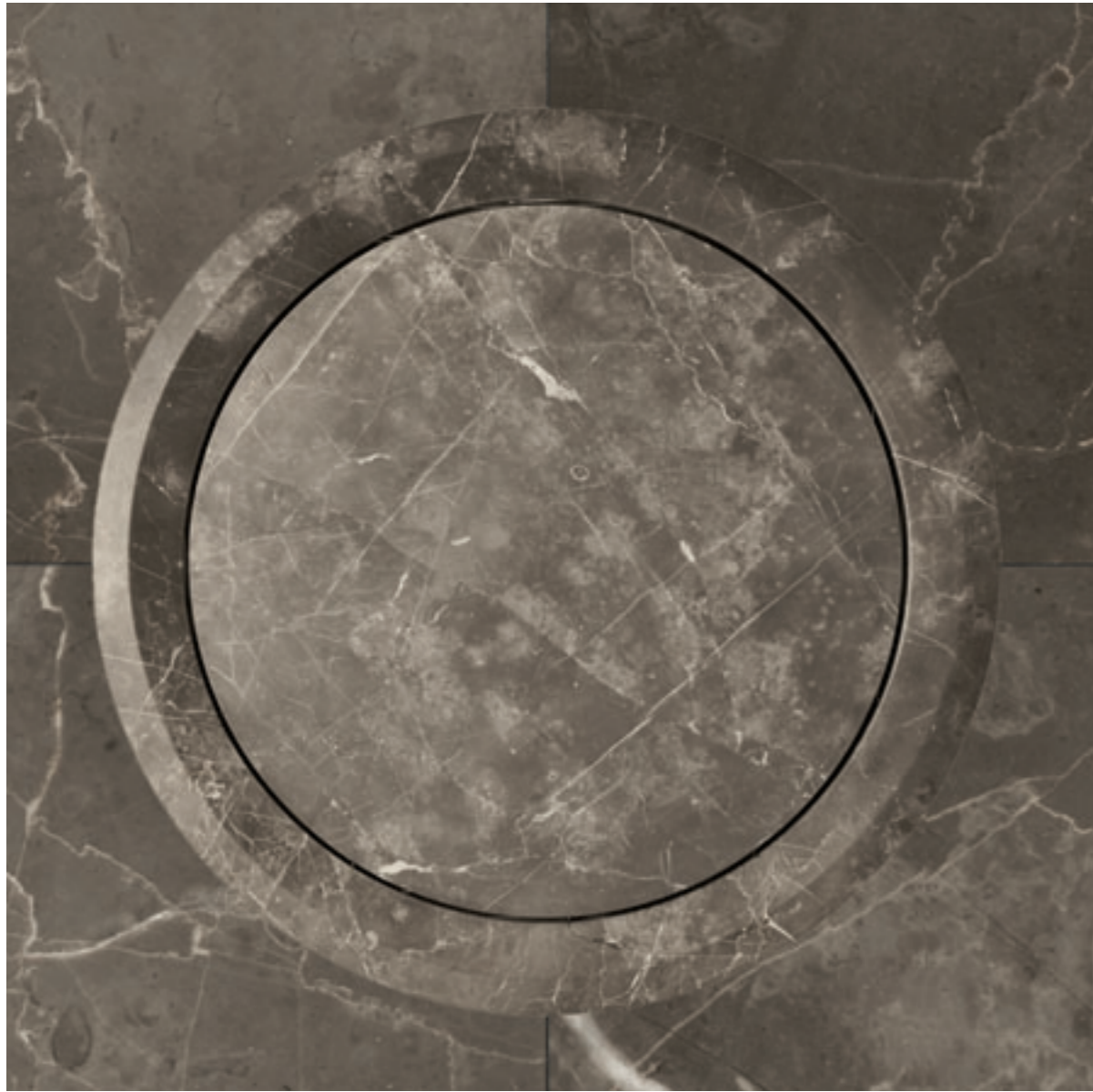

I CONCI | EXPO







Ambiente realizzato in granito Via Lattea RS.
Piano d'appoggio con finitura sabbata,
rivestimento e lavabo OTTO finitura patinata.

Setting realized in VIA LATTEA RS Granite.
Counter-top with sandblasted finish,
cladding and basin OTTO with honed finish.

I CONCI | EXPO





DISEGNI TECNICI | TECHNICAL DRAWINGS

GARDA

design: crs i conci

MOLVENO

design: crs i conci

BOLSENA

design: crs i conci

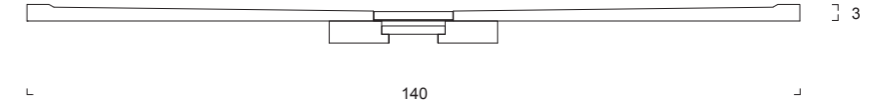
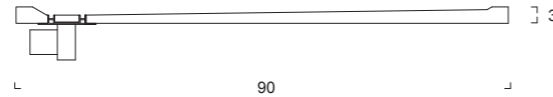
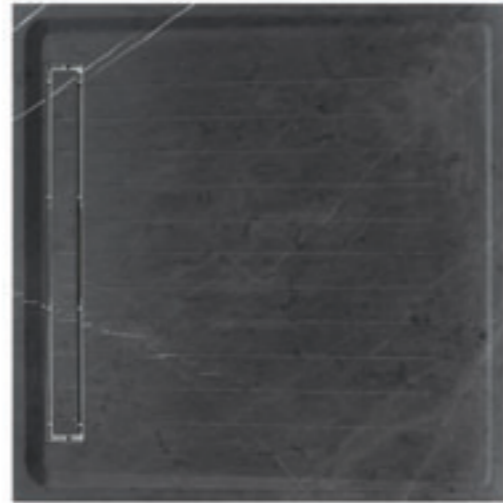
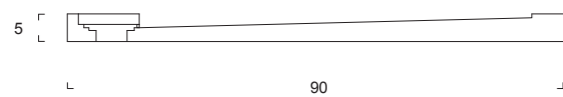

ISEO

design: bizzarri-cinti

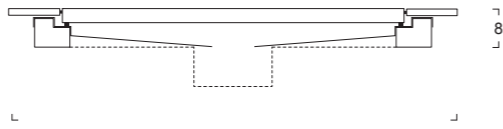
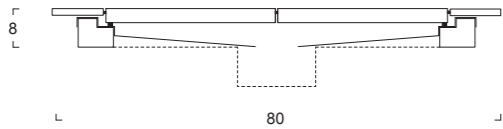
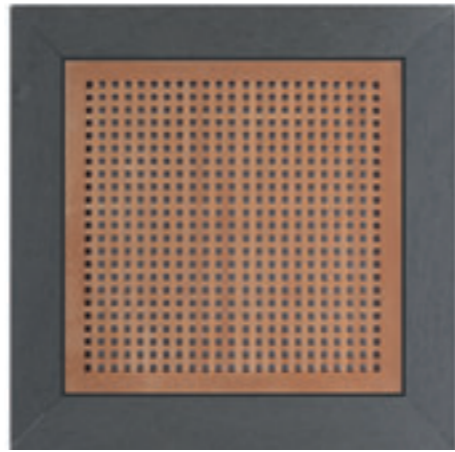

NILO

design: bizzarri-cinti

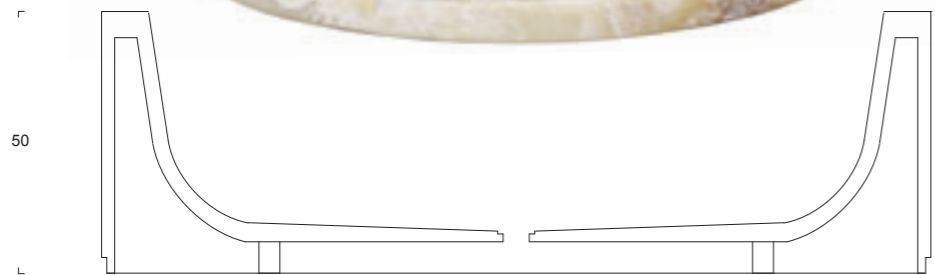

50

158

GANGE

design: bizzarri-cinti

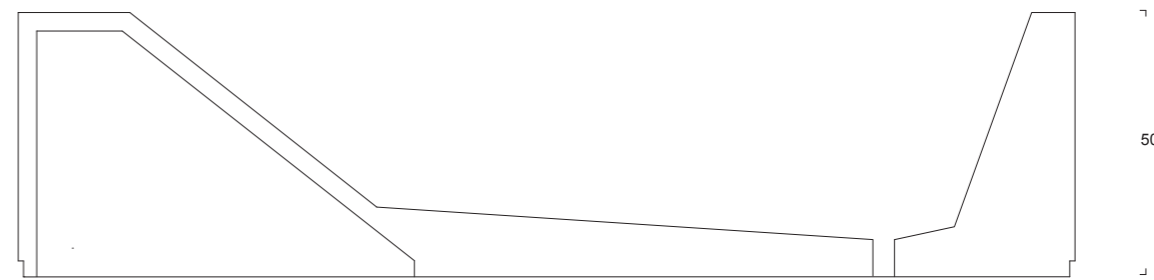

50

200

GANGE

design: bizzarri-cinti

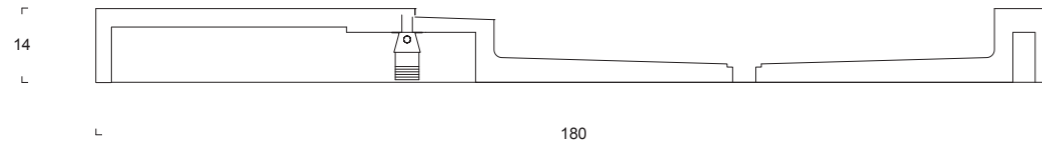
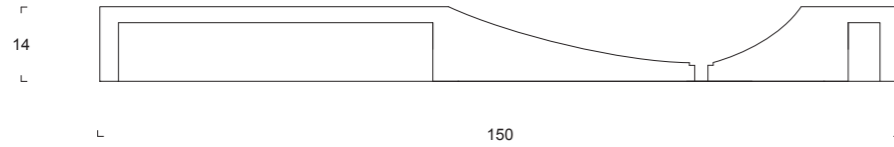

design: crs i concì

INDO

COLORADO

design: bizzarri-cinti

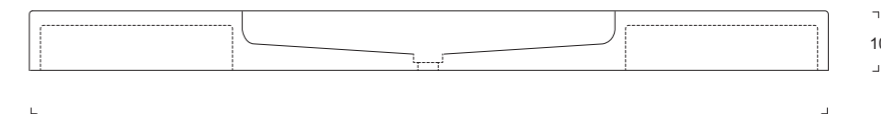
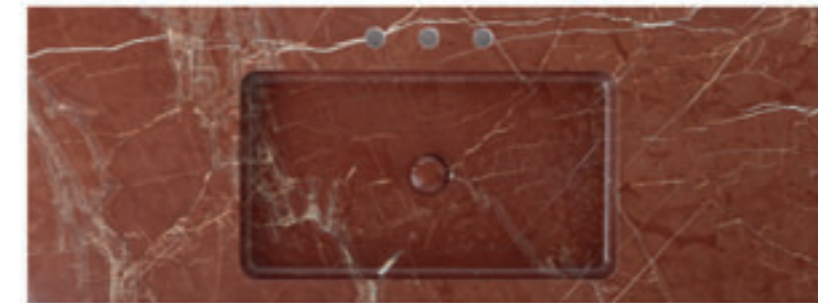
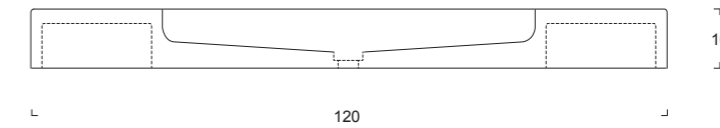

design: bizzarri-cinti

COLORADO

DANUBIO

design: bizzarri-cinti

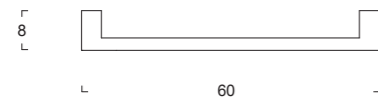
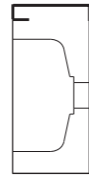
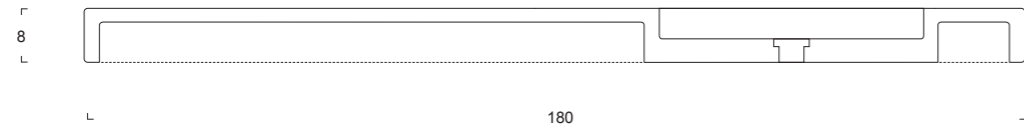
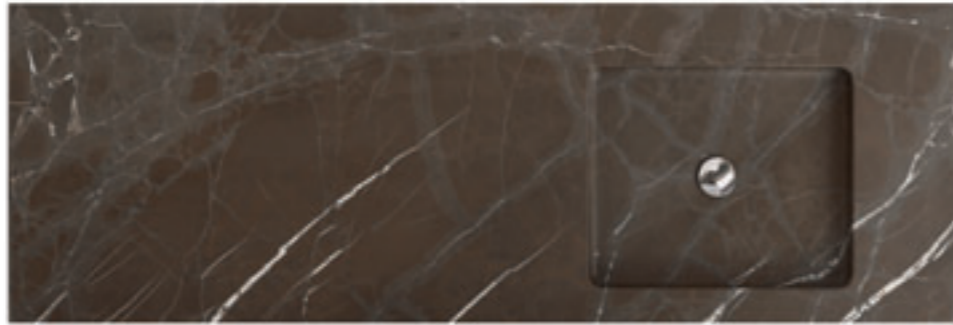

design: crs i conci

SLIDE

design: crs i conci

PICO

RETTANGOLO 2

design: bizzarri-cinti

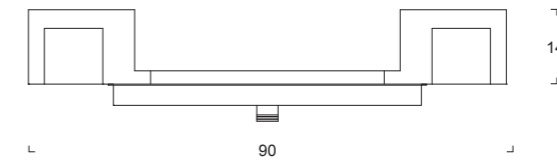
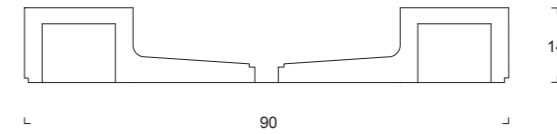

design: crs i conci

LIMBRA

MISSISSIPPI

design: crs i conci

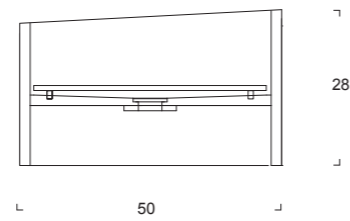
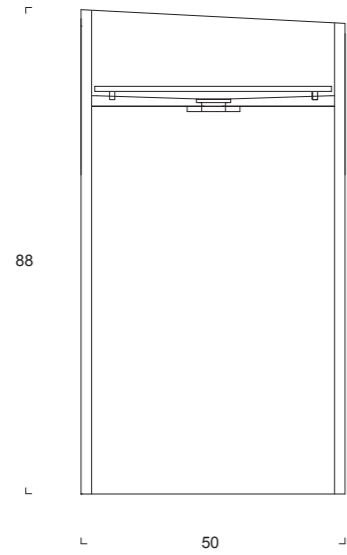

KRINY

design: bizzarri-cinti

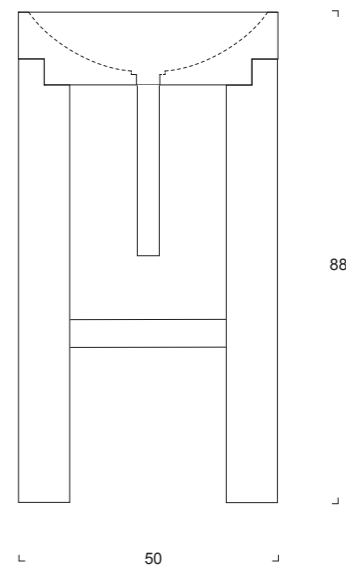
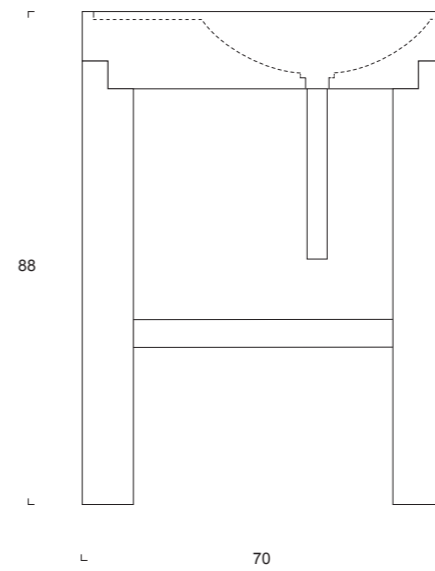

TICINO

design: bizzarri-cinti

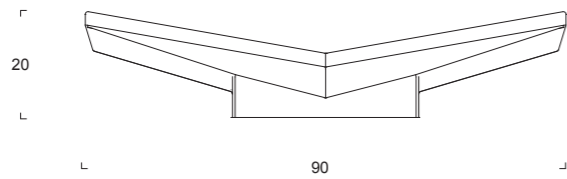
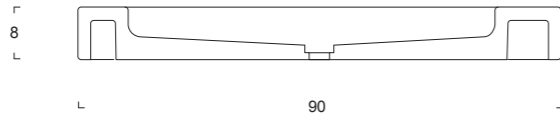

design: carlo martino

PIEGA

NILO

design: bizzarri-cinti

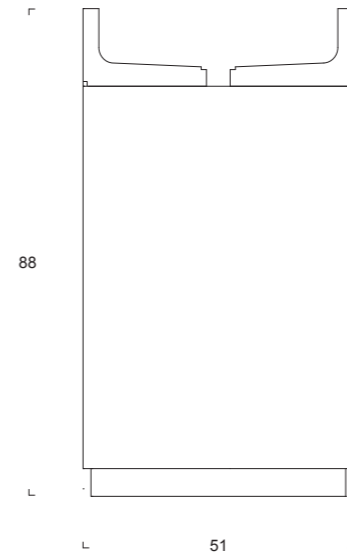

TONDO

design: crs i conci

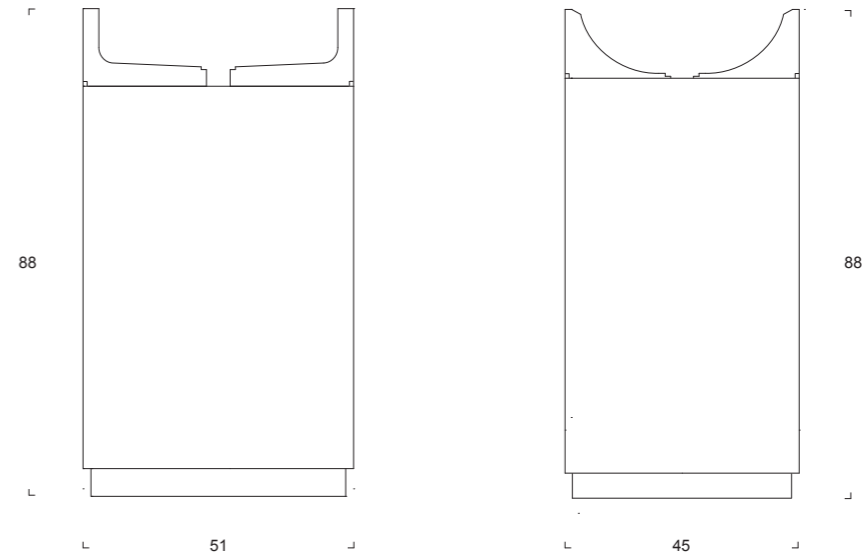

CIOTOLA

design: crs i concì

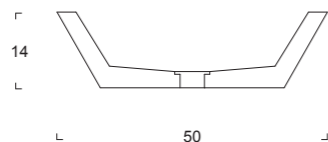
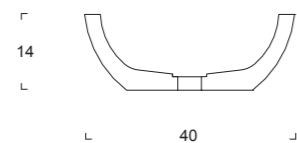

design: crs i concì

GRANDE CONCA

OVO

design: bizzarri-cinti

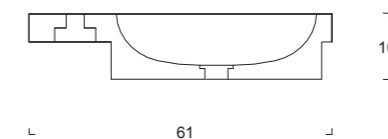
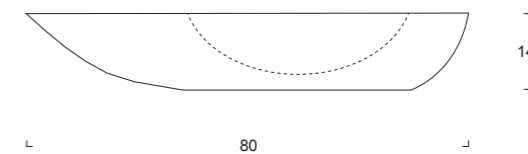

design: carlo martino

OTTO

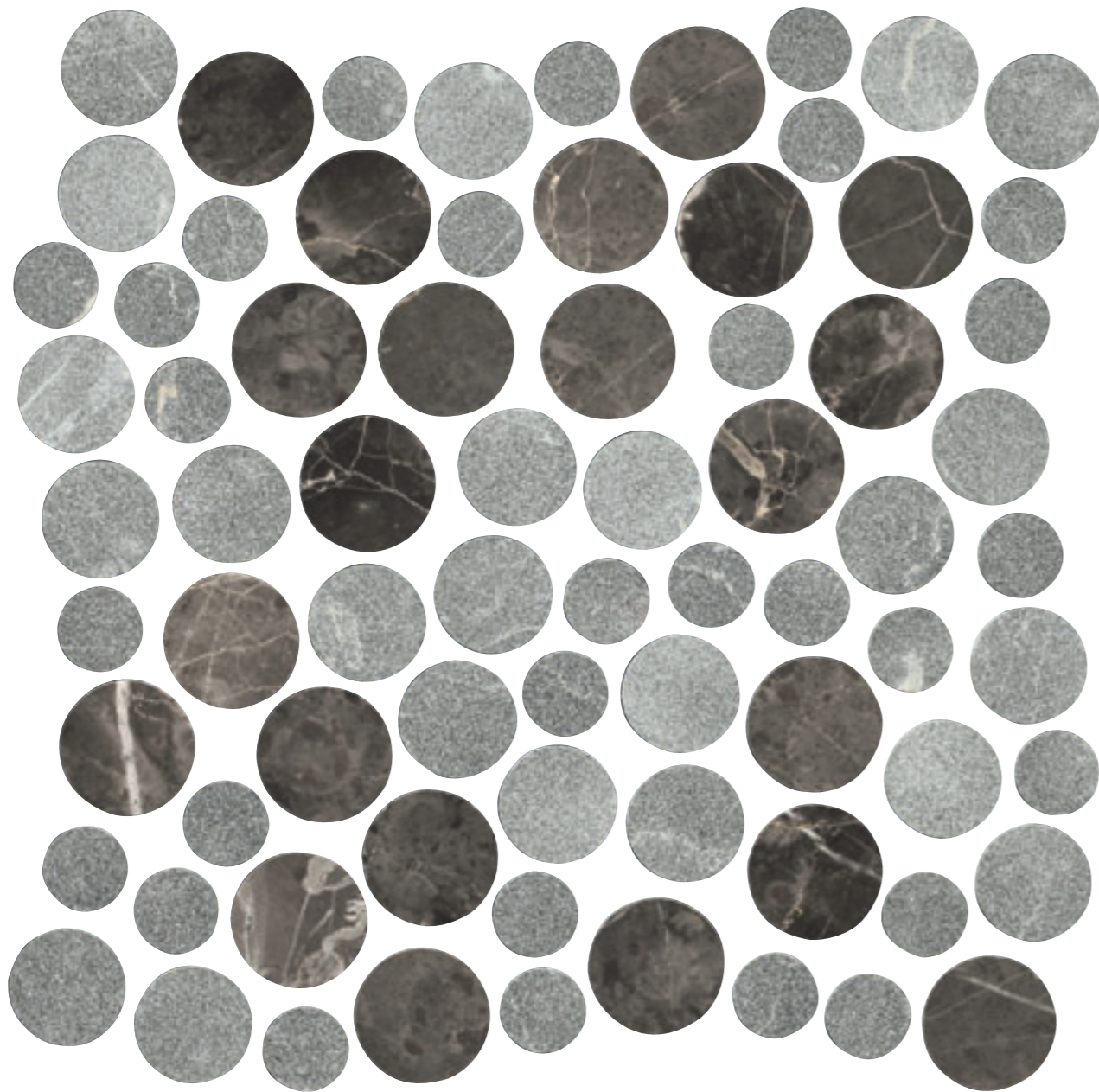

METROPOLITAN COLLECTION | GRIGIO IMPERIALE

COLORI | COLORS



MoMA COLLECTION | PIETRA GREY



AndRoMeda GOLD COLLECTION | PIETRA BROWN

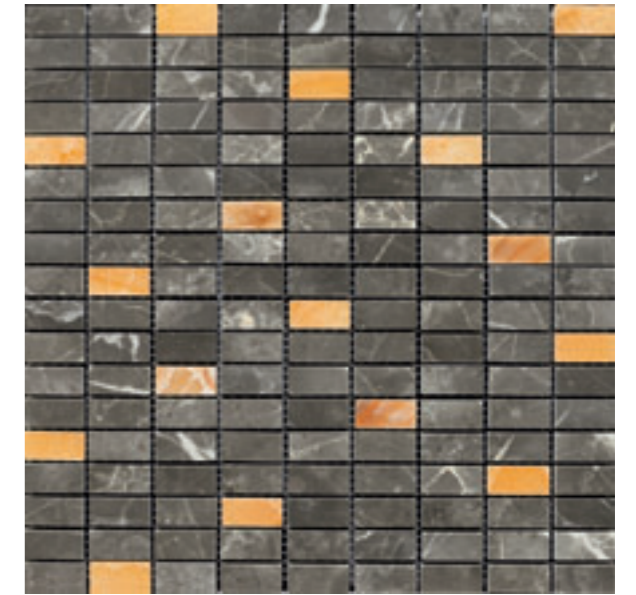

AndRoMeda ONIX COLLECTION | GRIGIO IMPERIALE

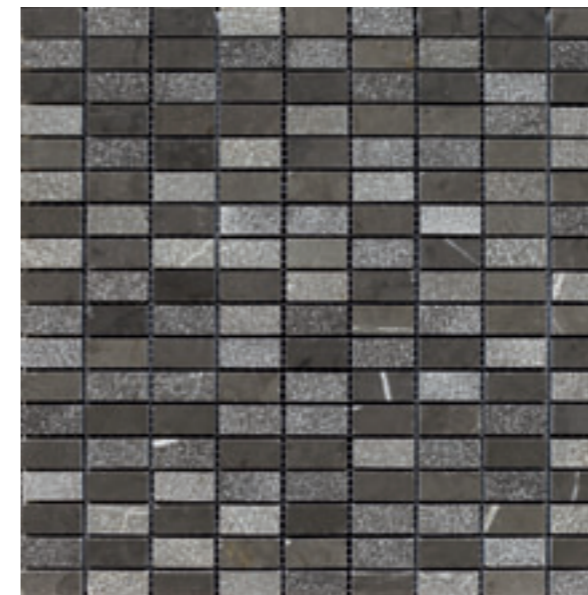

ShaKe COLLECTION | PIETRA GREY

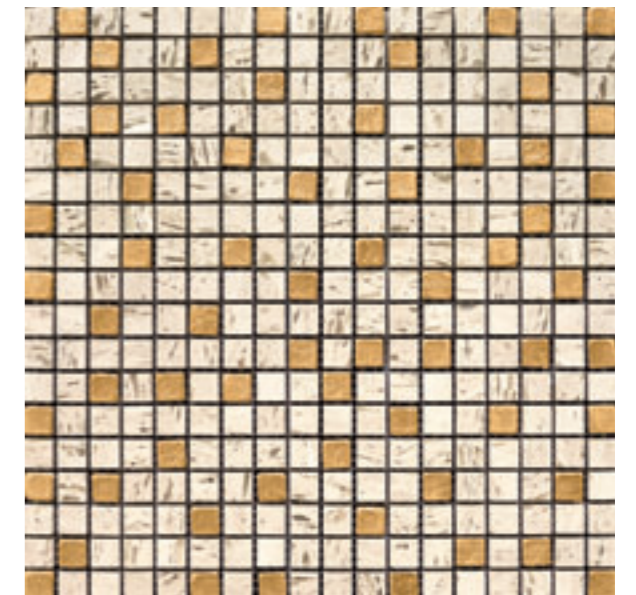

AndRoMeda GOLD COLLECTION | TRAVERTINO S. CATERINA



GRIGIO IMPERIALE

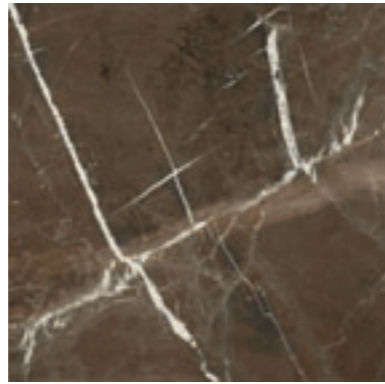

PIETRA BROWN



GIALLO SOLARE

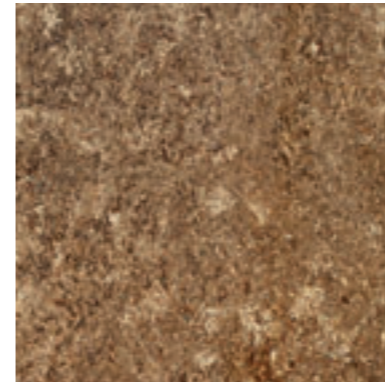

TRAVERTINO S.CATERINA ONICIATO



TRAVERTINO S.CATERINA VENATO STUCCATO



TRAVERTINO S.CATERINA VENATO
PORO APERTO / SPAZZOLATO

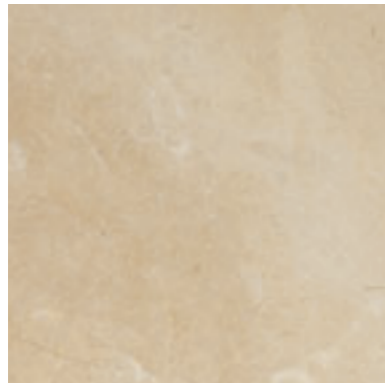

SAMARCANDA



BIANCO PERLA

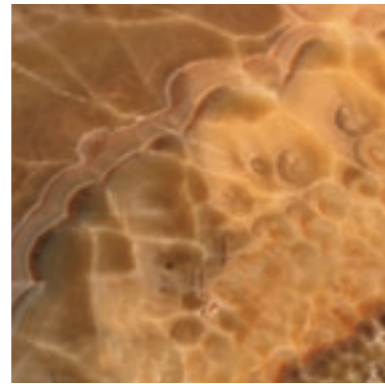

ONICE NUVOLATO EXTRA



TRAVERTINO S.CATERINA BIANCO



TRAVERTINO S.CATERINA STRIATO
AL CONTRO / LEVIGATO



TRAVERTINO S.CATERINA STRIATO
AL VERSO / SPAZZOLATO

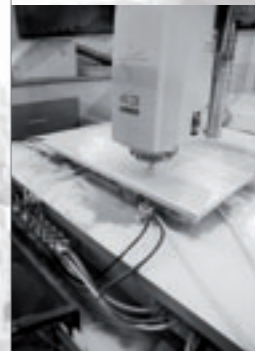

L'Azienda, fondata nel 1976 da prima come IDEAL MARMI ora come I CONCI custodisce un patrimonio di esperienze nel settore di oltre 50 anni.

L'attenzione rivolta allo sviluppo tecnologico e alla continua ricerca di prodotto hanno permesso un'evoluzione e un rinnovamento continuo nel corso degli anni.

Oggi I CONCI è una realtà con competenze in grado di soddisfare qualsiasi esigenza tecnica-progettuale proponendo materiali esclusivi, per i quali dispone di cave proprie.

The company, established in 1976 first as IDEAL MARMI, now as I CONCI preserves a unique filed resource of knowledge, made by 50 years of experience.

The attention given to technological development and continuous product research have allowed a continuous renewal over the years.

Today the company I CONCI is a reality with competences able to satisfy every technical and planning demand by offering exclusive materials, for which has its own quarries.

I CONCI®

graphic design and layout
cesare francolini

photography
cesare francolini

post production
lifeinpixel

styling & art buyer
stefano bizzarri

print
grapho5

thanks to

alberto acquati
ark&a
claudio cinti
gessi
paolo tosti (sculpture)

2011, september

I CONCI | EXPO



I Conci srl

Via Davide Albertario, 30
61032 Bellocchi di Fano (PU) Italy

Tel. +39 0721 855140
Fax +39 0721 854974

www.iconci.it
info@iconci.it