

20/
18

CATALOGO GENERALE
GENERAL CATALOGUE

LEA
CERAMICHE

INDEX / ABC

A/ ABSOLUTE
SLIMTECH
62

B/ BASALTINA STONE PROJECT
272

BASALTINA STONE PROJECT
SLIMTECH
96

BIO LUMBER
310

BIO PLANK
326

BIO RECOVER
302

BIO TIMBER
318

C/ CITY
330

CLIFFSTONE
260

D/ DISTRICT
196

DREAMING
288

G/ GOCCIA
334

GOUACHE.10 AND LIBECCIO
SLIMTECH
76

L/ LINES AND WAVES
SLIMTECH
154

LINK
342

M/ MAKÒ
220

MAUK
SLIMTECH
170

METROPOLIS
210

N/ NAIVE
SLIMTECH
146

NEST
SLIMTECH
166

NEXTONE
232

R/ RE-EVOLUTION
SLIMTECH
68

S/ SHADE AND STREETS
SLIMTECH
82

STONECLAY
226

SYSTEM L2
346

T/ TAKE CARE AND PAD
SLIMTECH
46

TECNOQUARTZ
280

TIMELESS MARBLE AND FILIGRANE
SLIMTECH
106

TRAME
184

TYPE 32
SLIMTECH
134

W/ WATERFALL
248

WATERFALL
SLIMTECH
88

WOOD-STOCK
SLIMTECH
124

INDICE

index / index / Inhalt

AZIENDA
4

PROTECT
40

SLIMTECH
42

GRES AND MORE
180

TECHNICAL INFO
352

LEGENDA CODICI
PRODOTTO / IMBALLI
381

indice analitico /

	COLLEZIONE PRODUCT	PAGINA PAGE	PROTECT	DESIGN BY
SLIMTECH	ABSOLUTE	62	(P)	
	BASALTINA STONE PROJECT	96		
	GOUACHE.10 AND LIBECCIO	76		LIBECCIO Diego Grandi
	LINES AND WAVES	154		Patrick Norguet
	MAUK	170		Diego Grandi
	NAIVE	146		Patrick Norguet
	NEST	166		HOK Product Design
	RE-EVOLUTION	68		
	SHADE AND STREETS	82		STREETS Diego Grandi
	TAKE CARE AND PAD	46	(P)	PAD Patrick Norguet
	TIMELESS MARBLE AND FILIGRANE	106	(P)	FILIGRANE Philippe Nigro
	TYPE 32	134		Diego Grandi
	WATERFALL	88	(P)	
	WOOD-STOCK	124	(P)	
GRES AND MORE	BASALTINA STONE PROJECT	272		
	BIO LUMBER	310	(P)	
	BIO PLANK	326	(P)	
	BIO RECOVER	302	(P)	
	BIO TIMBER	318	(P)	
	CITY	330		Diego Grandi
	CLIFFSTONE	260	(P)	
	DISTRICT	196	(P)	
	DREAMING	288		
	GOCCIA / MONOPOROSA	334		Kravitz Design Inc.
	MAKÒ	220		
	METROPOLIS	210	(P)	
	NEXTONE	232	(P)	
	STONECLAY / HOME	226		
	TECNOQUARTZ	280		
	TRAME	184	(P)	
	WATERFALL	248	(P)	
	LINK / PERCORSI TATTILI	342		
	SYSTEM L2 / 20 MM	346		



When Creativity meets Performance

Misurarsi costantemente in modo critico rinnova l'entusiasmo del fare, per questo tecnologia e innovazione sono alla base del nostro lavoro di ogni giorno per ottenere prodotti dallo stile senza tempo creati dalla contaminazione tra materia, colore, forme e geometrie. Lea Ceramiche è la perfetta sintesi di design visionario e performance tecnologica.

Constant critical self assessments renews the enthusiasm for doing, for this reason technology and innovation are the basis of our everyday work, achieving products with timeless style created from the mix of materials, colours, shapes and geometries. Lea Ceramiche is the perfect synthesis of visionary design and technological performance.

Se mesurer constamment de manière critique rénove l'enthousiasme d'accomplir, c'est pourquoi la technologie et l'innovation sont à la base de notre travail de chaque jour afin d'obtenir des produits au style intemporel créés par la contamination entre matière, couleur, formes et géométries. Lea Ceramiche est la synthèse parfaite du design visionnaire et des performances technologiques.

Sich ständig neuen Herausforderungen zu stellen, erneuert die Begeisterung des Tuns, denn diese Technologie und Innovation sind die Basis unserer täglichen Arbeit, um zeitlose Stilprodukte zu schaffen, die durch die Kombination von Materialien, Farben, Formen und Geometrien entstehen. Lea Ceramiche ist die perfekte Synthese aus visionärem Design und technologischer Leistung.

when creativity meets performance

Creativity

visionary design

Lea Ceramiche è partner della creatività ovunque nel mondo per ogni tipo di progetto architettonico che ricerchi distinzione attraverso uno stile unico e riconoscibile.

Lea Ceramiche is the partner of creativity all over in the world for any type of architectural project that seeks distinction through a unique and recognizable style.

Lea Ceramiche est le partenaire de la créativité partout dans le monde pour chaque type de projet architectonique qui recherche distinction à travers un style unique et reconnaissable.

Lea Ceramiche ist weltweit ein Partner für Kreativität und jede Art von architektonischem Projekt, welches sich durch einen einzigartigen und wiedererkennbaren Stil hervorheben möchte.



when creativity meets performance



Performance

industrial expertise for technical perfection

Dal concept di design allo sviluppo produttivo delle collezioni, la ricerca della perfezione in Lea Ceramiche si esprime nel segno della massima competenza tecnica, di una forza industriale di primaria eccellenza e di una continua capacità di innovazione e sviluppo.

From the design concept to the productive development of the collections, the search for perfection at Lea Ceramiche is expressed in the form of the highest technical competence, an industrial strength of primary excellence and a continuous capacity for innovation and development.

Du concept de design au développement productif des collections, la recherche de la perfection chez Lea Ceramiche s'exprime sous le signe de la plus haute compétence technique, d'une force industrielle d'excellence et d'une capacité innovative et de développement constante.

Vom Konzept des Designs bis zur produktiven Entwicklung der Kollektionen: Die Suche nach Perfektion äußert sich bei Lea Ceramiche durch höchste technische Kompetenz, industrielle Stärke primärer Exzellenz und kontinuierliche Innovation und Weiterentwicklung.

Essere visionari significa collaborare con i protagonisti del design internazionale per coglierne le esigenze, interpretarle al meglio e restituire nuova ispirazione.

Being visionary means working with leading figures in international design to understand their needs, interpret them in the best possible manner, and provide them with new inspiration.

Être visionnaires veut dire collaborer avec les grands noms du design international pour intégrer leurs exigences, les interpréter au mieux et apporter une nouvelle inspiration.

Ein Visionär zu sein bedeutet mit den Protagonisten des internationalen Designs zusammenzuarbeiten, um die Bedürfnisse zu erkennen, sie aufs Beste zu interpretieren und neue Inspiration wiederzugeben.

Inspiring Designers



inspiring designers

Philippe Nigro



Il designer francese, divide la sua attività fra il paese natale e l'Italia. L'unione delle due rispettive culture è motivo di indagine e sperimentazione e dà carattere progettuale e di ispirazione al suo lavoro, che si modula in scale differenti nel rapporto con aziende diverse. Il lavoro di Philippe Nigro è caratterizzato dalla connessione tra ricerca sperimentale e analisi pragmatica del "savoir-faire" dei committenti con cui lavora. Nella collaborazione con Lea Ceramiche, il designer francese firma la collezione Filigrane: la texture geometrica che si sovrappone a quella naturale, offre una doppia lettura, da semplice imitazione la ceramica si trasforma in materiale "neutro".

The French designer divides his work between his native country France and Italy. The union of these two respective cultures is reason for research and experimentation and imparts design and inspiration to his work, which is modulated on diverse levels when relating with different companies. Philippe Nigro's work is characterized by the connection between experimental research and the pragmatic analysis of the "savoir-faire" of his clients. In his collaboration with Lea Ceramiche, he has created the Filigrane collection: this geometric texture overlaps natural ones, which can be read in two ways: from a simple imitation, ceramic tiles become "neutral" material.

Le designer français partage son activité entre son pays natal et l'Italie. Le choc de ces deux cultures est une opportunité unique, permettant au designer d'expérimenter et de mener des recherches, pour donner à ses projets du caractère, une direction, et de les doter de cette capacité de s'adapter à différentes destinations d'usage. Le travail de Philippe Nigro est caractérisé par la connexion entre le domaine expérimental et l'analyse pragmatique du savoir-faire des maîtres d'ouvrage avec qui il travaille. Lors de sa collaboration avec Lea Ceramiche, le designer français a laissé sa touche personnelle en signant la collection Filigrane : la surface naturelle arbore des formes géométriques qui reproduisent la texture de la céramique pour se transformer en matériau « neutre ».

Der französische Designer teilt sein Geschäft zwischen seiner Heimat und Italien. Die Vereinigung der beiden jeweiligen Kulturen ist eine Frage der Erforschung und des Experimentierens und verleiht seiner Arbeit Design und Inspiration, die sich in verschiedenen Skalen in der Beziehung zu verschiedenen Unternehmen moduliert. Die Arbeit von Philippe Nigro zeichnet sich durch die Verbindung zwischen experimenteller Forschung und pragmatischer Analyse des "Savoir-faire" der Auftraggeber aus, mit denen er arbeitet. In Zusammenarbeit mit Lea Ceramiche signiert der französische Designer die Kollektion Filigrane: Die geometrische Textur, die sich mit der natürlichen überlappt, bietet eine doppelte Lesbarkeit; aus der einfacher Imitation der Keramik wird ein "neutrales" Material.

È attraverso il tratto che Patrick Norguet si avvicina al design e agli oggetti. Per il designer francese, il design è, in primo luogo, la storia di un incontro: ciò che gli interessa di più è lo scambio con i produttori, la scoperta delle loro esperienze, lo slancio di un intento creativo affinato dai vincoli della tecnica, la sfida economica e le aspettative di un cliente che lui spera, anche se discretamente, di sedurre per sempre. Il tratto contraddistingue e percorre anche tutte le collezioni che il designer francese firma per Lea Ceramiche: Lines, Waves, Naive e Pad evocano una rete di segni grafici che sulle grandi lastre ceramiche determinano prodotti con un'estetica delicata ma dinamica.

It is through lines that Patrick Norguet approaches design and objects. Interior design for this French designer is first and foremost the story of an encounter. What interests him most is an exchange with the manufacturers, discovering their experiences, this momentum of a creative intent refined by the constraints of technology, the economic challenge, and the expectations of a client that he hopes, even if discreetly, to captivate forever. The line is a distinguishing feature and it is also found throughout all the collections that Norguet has created for Lea Ceramiche: Lines, Waves, Naive, and Pad evoke a network of graphic streaks that, on large ceramic slabs, create products with a delicate but dynamic aesthetic.

Patrick Norguet aime interpréter le design et les objets à travers le pouvoir des traits. Pour lui, le design c'est avant tout un lieu de rencontre, où il est possible de communiquer avec d'autres producteurs qui grâce à leur expérience et à leur créativité ont su pallier les éventuels problèmes techniques et économiques susceptibles de miner leurs projets, pour satisfaire aux attentes des clients les plus exigeants et sophistiqués. Le trait donc, s'impose et parcourt toutes les collections de Lea Ceramiche signées par la main du designer français : Lines, Waves, Naive et Pad lancent ainsi leur filet sur de grandes dalles en céramique, pour attraper la beauté en toute délicatesse, mais avec la juste fermeté.

Patrick Norguet nähert sich Design und Objekten über lineare Muster. Für den französischen Designer ist Design vor allem die Geschichte eines Treffens: Was ihn am meisten interessiert, ist der Austausch mit den Produzenten, die Entdeckung derer Erfahrungen, die Dynamik einer kreativen Absicht, verfeinert durch die Zwänge der Technologie, die wirtschaftliche Herausforderung und die Erwartungen eines Kunden, den er hofft immer, wenn auch diskret, für sich zu gewinnen. Das lineare Merkmal unterscheidet und umfasst auch alle Kollektionen, die der französische Designer für Lea Ceramiche entworfen hat: Lines, Waves, Naive und Pad beschwören ein Netzwerk von grafischen Zeichen, die auf den großen Keramikplatten Produkte mit einer zarten, aber dynamischen Ästhetik bestimmen.

Patrick Norguet



inspiring designers

Diego Grandi



Photo credits: Helenio Barbeta

DGO_Diego Grandi Office è lo studio di progettazione che si occupa di product, interior ed exhibition design. L'attenzione all'aspetto visivo e superficiale del progetto caratterizza e determina la ricerca di Diego Grandi sul valore epidermico dei materiali e sulle possibili declinazioni e contaminazioni di genere. L'indagine sui nuovi codici dell'abitare, incentrata sull'osservazione di comportamenti e abitudini quotidiane, guida il suo atteggiamento nei confronti della superficie e sul valore profondo di progetti a due dimensioni. Questo suo orientamento diventa forma nelle collezioni disegnate per Lea Ceramiche: City, Mauk, Streets in Shade e Type 32, espressioni della visionarietà artistica del designer, in grado di tradurre il materiale ceramico in vero elemento di arredo.

DGO_Diego Grandi Office is the design studio that specializes in product, exhibition and interior design. An attention to the visual and external aspect of a project characterizes and defines the research carried out by Diego Grandi on the value of the surface of materials and on the possible variations and contaminations of the genre. Research on new living styles, focused on observing daily behaviours and habits, guides his perspective when it comes to surfaces and the profound importance of two-dimensional projects. This approach of his takes shape in the collections he designed for Lea Ceramiche: City, Mauk, Streets in Shade, and Type 32, expressions of the designer's artistic visionary quality, are capable of transforming ceramics into true furnishing accessories.

DGO_Diego Grandi Office est un studio qui se consacre à la création de produits, d'intérieurs et d'expositions de design. Pour chacun de ses projets, Diego Grandi porte une attention particulière aux détails visuels et aux surfaces, émanant d'une recherche minutieuse de la valeur épidermique pour mieux comprendre les infinies possibilités d'utilisations et de combinaisons des matériaux employés. Pour donner à ses projets cette semblance bidimensionnelle conférée par la valeur profonde de la surface, Diego s'intéresse aux nouvelles manières d'habiter, se focalisant sur les comportements et les habitudes quotidiennes des personnes. Cette étude a permis ainsi de donner forme aux collections spécialement conçues pour Lea Ceramiche : City, Mauk, Streets in Shade et Type 32, expriment le côté visionnaire et artistique du designer, et sont capables de transformer le matériau céramique en véritable élément de décoration.

DGO_Diego Grandi Office ist das Designstudio, das sich mit Produkt-, Innen- und Ausstellungsdesign beschäftigt. Die Aufmerksamkeit auf den visuellen und oberflächlichen Aspekt des Projekts charakterisiert und bestimmt die Forschung von Diego Grandi über den epidermalen Wert der Materialien und über die möglichen Variationen und Kontaminationen der Art. Die Studie über neue Lebensregeln, die sich auf das Beobachten alltäglicher Verhaltensweisen und Gewohnheiten konzentriert, bildet seinen Leitfaden gegenüber der Oberflächen und den Wert von zweidimensionalen Projekten. Diese Orientierung nimmt in den Kollektionen für Lea Ceramiche Gestalt an: City, Mauk, Streets in Shade und Type 32, Ausdrucksformen der künstlerischen Vision des Designers, der das keramische Material in ein echtes Einrichtungsstück verwandeln kann.

Musicista di successo da oltre 20 anni ma soprattutto icona di stile, Lenny Kravitz fonda nel 2003 Kravitz Design Inc. con l'obiettivo di portare la sua energia creativa al di fuori del mondo musicale. Con sede a New York nel quartiere di SoHo, lo stile Kravitz Design è poliedrico e ricercato, si esprime attraverso l'utilizzo di materiali pregiati, di texture non convenzionali per una nuova eleganza classica degli spazi. Con Goccia disegnata per Lea Ceramiche, Kravitz offre una personale e contemporanea interpretazione del decoro tridimensionale: le piccole sculture ceramiche creano molteplici composizioni in cui ogni singolo elemento diventa parte di un tutt'uno.

Over 20 years as a successful musician but, above all, as an icon of style, Lenny Kravitz founded Kravitz Design Inc. in 2003 with the objective of bringing his creative energy out of the world of music. Based in SoHo in New York, Kravitz Design style is multifaceted and sophisticated, expressed through the use of fine materials and unconventional textures for spaces with a new classic elegance. With Goccia, designed for Lea Ceramiche, Kravitz gives us a personal and contemporary interpretation of three-dimensional decor: small ceramic sculptures create multiple compositions where every single element becomes part of a whole.

Lenny Kravitz, musicien de renommée internationale depuis plus de 20 ans et véritable icône de style, a fondé en 2003 Kravitz Design Inc. afin de canaliser la source d'énergie créative et la transférer en dehors du monde de la musique. Kravitz Design, situé à New York dans le quartier de SoHo, exhibe un style recherché et aux multiples facettes. L'expression de son art se fait à travers l'utilisation de matériaux prestigieux et de textures non conventionnelles pour apporter cette touche élégante et classique dans les espaces. La collection Goccia, composée de décors tridimensionnels, que Lenny Kravitz a imaginée pour Lea Ceramiche, est un hymne moderne et intime : les petites sculptures en céramique créent de multiples compositions où tous les éléments sont en parfaite symbiose, pour ne former qu'un.

Lenny Kravitz ist seit über 20 Jahren ein erfolgreicher Musiker und vor allem eine Stilikone. 2003 gründete Lenny Kravitz die Firma Kravitz Design Inc. mit dem Ziel, seine kreative Energie aus der Musikwelt nach außen zu übertragen. Mit Sitz in New York im Bezirk SoHo ist der Stil Kravitz Design facettenreich und anspruchsvoll, was sich in der Verwendung edler Materialien und unkonventioneller Texturen für eine neue klassische Eleganz der Räume ausdrückt. Mit Goccia, das er für Lea Ceramiche entworfen hat, bietet Kravitz eine persönliche und zeitgemäße Interpretation der dreidimensionalen Dekoration: Die kleinen Keramikskulpturen bilden mehrere Kompositionen, in denen jedes einzelne Element Teil eines Ganzen wird.

Kravitz design





SPACE FOR LIFE
Marco Piva



YOU & I
Fabio Novembre



Zaha Hadid



Fabio Novembre



TWIRL
Zaha Hadid Architects



ELEPHOUNTAIN
Cibic workshop



CLEAR SWEET FRESH WATER
Antonio Citterio and Patricia Viel

Collaborations

Le capacità prestazionali e la ricercata qualità estetica hanno reso i prodotti Lea Ceramiche straordinariamente apprezzati da numerosi professionisti del panorama internazionale. Le collaborazioni avviate negli anni, hanno dato origine ad importanti realizzazioni sia in architettura che nell'interior. Alcune di queste partnership, inoltre, hanno dato forma, in qualità di exhibition, design, ad installazioni originali ed impattanti - es. *Twirl by Zaha Hadid Architects*, *Clear Sweet Fresh Water by Antonio Citterio e Patricia Viel*, *Elephountain by Cibicworkshop*, *Space for Life by Marco Piva* - veicolando, specie in questi casi, un utilizzo non convenzionale del materiale ceramico nonché la sua assoluta versatilità. Tutti i progetti realizzati finora sono il risultato del dialogo costante tra l'azienda, con il suo know how e la conoscenza esperta del materiale, e l'intelligenza dei professionisti in grado di dare forme sempre nuove a questa opportunità.

High performance levels and refined aesthetic quality, have made Lea Ceramiche products greatly acknowledged by numerous industry experts in the international panorama. These collaborations, over the years, have given rise to important achievements both in architecture and in interior design. Furthermore, with relation to exhibitions and design, several of these partnerships have given way to original and impactful installations, such as *Twirl by Zaha Hadid Architects*, *Clear Sweet Fresh Water by Antonio Citterio and Patricia Viel*, *Elephountain by Cibicworkshop*, and *Space for Life by Marco Piva*. All these convey an unconventional use for ceramic materials and the absolute versatility they offer. All the projects that have been implemented are the result of a constant dialogue between the company - with its know-how and its expert knowledge of the materials used - and the intelligence of industry experts that are able to give new life to this opportunity.

Si Lea Ceramiche est si appréciée par de nombreux professionnels du monde entier, c'est parce que ses produits font preuve d'une beauté impalpable, d'une qualité inouïe et de performances imbattables. Cette année, la société a noué de nouveaux liens, en créant des collaborations desquelles découlent d'importants projets d'architecture et d'interior design. Et certains de ces partenariats ont d'ailleurs donné naissance à des aménagements originaux et de grand impact, en matière de design et d'exposition (comme *Twirl by Zaha Hadid Architects*, *Clear Sweet Fresh Water by Antonio Citterio et Patricia Viel*, *Elephountain by Cibicworkshop*, *Space for Life by Marco Piva*) démontrant que la céramique ne connaît aucune limite d'utilisation. Tous ces projets sont le résultat d'un dialogue constant entre la société qui met à disposition ses connaissances et son savoir-faire en la matière, et les professionnels qui usent de leur intelligence et de leur maîtrise pour donner forme à cette opportunité.

Die Leistungsfähigkeit und die raffinierte ästhetische Qualität haben dazu geführt, dass die Produkte von Lea Ceramiche von zahlreichen Fachleuten der internationalen Bühne besonders geschätzt werden. Die im Laufe der Jahre begonnenen Zusammenarbeiten haben wichtige Errungenschaften sowohl in der Architektur als auch bei der Inneneinrichtung hervorgebracht. Einige dieser Partnerschaften finden sich in Form von originellen und eindrucksvollen Realisierungen für Ausstellungen und Design wieder - wie zum Beispiel *Twirl by Zaha Hadid Architects*, *Clear Sweet Fresh Water by Antonio Citterio e Patricia Viel*, *Elephountain by Cibicworkshop*, *Space for Life by Marco Piva* - wobei besonders in diesen Fällen eine eher unkonventionelle Verwendung des Keramikmaterials in ihrer absoluten Vielseitigkeit gezeigt wird. Alle bisher durchgeführten Projekte sind das Ergebnis eines ständigen Dialogs zwischen dem Unternehmen mit seinem Know-how und dem Fachwissen über das Material einerseits und der Intelligenz der Fachleute andererseits, die stets in der Lage sind, diesem Material immer neue Formen zu geben. grado di dare forme sempre nuove a questa opportunità.

Innovation for top Architecture

L'innovazione nel design, l'assoluta affidabilità delle prestazioni tecniche e la capacità di osare e guardare sempre avanti hanno reso Lea Ceramiche una protagonista indiscussa dell'architettura internazionale. Come testimoniato dalla prestigiose referenze realizzate in tutto il mondo.

Innovative design, absolute reliability of technical performance, and the capacity to dare and focus on the future have made Lea Ceramiche an undisputed key player in international architecture. As proved by the important projects supplied by the brand around the world.

L'innovation dans le design, la fiabilité absolue des performances techniques et la capacité à oser et à toujours aller de l'avant ont fait de Lea Ceramiche un protagoniste incontestable de l'architecture internationale. Comme en témoignent les importantes références dans le monde.

Die Innovation im Design, die absolute Zuverlässigkeit der technischen Leistung und die Fähigkeit zu wagen und immer nach vorne zu schauen hat Lea Ceramiche zu einem unangefochtenen Protagonisten der internationalen Architektur gemacht. Wie die Referenzen von renommierten Stellen aus der ganzen Welt beweisen.



OKKO HOTEL
Paris



CASA MILAN
Milano
Project Studio Fabio Novembre



BOSCO VERTICALE
Milano
Project Stefano Boeri Gianandrea Barreca
e Giovanni la Varra



CHANGI INTERNATIONAL AIRPORT
Singapore



Showrooms & Events

Dallo showroom di Milano al temporary Lab di Parigi, passando per gli eventi e le installazioni di impatto e suggestione in tutto il mondo, Lea Ceramiche dialoga in modo costante e vivace con il mondo del design.

From its showroom in Milan to its temporary Lab in Paris to its evocative installations and its participation in the most influential events around the world, Lea Ceramiche is engaged in a constant and animated dialogue with the world of design.

Du showroom de Milan au temporary Lab de Paris, en passant par les événements et les installations d'impact et de suggestion dans le monde entier, Lea Ceramiche dialogue de manière constante avec le monde du design.

Vom Showroom in Mailand bis zum temporären Lab in Paris, über die Events und bedeutenden und eindrucksvollen Installationen auf der ganzen Welt, Lea Ceramiche steht in einem ständigen und lebendigen Dialog mit der Welt des Designs.

Il Nostro Gruppo

OUR GROUP



LEA
CERAMICHE

COTTOD'ESTE
Nuove Superfici

 **FIORDO**

Blustyle
by COTTOD'ESTE

MARGRES
CERAMIC TILES

LOVE
CERAMIC TILES

floridatile

Bellissimo
STILE ITALIANO

PANARIAGROUP. NEL TEMPO E NEL MONDO, L'ECCELLENZA CERAMICA

THROUGHOUT TIME AND AROUND
THE WORLD, CERAMIC EXCELLENCE

Eccellere, nel mondo della ceramica di alta qualità, significa saper generare sempre prodotti a elevata componente tecnologica e impreziosirli con la massima attenzione estetica, con la cura di ogni dettaglio. Per soddisfare al meglio i gusti della fascia più elevata ed esigente del mercato, **Panariagroup** adotta da sempre la formula dell'eccellenza, unendo storica sapienza artigianale e attitudine all'avanguardia tecnologica. Con un impegno fondamentale ad agire e operare sempre con responsabilità.

Con oltre 40 anni di esperienza, **Panariagroup** è oggi una realtà internazionale con un cuore fortemente italiano, presente con 9 brand in oltre 120 paesi nel mondo grazie a una vasta e capillare rete commerciale.

To excel in the world of high quality ceramics means knowing how to continuously create highly technological products and how to enhance them through the utmost attention to aesthetics and detail. **Panariagroup** has always adhered to the highest standards of excellence, combining its history of skilful artisan craftsmanship with cutting edge technology. This approach is intrinsically linked to a fundamental commitment to always act and operate responsibly.

With over 40 years of experience, **Panariagroup** is an international company with a strong Italian soul and an extensive sales network with 9 brands in over 120 countries all over the world.

PANARIAgroup®

www.panariagroup.it



TOP SPONSOR

A hand is shown from the bottom, holding a thin, transparent sheet horizontally. The background is a soft-focus sunset over water, with warm orange and yellow tones. The text is overlaid on the right side of the image, enclosed in a white rectangular frame with a notch at the top-left and bottom-left corners.

LA RESPONSABILITÀ OLTRE LA SUPERFICIE

RESPONSIBILITY
BELOW THE SURFACES

Panariagroup realizza prodotti che incontrano la vita quotidiana di milioni di persone nel mondo, nelle case e negli ambienti pubblici; nasce da qui l'impegno fondamentale e imprescindibile a operare con responsabilità.

Da sempre all'avanguardia nel coniugare in modo sapiente bellezza, qualità e sostenibilità, Panariagroup si impegna quotidianamente per ridurre l'impatto ambientale dei suoi prodotti e stabilimenti. Per il Gruppo, inoltre, il principio dell'agire nel rispetto della sostenibilità abbraccia anche politiche e pratiche che coinvolgono e regolano gli impatti dell'organizzazione, a livello sia economico sia sociale.

Per conoscere di più sull'impegno e sulle iniziative concrete di Panariagroup, è possibile consultare il Bilancio di Sostenibilità 2016, scaricabile qui www.panariagroup.it o richiedibile via mail a sustainability@panariagroup.it

Panariagroup manufactures products that are a part of the lives of millions of people all over the world, in homes and public spaces; this is the basis for the company's fundamental and essential commitment to operating responsibly.

Always at the forefront in its knowledge of combining beauty, quality and sustainability, Panariagroup makes every effort to reduce the environmental impact of its products and plants. For the Group, the principle of sustainability also embraces policies and practices that involve and govern the impacts of the organisation, both economically and socially.

To find out more about Panariagroup's commitment and specific initiatives, you can refer to the Sustainability Report 2016, which can be downloaded here at www.panariagroup.it or requested via email at sustainability@panariagroup.it





Lastre ceramiche ultrasottili in grande formato

ULTRA-THIN CERAMIC SLABS IN LARGE SIZE

DALLES EN GRÈS CÉRAME ULTRA ÉTHER EN GRANDE FORMAT / ULTRADÜNNE KERAMISCHE PLATTEN IN GROSSER GRÖSSE

Slimtech è la superficie universale per l'architettura: sottile, resistente con l'esclusivo rinforzo di fibra di vetro, versatile e facile da utilizzare. Con l'estensione dei suoi grandi formati consente un risultato straordinario in termini di bellezza e fascino negli spazi e nelle realizzazioni architettoniche. Disponibile negli spessori 3,5 e 5,5 mm, Slimtech è leggero, planare, flessibile, semplice da utilizzare, installare e pulire: un prodotto di eccellenza, con straordinari aspetti estetici di superficie, che nasce da un processo produttivo innovativo, da materie prime di pregio, e dall'esperienza ultradecennale di Lea Ceramiche sui materiali sottili. Un materiale unico, ad elevata sostenibilità grazie al minore impiego di materie prime e ai minori impatti ambientali nel ciclo di produzione e trasporto, e dalle molteplici possibilità di applicazione: non solo pavimenti e rivestimenti ma anche mobili, complementi, cucine e piani di lavoro, pareti ventilate, rivestimenti di gallerie e grandi opere.

Slimtech is the universal surface for architecture: thin, durable with the exclusive fiberglass reinforcement, versatile and easy to use. With the extension of its large formats it gives an extraordinary result in terms of beauty and charm in spaces and architectural designs. Available in thicknesses 3.5 and 5.5 mm, Slimtech is light, planar, flexible, easy to use, install and clean: a product of excellence, with extraordinary aesthetic aspects of the surface, which is born from an innovative production process, from raw materials of high quality, and from the ultra-annual experience of Lea Ceramiche on thin materials. A unique material with high sustainability due to less use of raw materials and minor environmental impacts in the production and transportation cycle and the many possibilities of application: not only floor coverings but also furniture, complements, kitchens and worktops, ventilated walls, galleries and large works.

Slimtech est la surface universelle pour l'architecture: mince, durable avec le renfort en fibre de verre exclusif, polyvalent et facile à utiliser. Avec l'extension de ses grands formats, il donne un résultat extraordinaire en termes de beauté et de charme dans les espaces et les conceptions architecturales. Disponible en épaisseurs de 3,5 et 5,5 mm, Slimtech est léger, planaïre, flexible, facile à utiliser, à installer et à nettoyer: un produit d'excellence aux aspects esthétiques extraordinaires de la surface, né d'un processus de production innovant, à partir de matériaux qualité supérieure, et l'expérience ultradecennale de Lea Ceramiche sur les matériaux minces. Un matériau unique à haute durabilité grâce à une moindre utilisation de matières premières et des impacts environnementaux mineurs dans le cycle de production et de transport et aux nombreuses possibilités d'application: non seulement les revêtements de sol mais aussi les meubles, les compléments, les cuisines et les plans de travail, murs ventilés, galeries et grands travaux.

Slimtech ist die universelle Oberfläche für Architektur: dünn, langlebig mit der exklusiven Glasfaserverstärkung, vielseitig und einfach zu bedienen. Mit der Erweiterung seiner großen Formate gibt es ein außergewöhnliches Ergebnis in Bezug auf Schönheit und Charme in Räumen und architektonischen Entwürfen. Mit seinen Stärken von 3,5 und 5,5 mm ist Slimtech leicht, eben, flexibel, einfach zu verwenden, zu installieren und zu reinigen: ein Produkt von hervorragender Qualität mit außergewöhnlichen ästhetischen Aspekten der Oberfläche, geboren aus einem innovativen Produktionsprozess, aus Materialien Top-Qualität und die ultra-dezente Erfahrung von Lea Ceramiche auf dünnen Materialien. Ein einzigartiges Material mit hoher Nachhaltigkeit durch weniger Rohstoffeinsatz und geringen Umweltbelastungen im Produktions- und Transportkreislauf und den vielfältigen Einsatzmöglichkeiten: nicht nur Bodenbeläge, sondern auch Möbel, Ergänzungen, 4 Küchen und Arbeitsplatten, belüftete Wände, Galerien und große Werke

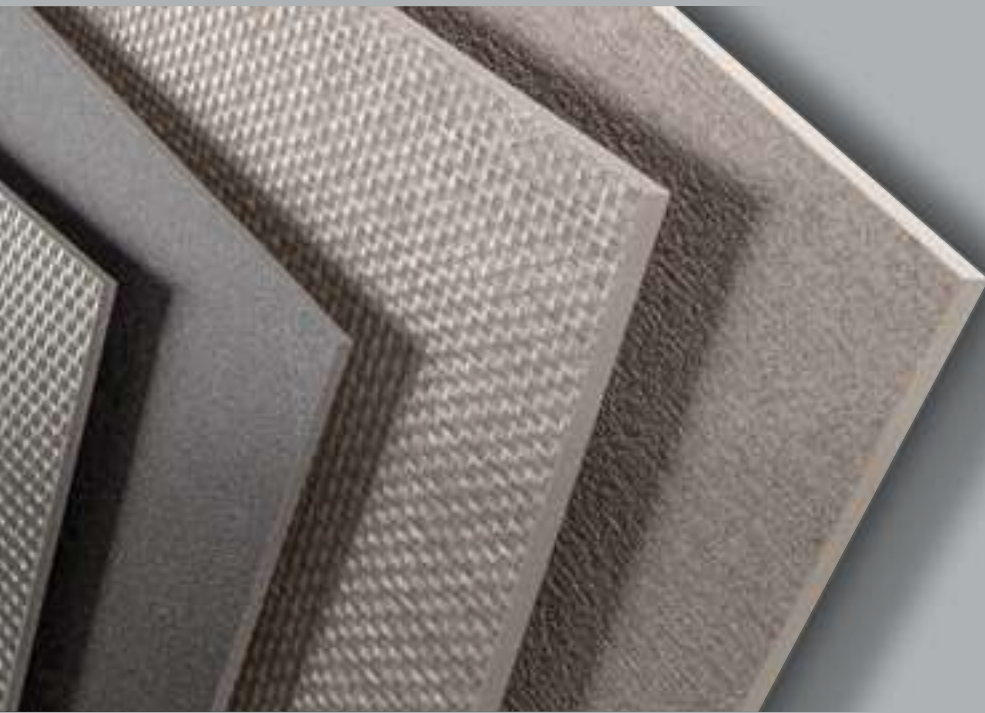

Slimtech: due spessori per infinite applicazioni

TWO THICKNESSES FOR INFINITE APPLICATIONS

DEUX ÉPAISSEURS POUR DES APPLICATIONS INFINIES / ZWEI DICKEN FÜR UNENDLICHE ANWENDUNGEN



Ideale per pavimenti e rivestimenti in ambito residenziale e commerciale leggero, sia per nuove costruzioni che per ristrutturazioni con posa in sovrapposizione a pavimenti preesistenti.

Ideal flooring and wall cladding in residential and light commercial spaces, both for new construction and renovations with tiling laid on pre-existing floors.

Idéal pour les revêtements de sol et muraux résidentiels et commerciaux légers, tant pour les nouveaux bâtiments que pour les rénovations avec des planchers qui se chevauchent aux planchers existants.

Ideal für leichte Wohn- und Gewerbeböden und Wandverkleidungen, sowohl für Neubauten als auch für Renovierungen mit überlappenden Böden zu bestehenden Fußböden.



Ideale anche per la posa in ambienti commerciali soggetti a traffico intenso, sia per nuove costruzioni che per ristrutturazioni con posa in sovrapposizione a pavimenti preesistenti.

It is also ideal for installation in commercial environments subject to heavy traffic, both for new buildings and for renovation projects with tiling laid on pre-existing floors.

Il est également idéal pour la pose dans les zones commerciales soumises à un trafic intense, à la fois pour les nouveaux bâtiments et pour les rénovations avec des planchers qui se chevauchent aux planchers existants.

Es ist auch ideal für die Verlegung in gewerblich genutzten Bereichen mit starkem Verkehrsaufkommen, sowohl für Neubauten als auch für Renovierungen mit überlappenden Etagen zu bestehenden Etagen.

Una tecnologia sostenibile che riduce l'impatto ambientale

A SUSTAINABLE TECHNOLOGY THAT REDUCES THE ENVIRONMENTAL IMPACT

UNE TECHNOLOGIE DURABLE QUI RÉDUIT L'IMPACT ENVIRONNEMENTAL
EINE NACHHALTIGE TECHNOLOGIE, DIE DIE UMWELTBELASTUNG VERRINGERT

Slimtech è frutto di un processo produttivo unico ed ecocompatibile: meno materie prime utilizzate, minor consumo di acqua ed energia e minori emissioni di CO₂

Slimtech is the result of a unique and ecologically productive process: less raw materials used, less water and energy consumption and lower CO₂ emissions.

Slimtech est le résultat d'un processus unique et écologiquement productif: moins de matières premières utilisées, moins de consommation d'eau et d'énergie et moins d'émissions de CO₂

Slimtech ist das Ergebnis eines einzigartigen und ökologisch produktiven Prozesses: weniger eingesetzte Rohstoffe, weniger Wasser- und Energieverbrauch sowie weniger CO₂ Emissionen

CARTA DI IDENTITÀ AMBIENTALE

ENVIRONMENTAL IDENTITY CARD / ENVIRONMENTAL IDENTITY CARD / ENVIRONMENTAL IDENTITY CARD

SLIMTECH 3PLUS

GRES PORCELLANATO LAMINATO RINFORZATO CON FIBRA DI VETRO
LAMINATED PORCELAIN STONEWARE REINFORCED WITH FIBREGLASS

 **3,5 mm**
SPESSORE / THICKNESS **-65%**

 **7,8 kg/m²**
PRODOTTO FINITO
FINISHED PRODUCT **-65%**

 **65 l/m²**
FABBISOGNO D'ACQUA
WATER REQUIRED **-80%**

 **190 MJ/m²**
FABBISOGNO DI ENERGIA
ENERGY REQUIRED **-30%**

 **14,1 kgCO₂/m²**
CO₂ EMESSA IN ATMOSFERA
CO₂ EMITTED IN THE ATMOSPHERE **-30%**

 **3840** ^{m²/camion}
^{m²/truck}
INCIDENZA DEL TRASPORTO
TRANSPORT FACTOR **-66%**

10 MM

GRES PORCELLANATO GENERICO
GENERIC PORCELAIN STONEWARE

10 mm
SPESSORE / THICKNESS

24 kg/m²
PRODOTTO FINITO
FINISHED PRODUCT

309 l/m²
FABBISOGNO D'ACQUA
WATER REQUIRED

275 MJ/m²
FABBISOGNO DI ENERGIA
ENERGY REQUIRED

20,6 kgCO₂/m²
CO₂ EMESSA IN ATMOSFERA
CO₂ EMITTED IN THE ATMOSPHERE

1280 ^{m²/camion}
^{m²/truck}
INCIDENZA DEL TRASPORTO
TRANSPORT FACTOR



Gres Porcellanato ad alto spessore

HIGH THICKNESS PORCELAIN STONEWARE
GRÈS CÉRAME À HAUTE ÉPAISSEUR / GLASIERTES FEINSTEINZEUG MIT HOHER STÄRKE

20mm

Le collezioni System L2 di Lea Ceramiche spessore 20mm uniscono qualità estetica ed elevate prestazioni tecniche garantendo infinite applicazioni in esterno senza preoccupazioni di rottura. Resistenti al gelo e agli sbalzi termici presentano elevate caratteristiche antiscivolo e sono facili da pulire mantenendo inalterati nel tempo materia e colore.

Lea Ceramiche's System L2 collections, 20mm thick, combine aesthetic quality and high technical performance, guaranteeing endless outdoor applications without any worries about breaking. Resistant to frost and thermal changes, they have high anti-slip characteristics and are easy to clean with the material and color remaining unaltered over time.

Les collections System L2 de Lea Ceramiche épaisseur 20 mm unissent qualité esthétique et prestations techniques élevées garantissant d'infinies applications en extérieur sans préoccupations de ruptures. Résistantes au gel et aux chocs thermiques, elles présentent des caractéristiques antidérapantes élevées et sont faciles à nettoyer tout en maintenant inaltérées dans le temps, matière et couleur.

Die Kollektionen System L2 von Lea Ceramiche mit einer Dicke von 20 mm kombinieren ästhetische Qualität und hohe technische Leistung und garantieren endlose Anwendungen im Außenbereich, ohne sich Sorgen um einen Bruch machen zu müssen. Frost- und temperaturbeständig, haben die Fliesen eine hohe Rutschfestigkeit und sind leicht zu reinigen. Material und Farbe bleiben im Laufe der Zeit unverändert.



Decors and accessories

Guardare oltre, corredando le superfici ceramiche di ricercati innesti decorativi e applicazioni raffinate, per un tratto distintivo in grado di dare sempre una personalità esclusiva ad ogni collezione Lea Ceramiche.

Looking beyond, pairing ceramic surfaces featuring refined decorative inserts with elegant applications, for a characteristic quality that gives every Lea Ceramiche collection a unique personality.

Regarder au-delà, en dotant les surfaces céramiques de greffages décoratifs recherchés et d'applications raffinées, pour un trait distinctif capable de toujours donner une personnalité exclusive à chaque collection Lea Ceramiche.

Immer einen Schritt voraus, mit Keramikoberflächen, die sich durch ausgesuchte dekorative Elemente und raffinierte Applikationen auszeichnen, für ein unverwechselbares Merkmal, die jeder Kollektion von Lea Ceramiche eine exklusive Persönlichkeit verleiht.

()



LEA

CERAMICHE

www.protect.panariagroup.it

P R () T E C T

L'esclusiva tecnologia Panariagroup per pavimenti e rivestimenti antibatterici ad altissime performance. Per un abitare sano, sicuro e protetto.

The exclusive Panariagroup technology for floor and wall coverings with the highest performance. To live healthy, safe and secure.

La technologie exclusive de Panariagroup pour les revêtements de sols et de murs antibactériens à hautes performances. Pour un habitat sain, sûr et protégé.

Die exklusive Technologie Panariagroup für antibakterielle und hochleistungsfähige Fußböden und Verkleidungen. Für ein gesundes, sicheres und geschütztes Wohnen.



AZIONE POTENTE

elimina i batteri e ne impedisce la proliferazione

ACTION PUISSANTE

élimine les bactéries et empêche leur prolifération

POWERFUL ACTION

eliminates microbes and prevents their reproduction

LEISTUNGSSTARKE WIRKUNG

eliminiert Bakterien und verhindert die Vermehrung



PROTEZIONE CONTINUA

sempre attivo, 24 ore su 24, con e senza luce solare

PROTECTION CONTINUE

toujours actif, 24 heures sur 24, avec et sans lumière du soleil

CONTINUOUS PROTECTION

always active, 24 hours a day, with and without sunlight

DAUERSCHUTZ

rund um die Uhr aktiv, mit oder ohne Sonnenlicht



EFFICACIA ETERNA

grazie alla tecnologia integrata in modo permanente nel prodotto

EFFICACITÉ ÉTERNELLE

grâce à la technologie intégrée de façon permanente dans le produit

ETERNAL EFFECTIVENESS

thanks to the technology permanently integrated into the product

DAUERHAFTE WIRKSAMKEIT

dank der permanent im Produkt integrierten Technologie



QUALITÀ GARANTITA

dalla partnership con MICROBAN®

QUALITÉ GARANTIE

du partenariat avec MICROBAN®

GUARANTEED QUALITY

by the partnership with MICROBAN®

GARANTIERTE QUALITÄT

dank der Partnership mit MICROBAN®

Slimtech è la soluzione che completa il progetto di superfici di Lea Ceramiche offrendo lastre di dimensioni oversize abbinate ad una straordinaria leggerezza. È il frutto di una tecnologia di laminazione e compattazione del gres porcellanato che rivoluziona il processo produttivo tradizionale ed ottiene così un prodotto completamente nuovo, resistente, leggero, flessibile, duttile e versatile. Slimtech soddisfa pienamente le esigenze più attuali della moderna progettazione sia per interni che per le ampie superfici esterne degli edifici contemporanei. È facile da installare e risolve, meglio di qualunque altro materiale, le problematiche del rinnovo offrendo risultati estetici eccellenti.

Slimtech is the solution that completes Lea Ceramiche's collection of products for surfaces, offering oversized slabs that are extraordinarily lightweight. It is the fruit of a lamination and compaction technology for porcelain stoneware that revolutionizes the traditional manufacturing process, thus creating a completely new, resistant, lightweight, flexible, ductile and versatile product. Slimtech fully satisfies the today's demands of modern design, both for interiors and for large exterior surfaces of contemporary buildings. It's easy to install and solves, better than any other material, renovation issues, providing excellent aesthetic results.

Slimtech est la solution innovante en matière de surfaces qui complète le projet de Lea Ceramiche en proposant des dalles XXL dotées d'une extrême légèreté. Grâce à une technologie innovante de laminage et de compactage du grès cérame, qui révolutionne ainsi le processus traditionnel de production, nous avons donné naissance à un produit entièrement innovant, résistant, léger, flexible, souple et universel. Slimtech satisfait pleinement aux exigences les plus actuelles de conception moderne d'intérieurs et de grandes surfaces d'extérieur des bâtiments contemporains. Son installation est simple et résout, mieux que tout autre matériau, les problèmes liés à la rénovation, offrant des résultats d'une excellence esthétique.

Slimtech mit ihren überdimensional großen und außergewöhnlich leichten Platten ist die Lösung, die das Projekt der Oberflächen von Lea Ceramiche ergänzt. Slimtech ist das Ergebnis einer Laminierungs- und Verdichtungstechnologie für Feinsteinzeug, die das traditionelle Herstellungsverfahren revolutioniert, mit dem Erhalt eines völlig neuen, langlebigen, leichten, biegsamen und vielseitigen Produkts. Slimtech erfüllt in vollem Umfang die Anforderungen des heutigen modernen Design für die weitreichenden Innen- und Außenflächen der zeitgenössischen Gebäude. Es ist leicht zu verlegen und löst dank des Erhalts hervorragender ästhetischer Ergebnisse besser als jedes andere Material die bei der Renovierung auftretenden Problematiken.

- 46 contemporary
TAKE CARE AND PAD design Patrick Norguet
- 62
ABSOLUTE
- 68
RE-EVOLUTION
- 76
GOUACHE.10 AND LIBECCIO design Diego Grandi
- 82
SHADE AND STREETS design Diego Grandi
- 88 stone
WATERFALL
- 96
BASALTINA STONE PROJECT
- 106 marble
TIMELESS MARBLE AND FILIGRANE design Philippe Nigro
- 124 wood
WOOD-STOCK
- 134
TYPE 32 design Diego Grandi
- 146 shapes & colors
NAIVE design Patrick Norguet
- 154
LINES AND WAVES design Patrick Norguet
- 166
NEST design HOK Product Design
- 170
MAUK design Diego Grandi
-
- 176
LEA LAB
- 178
DESTINAZIONI D'USO

GRES LAMINATO

Laminated porcelain / Grès laminé / Laminiertes Feinsteinzeug

SLIMTECH 3plus

3,5 mm

SLIMTECH 3PLUS

rinforzata con stuoia in fibra di vetro, per rivestimenti e pavimenti / reinforced with a sheet of fiberglass, for wall and floor applications / renforcé au dos par une natte en fibre de verre, pour revêtements sols et murs / mit Glasfasermatte verstärkt, Für Wand und Boden geeignet /

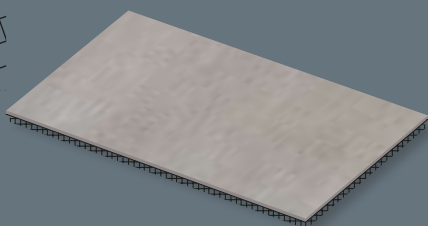

SLIMTECH 5plus

5,5 mm

SLIMTECH 5PLUS

rinforzata con stuoia in fibra di vetro, per rivestimenti e pavimenti ad alto traffico / reinforced with a sheet of fiberglass, for wall cladding and high traffic floor applications / renforcé au dos par une natte en fibre de verre, pour revêtements de sols au passage intensif et de murs / mit Glasfasermatte verstärkt, für Wand stark frequentierte Böden geeignet /

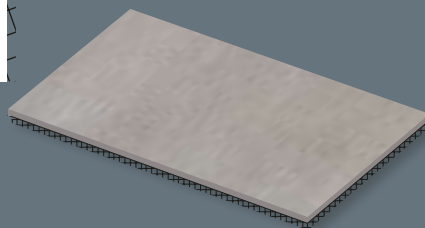

FORMATI (CM)

Sizes - Formats - Formate

	100x300	100x150	50x150	100x100	50x100	4,9x100	33x300	20x200	20x150	20x100
Absolute	•			•						
Basaltina Stone P.	•			•	•	•				
Gouache.10	•			•	•	•				
Lines	•									
Naive	•			•						
Re-evolution	•			•	•	•				
Shade	•			•	•	•				
Take Care	•	•		•						
Timeless Marble	•		•	•						
Type 32								•		
Waterfall	•			•	•					
Waves	•									
Wood-stock							•	•	•	•

UN PRODOTTO SUPERIORE

A superior product / Un produit supérieur / Ein qualitätsprodukt

GRES LAMINATO RINFORZATO CON FIBRA DI VETRO UN PRODOTTO SUPERIORE

- Più resistente
 - Più affidabile
 - Più leggero
- e adatto alle ristrutturazioni
- Più facile da lavorare
- e movimentare
- Più sicuro
 - Più flessibile

LAMINATED PORCELAIN STONEWARE REINFORCED WITH FIBREGLASS

- A SUPERIOR PRODUCT
- More resistant
 - More reliable
 - Lighter and suitable for renovations
 - Easier to work with and handle
 - Safer
 - More flexible









GRÈS CÉRAME LAMINÉ, REINFORCÉ AVEC DE LA FIBRE DE VERRE

- UN PRODUIT SUPÉRIEUR
- Plus résistant
 - Plus fiable
 - Plus léger et adapté
- aux projets de restructurations
- Plus facile à travailler et à déplacer
 - Plus sûr

MIT GLASFASERN VERSTÄRKTES FEINSTEINZEUG EIN QUALITÄTSPRODUKT

- Widerstandsfähiger
- Zuverlässiger
- Leichter und für Renovierungen geeignet
- Leichter zu bearbeiten und zu handhaben
- Sicherer
- Biegsamer



Mauk			Nest					
								
8,7x13,5x25,8	38,3	57,6	100x86,6	50x43,2	12,5x10,8	100x86,6	50x43,2	12,5x10,8
			•	•	•	•	•	•
•	•	•	•	•	•	•	•	•
			•	•	•	•	•	•
			•	•	•	•	•	•
			•	•	•	•	•	•
			•	•	•	•	•	•
			•	•	•	•	•	•
			•	•	•	•	•	•

contemporary

**TAKE CARE
and PAD**
design
Patrick Norguet



T_STEEL
100x100cm / 39"x39"



C_STEEL
100x300cm / 39"x118"

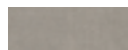

**PAD OAKLAND
SNOW**
100x300cm / 39"x118"



TAKE CARE

and PAD design Patrick Norguet

SLIMTECH | **P R () T E C T**
ANTIBATTERICO - ANTIMICROBIAL

spessore / thickness **5,5mm**

3
FORMATI LRT^{\square}
sizes / formats / Formate

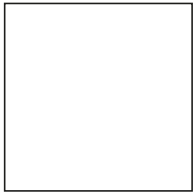

100x100cm / 39"x39"
slimtech 5plus
TAKE

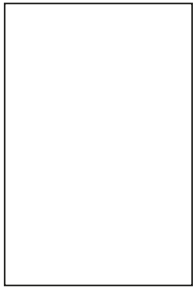

100x150cm / 39"x58"
slimtech 5plus
CARE

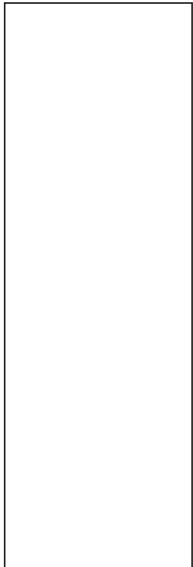

100x300cm / 39"x118"
slimtech 5plus
TAKE CARE

2
FINITURE
finishes / surfaces / Oberfläche

TAKE
CARE

5
COLORI
colors / couleurs / Farben

		T_Moon	C_Moon
T_Snow	C_Snow	T_Ground	C_Ground
T_Steel	C_Steel	T_Night	C_Night

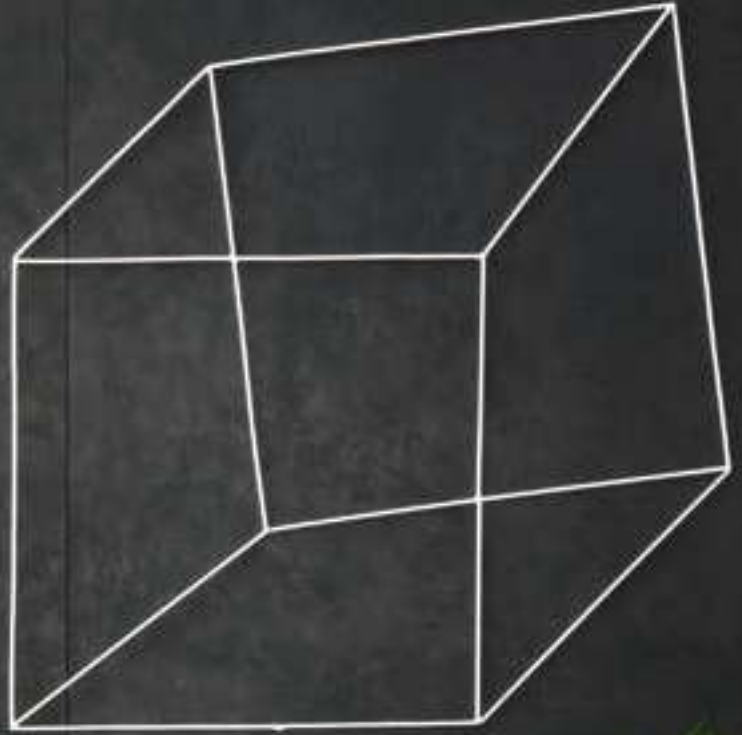

TAKE CARE

48/
49

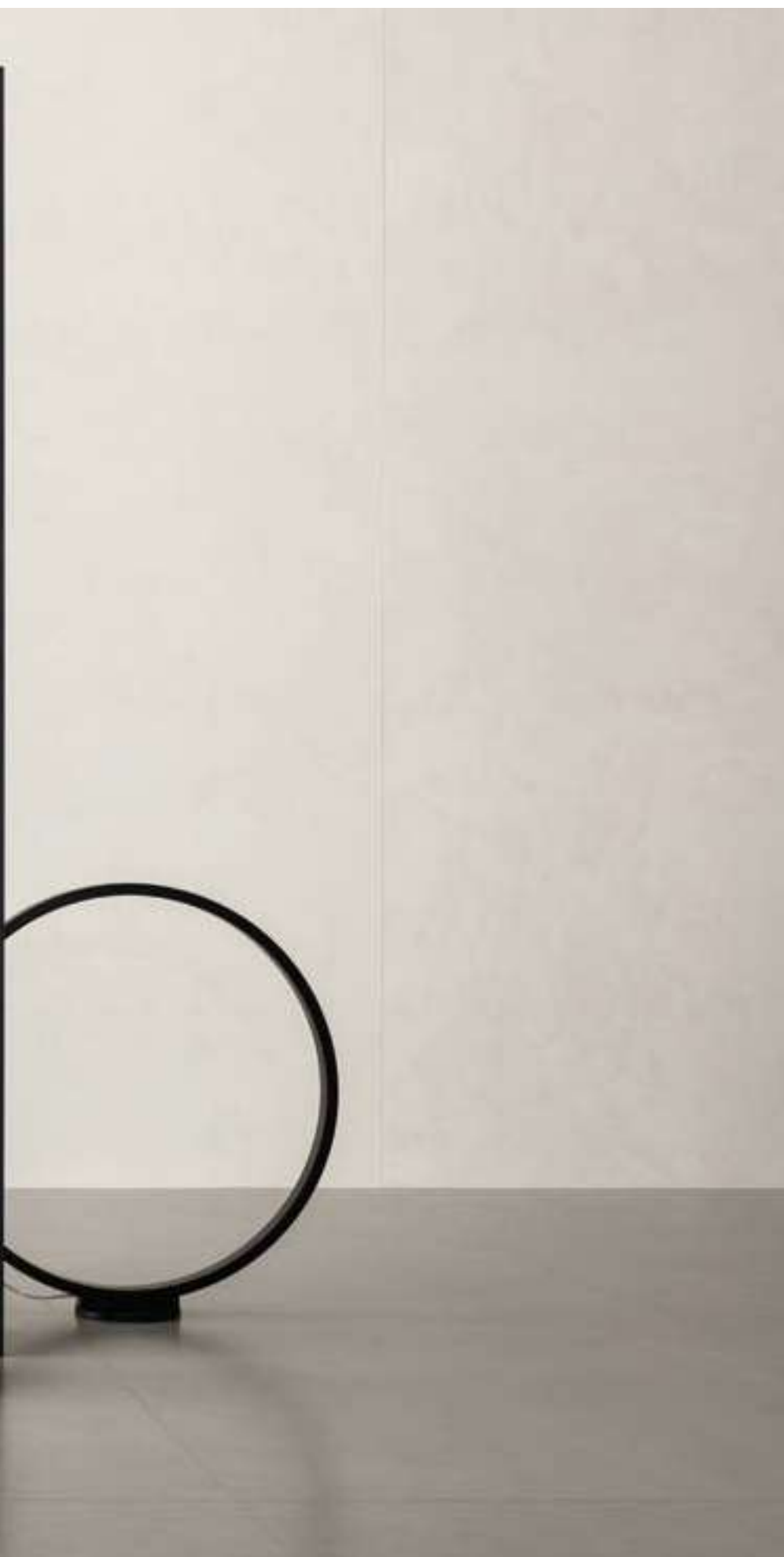

T_SNOW
100x300cm / 39"x118"

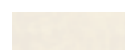

T_STEEL
100x300cm / 39"x118"



T_NIGHT
100x300cm / 39"x118"



TAKE CARE



T_GROUND
100x100cm / 39"x39"



**PAD OAKLAND
GROUND**
100x300cm / 39"x118"





contemporary



TAKE CARE

C_NIGHT

100x150 cm / 39"x58"

100x300cm / 39"x118"

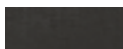

C_GROUND

100x150 cm / 39"x58"



C_STEEL

100x300cm / 39"x118"



contemporary





TAKE CARE

C_MOON
100x300cm / 39"x118"



contemporary

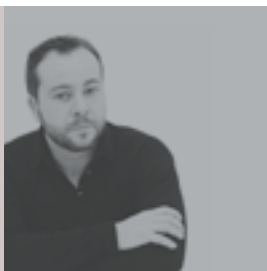

TAKE CARE PAD

design
Patrick Norguet

OAKLAND*



Oakland
snow



Oakland
moon



FORMATO

size / format / Format

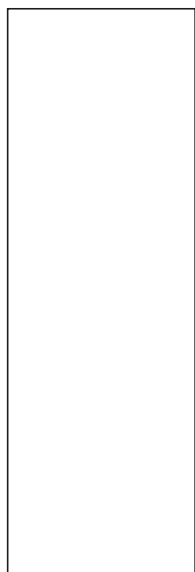

100x300cm / 39"x118"
slimtech 5plus

* Utilizzabile solo a RIVESTIMENTO / Suitable only for WALL COVERINGS
Seulement pour les REVÊTEMENTS / Nur zur VERKLEIDUNG verwendbar

LEA CERAMICHE

Oakland
steel



Oakland
ground



Oakland
night



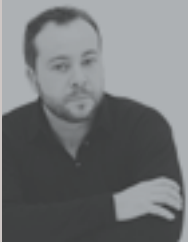

TAKE CARE PAD

design
Patrick Norguet

TAMIS*

Tamis snow A - B - C



Tamis moon A - B - C



Tamis steel A - B - C



Tamis ground A - B - C



Tamis night A - B - C

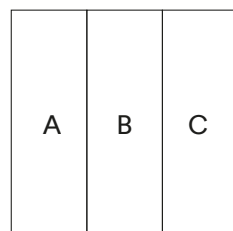

* Utilizzabile solo a RIVESTIMENTO / Suitable only for WALL COVERINGS
Seulement pour les REVÊTEMENTS / Nur zur VERKLEIDUNG verwendbar

A



B



C



TAKE CARE



TAKE CARE

GRES PORCELLANATO LAMINATO UGL

Laminated porcelain stoneware UGL / Grès laminé UGL / Laminiertes Feinsteinzeug UGL

SPESSORE

Thickness / Epaisseur / Stärke

5,5 mm → slimtech 5plus



STONALIZZAZIONE

Shading / Denuançage / Spielfarbig

ANSI A137.3

PAD - Informazioni tecniche per l'utilizzo pag. 370

Technical information for use.

Informations techniques pour l'utilisation.

Technische Zusammenarbeit.

RESISTENZA ALLO SCIVOLAMENTO

Slip resistance / Résistance au glissement

Rutschfestigkeit

DIN 51130

R9

BCR-TORTUS

$\mu > 0,40$

ANSI A326.3

DCOF ≥ 0.42

FUGA MINIMA CONSIGLIATA

Minimum suggested joint

Joint minimum conseillé

Empfohlene Fugenbreite

POSA A PARETE / Wall / Mur / Wand

1 mm (INDOOR) → slimtech 5plus

POSA A PAVIMENTO / Floor / Sol / Boden

2 mm (INDOOR) → slimtech 5plus

OUTDOOR

vedi Manuale Tecnico Slimtech

see Slimtech Technical Manual

LEGENDA CODICI PRODOTTO / IMBALLI

Legend product codes / Packing

Légende codes produits / Emballage

Legend Produktcodes / Verpackung

pag. 387/388

P R () T E C T

ANTIBATTERICO - ANTIMICROBIAL

**PAD TAMIS
MOON**

100x300cm / 39"x118"

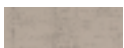

contemporary



TOTAL BLACK

100x300cm / 39"x118"

lev



TOTAL WHITE

100x100cm / 39"x39"

sat

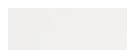

ABSOLUTE

SLIMTECH | **P R () T E C T**
ANTIBATTERICO - ANTIMICROBIAL

spessore / thickness **5,5mm**

2

FORMATI LRT^{T}

sizes / formats / Formate

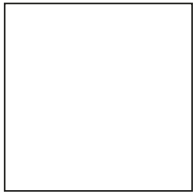

100x100cm / 39"x39"
slimtech 5plus

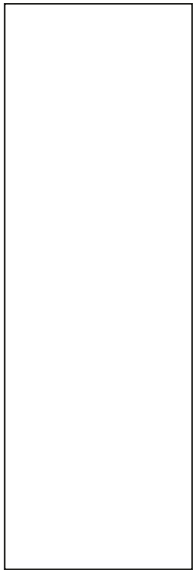

100x300cm / 39"x118"
slimtech 5plus

2

FINITURE

finishes / surfaces / Oberfläche

LEV

SAT

2

COLORI

colors / couleurs / Farben

Total White

Total Black



I
AB EFGH
J LMNOPQ
ST VWXY
Zabod fghk
l mnpq r s v
wxy 123456
7890087654

ABSOLUTE

TOTAL WHITE

100x300cm / 39"x118"
sat

100x100cm / 39"x39"
sat

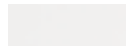

64/
65

TOTAL BLACK
100x100cm / 39"x39"
sat





ABSOLUTE

TOTAL WHITE

100x300cm / 39"x118"
lev

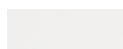

ABSOLUTE

66/
67

GRES PORCELLANATO LAMINATO UGL

Laminated porcelain stoneware UGL / Grès laminé
UGL / Laminierter Feinsteinzeug UGL

SPESSORE

Thickness / Epaisseur / Stärke

5,5 mm → slimtech 5plus



STONALIZZAZIONE

Shading / Denuançage / Spielfarbig

ANSI A137.3

FINITURA LEV

Lev surface finish / Finition LEV

LEV Oberfläche

Ideale per rivestimenti e per pavimenti in ambienti residenziali.

Suitable for wall coverings and floors in residential applications.

Idéal pour revêtements et sols pour locaux résidentiels privés.

Für Wand und Boden im Wohnbereich geeignet.

FINITURA SAT

Sat surface finish / Finition SAT

SAT Oberfläche

Ideale per rivestimenti e per pavimenti in ambienti residenziali e commerciale leggero.

Suitable for wall coverings and floors in both residential and light-commercial applications.

Idéal pour revêtements et sols pour locaux résidentiels privés et commercial léger.

Für Wand und Boden im Wohn- und leichte kommerzielle Bereiche geeignet / Ideal para.

FUGA MINIMA CONSIGLIATA

Minimum suggested joint

Joint minimum conseillé

Empfohlene Fugenbreite

POSA A PARETE / Wall / Mur / Wand

1 mm (INDOOR) → slimtech 5plus

POSA A PAVIMENTO / Floor / Sol / Boden

2 mm (INDOOR) → slimtech 5plus

OUTDOOR

vedi Manuale Tecnico Slimtech

see Slimtech Technical Manual

RESISTENZA ALLO SCIVOLAMENTO

Slip resistance / Résistance au glissement

Rutschfestigkeit

ANSI A326.3

DCOF ≥ 0.42 (Sat)

LEGENDA CODICI PRODOTTO / IMBALLI

Legend product codes / Packing

Légende codes produits / Emballage

Legend Produktcodes / Verpackung

pag. 382

P R () T E C T

ANTIBATTERICO - ANTIMICROBIAL

contemporary



SRC030
100x300cm / 39"x118"



SRC010
100x100cm / 39"x39"



RE-EVOLUTION

 **LIMTECH**

spessore / thickness **3,5mm**

4

FORMATI 

sizes / formats / Formate

6

COLORI

colors / couleurs / Farben



4,9x100cm / 2"x39"
slimtech 3plus



50x100cm / 19¹/₂"x39"
slimtech 3plus

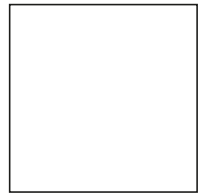

100x100cm / 39"x39"
slimtech 3plus

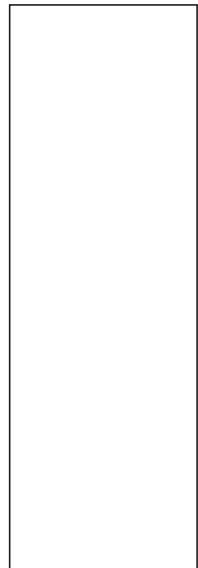

100x300cm / 39"x118"
slimtech 3plus





RE-EVOLUTION

70/
71



SRW020
100x100cm / 39"x39"



contemporary

RE-EVOLUTION



SRC020
100x300cm / 39"x118"





RE-EVOLUTION



RE-EVOLUTION

GRES PORCELLANATO LAMINATO UGL

Laminated porcelain stoneware UGL / Grès laminé UGL / Laminiertes Feinsteinzeug UGL

SPESSORE

Thickness / Epaisseur / Stärke

3,5 mm → slimtech 3plus



STONALIZZAZIONE

Shading / Denuançage / Spielfarbig

ANSI A137.3

FUGA MINIMA CONSIGLIATA

Minimum suggested joint

Joint minimum conseillé

Empfohlene Fugenbreite

POSA A PARETE / Wall / Mur / Wand

1 mm (INDOOR) → slimtech 5plus

POSA A PAVIMENTO / Floor / Sol / Boden

2 mm (INDOOR) → slimtech 5plus

OUTDOOR

vedi Manuale Tecnico Slimtech

see Slimtech Technical Manual

LEGENDA CODICI PRODOTTO / IMBALLI

Legend product codes / Packing

Légende codes produits / Emballage

Legend Produktcodes / Verpackung

pag. 386



SRC020

100x300cm / 39"x118"



SRW010

100x100cm / 39"x39"



contemporary

**GOUACHE.10
and LIBECCIO**
design
Diego Grandi



CRYSTAL WATER
100x300cm / 39"x118"

100x100cm / 39"x39"



GOUACHE.10

and LIBECCIO design Diego Grandi

 SLIMTECH

spessore / thickness **3,5mm**

4

FORMATI 

sizes / formats / Formate

7

COLORI

colors / couleurs / Farben



4,9x100cm / 2"x39"
slimtech 3plus



50x100cm / 19 1/2"x39"
slimtech 3plus



100x100cm / 39"x39"
slimtech 3plus

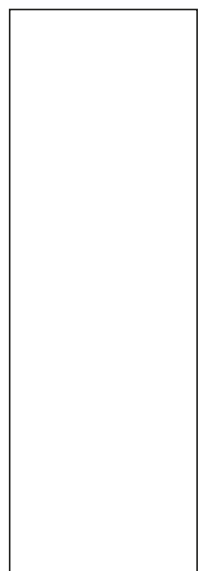

100x300cm / 39"x118"
slimtech 3plus

White Cloud

Crystal Water

Soft Sand

Deep Sea

Light Rock

Cool Rain

Black Stone

contemporary



GOUACHE.10

78/
79



DEEP SEA
100x100cm / 39"x39"



contemporary



GOUACHE.10 LIBECCIO

design
Diego Grandi



DECORI

decors / decors / dekore

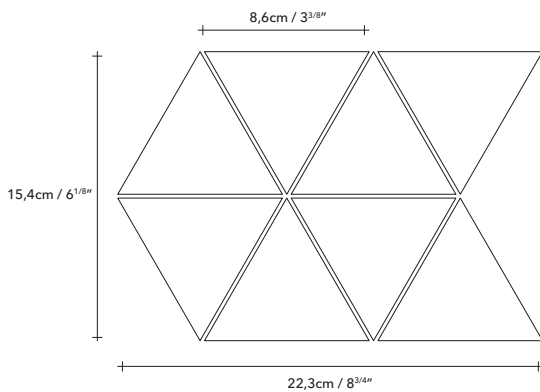

LIBECCIO
white cloud
15,4x22,3cm / 6 1/8"x8 3/4"



LIBECCIO
crystal water
15,4x22,3cm / 6 1/8"x8 3/4"



LIBECCIO 01
warm
15,4x22,3cm / 6 1/8"x8 3/4"



LIBECCIO
soft sand
15,4x22,3cm / 6 1/8"x8 3/4"



LIBECCIO
cool rain
15,4x22,3cm / 6 1/8"x8 3/4"



LIBECCIO 01
cold
15,4x22,3cm / 6 1/8"x8 3/4"



LIBECCIO
light rock
15,4x22,3cm / 6 1/8"x8 3/4"



LIBECCIO
deep sea
15,4x22,3cm / 6 1/8"x8 3/4"



LIBECCIO 02
15,4x22,3cm / 6 1/8"x8 3/4"



LIBECCIO
black stone
15,4x22,3cm / 6 1/8"x8 3/4"



LIBECCIO 03
15,4x22,3cm / 6 1/8"x8 3/4"

**GOUACHE.10****GRES PORCELLANATO LAMINATO UGL**

Laminated porcelain stoneware UGL / Grès laminé UGL / Laminiertes Feinsteinzeug UGL

SPESSORE

Thickness / Epaisseur / Stärke

3,5 mm → slimtech 3plus

**STONALIZZAZIONE**

Shading / Denuançage / Spielfarbig

ANSI A137.3**FUGA MINIMA CONSIGLIATA**

Minimum suggested joint

Joint minimum conseillé

Empfohlene Fugenbreite

POSA A PARETE / Wall / Mur / Wand

1 mm (INDOOR) → slimtech 3plus

POSA A PAVIMENTO / Floor / Sol / Boden

2 mm (INDOOR) → slimtech 3plus

OUTDOOR

vedi Manuale Tecnico Slimtech

see Slimtech Technical Manual

RESISTENZA ALLO SCIVOLAMENTO

Slip resistance / Résistance au glissement

Rutschfestigkeit

DIN 51130

R9

BCR-TORTUS $\mu > 0,40$ **ANSI A326.3**DCOF ≥ 0.42 **LEGENDA CODICI PRODOTTO / IMBALLI**

Legend product codes / Packing

Légende codes produits / Emballage

Legend Produktcodes / Verpackung

pag. 383/384

contemporary

**SHADE
and STREETS**
design
Diego Grandi



MILK
100x300cm / 39"x118"

100x100cm / 39"x39"



SHADE

and STREETS design Diego Grandi

 SLIMTECH

spessore / thickness **3,5mm**

4

FORMATI 

sizes / formats / Formate

2

COLORI

colors / couleurs / Farben



4,9x100cm / 2"x39"
slimtech 3plus



50x100cm / 19¹/₂"x39"
slimtech 3plus

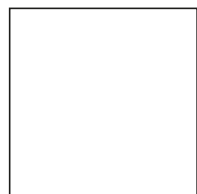

100x100cm / 39"x39"
slimtech 3plus

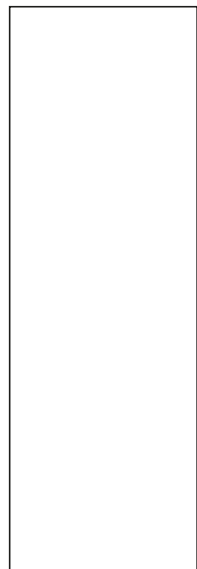

100x300cm / 39"x118"
slimtech 3plus

Milk

Black Coffee

contemporary

SHADE

MILK

100x300cm / 39"x118"

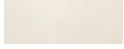

BLACK COFFEE

100x300cm / 39"x118"

100x100cm / 39"x39"







SHADE STREETS

design
Diego Grandi

STREETS KYOTO
50X100cm / 19¹/₂"X39"



STREETS MELBOURNE
50X100cm / 19¹/₂"X39"



**STREETS
MELBOURNE**
50x100cm / 19¹/₂"x39"

SHADE

GRES PORCELLANATO LAMINATO UGL

Laminated porcelain stoneware UGL / Grès laminé UGL / Laminiertes Feinsteinzeug UGL

SPESSORE

Thickness / Epaisseur / Stärke

3,5 mm → slimtech 3plus



STONALIZZAZIONE

Shading / Denuançage / Spielfarbig

ANSI A137.3

FUGA MINIMA CONSIGLIATA

Minimum suggested joint

Joint minimum conseillé

Empfohlene Fugenbreite

POSA A PARETE / Wall / Mur / Wand

1 mm (INDOOR) → slimtech 3plus

POSA A PAVIMENTO / Floor / Sol / Boden

2 mm (INDOOR) → slimtech 3plus

OUTDOOR

vedi Manuale Tecnico Slimtech

see Slimtech Technical Manual

RESISTENZA ALLO SCIVOLAMENTO

Slip resistance / Résistance au glissement

Rutschfestigkeit

DIN 51130

R9

BCR-TORTUS

$\mu > 0,40$

ANSI A326.3

DCOF ≥ 0.42

LEGENDA CODICI PRODOTTO / IMBALLI

Legend product codes / Packing

Légende codes produits / Emballage

Legend Produktcodes / Verpackung

pag. 386/387

stone



SILVER FLOW

100x300cm / 39"x118"

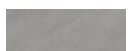

WATERFALL

SLIMTECH | **P R O T E C T**
ANTIBATTERICO - ANTIMICROBIAL

spessore / thickness **5,5mm**

3

FORMATI ^{RT}

sizes / formats / Formate

4

COLORI

colors / couleurs / Farben



50x100cm / 19¹/₂"x39"
slimtech 5plus

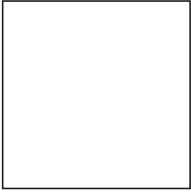

100x100cm / 39"x39"
slimtech 5plus



100x300cm / 39"x118"
slimtech 5plus

Ivory flow

Silver flow

Gray flow

Dark flow

stone

WATERFALL

GRAY FLOW

100x100cm / 39"x39"
nat



DARK FLOW

100x300cm / 39"x118"
nat



GRAY FLOW

100x100cm / 39"x39"
nat









WATERFALL

92/
93

GRAY FLOW
100x100cm / 39"x39"
nat



IVORY FLOW
100x100cm / 39"x39"
nat

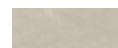

DARK FLOW
100x300cm / 39"x118"
nat

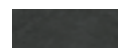



WATERFALL

NEST IVORY FLOW

ettagono
L 25cm / 10"
50x43,5cm / 19¹/₂"x17"

triangolo
L 25cm / 10"

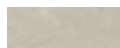

DARK FLOW
60x120cm / 24"x48"
lapp rett.



WATERFALL

94/
95

GRES PORCELLANATO LAMINATO UGL

Laminated porcelain stoneware UGL / Grès laminé
UGL / Laminierter Feinsteinzeug UGL

SPESSORE

Thickness / Epaisseur / Stärke

5,5 mm → slimtech 5plus



STONALIZZAZIONE



Shading / Denuançage / Spielfarbig

ANSI A137.3

FUGA MINIMA CONSIGLIATA

Minimum suggested joint

Joint minimum conseillé

Empfohlene Fugenbreite

POSA A PARETE / Wall / Mur / Wand

1 mm (INDOOR) → slimtech 5plus

POSA A PAVIMENTO / Floor / Sol / Boden

2 mm (INDOOR) → slimtech 5plus

OUTDOOR

vedi Manuale Tecnico Slimtech

see Slimtech Technical Manual

RESISTENZA ALLO SCIVOLAMENTO

Slip resistance / Résistance au glissement

Rutschfestigkeit

DIN 51130

R10

BCR-TORTUS

$\mu > 0,40$

ANSI A326.3

DCOF ≥ 0.42

LEGENDA CODICI PRODOTTO / IMBALLI

Legend product codes / Packing

Légende codes produits / Emballage

Legend Produktcodes / Verpackung

pag. 390

P R () T E C T

ANTIBATTERICO - ANTIMICROBIAL

stone



NATURALE

100x300cm / 39"x118"

100x100cm / 39"x39"



LAPPATA

50x100cm / 19¹/₂"x39"

4,9x100cm / 2"x39"



BASALTINA STONE PROJECT



spessore / thickness **3,5mm**

4
FORMATI LRT^{T}
sizes / formats / Formate

4
COLORI
colors / couleurs / Farben



4,9x100cm / 2"x39"
slimtech 3plus



50x100cm / 19¹/₂"x39"
slimtech 3plus

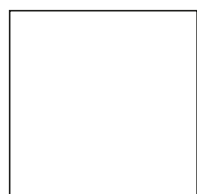

100x100cm / 39"x39"
slimtech 3plus

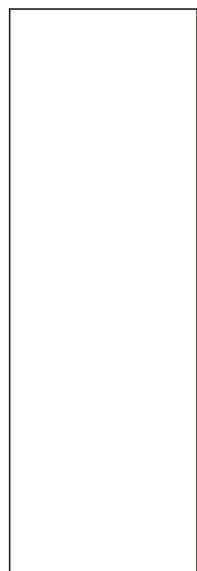

100x300cm / 39"x118"
slimtech 3plus



Sabbaiata



Naturale



Stuccata



Lappata

BASALTINA STONE PROJECT



NATURALE

100x300cm / 39"x118"

100x100cm / 39"x39"

mosaico striscia
25x50cm / 10"x19^{1/2}"



LAPPATA

100x300cm / 39"x118"









BASALTINA STONE PROJECT

STUCCATA
100x300cm / 39"x118"

100x100cm / 39"x39"
mosaico striscia
25x50cm / 10"x19^{1/2}"
mosaico listello
25x50cm / 10"x19^{1/2}"



NATURALE
50x100cm / 19^{1/2}"x39"

100x100cm / 39"x39"



BASALTINA STONE PROJECT

MOSAICI

mosaics / mosaïques / Mosaik

MOSAICO
QUADRO
sabbiaia
25x25cm /
10"x10"



MOSAICO
MATTONE
sabbiaia
25x25cm /
10"x10"



MOSAICO
STRISCIA
sabbiaia
25x50cm /
10"x19 1/2"



MOSAICO
LISTELLO
sabbiaia
25x50cm /
10"x19 1/2"



MOSAICO
QUADRO
naturale
25x25cm /
10"x10"

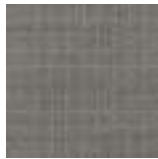

MOSAICO
MATTONE
naturale
25x25cm /
10"x10"



MOSAICO
STRISCIA
naturale
25x50cm /
10"x19 1/2"



MOSAICO
LISTELLO
naturale
25x50cm /
10"x19 1/2"



MOSAICO
QUADRO
stuccata
25x25cm /
10"x10"



MOSAICO
MATTONE
stuccata
25x25cm /
10"x10"



MOSAICO
STRISCIA
stuccata
25x50cm /
10"x19 1/2"



MOSAICO
LISTELLO
stuccata
25x50cm /
10"x19 1/2"

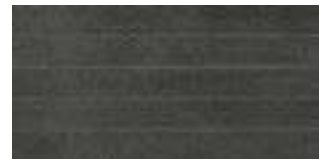

MOSAICO
QUADRO
lappata
25x25cm /
10"x10"



MOSAICO
MATTONE
lappata
25x25cm /
10"x10"

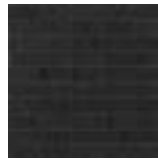

MOSAICO
STRISCIA
lappata
25x50cm /
10"x19 1/2"

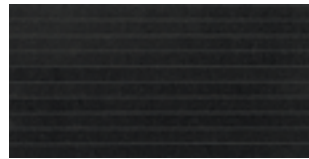

MOSAICO
LISTELLO
lappata
25x50cm /
10"x19 1/2"



MOSAICI

mosaics / mosaïques / Mosaik

MOSAICO
INOX
sabbata
25x25cm /
10"x10"



MOSAICO
SATIN
sabbata
25x25cm /
10"x10"



MOSAICO
METAL
chiaro (naturale)
50x100cm /
19 1/2"x39"



MOSAICO
GLITTER
chiaro (sabbata)
50x100cm /
19 1/2"x39"



MOSAICO
INOX
naturale
25x25cm /
10"x10"



MOSAICO
SATIN
naturale
25x25cm /
10"x10"



MOSAICO
INOX
stuccata
25x25cm /
10"x10"

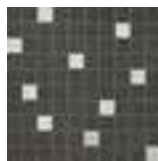

MOSAICO
PEARL
stuccata
25x25cm /
10"x10"



MOSAICO
INOX
lappata
25x25cm /
10"x10"

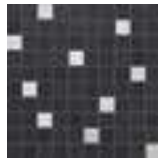

MOSAICO
PEARL
lappata
25x25cm /
10"x10"



MOSAICO
METAL
scuro (lappata)
50x100cm /
19 1/2"x39"



MOSAICO
GLITTER
scuro (stuccata)
50x100cm /
19 1/2"x39"





BASALTINA STONE PROJECT

SABBIATA

100x300cm / 39"x118"

60x120cm / 24"x48" (11mm)

mosaico mattone

25x50cm / 10"x19¹/₂"



BASALTINA STONE PROJECT

GRES PORCELLANATO LAMINATO UGL

Laminated porcelain stoneware UGL / Grès laminé UGL / Laminiertes Feinsteinzeug UGL

SPESSORE

Thickness / Epaisseur / Stärke

3,5 mm → slimtech 3plus



STONALIZZAZIONE

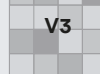

Shading / Denuançage / Spielfarbig

ANSI A137.3

FUGA MINIMA CONSIGLIATA

Minimum suggested joint

Joint minimum conseillé

Empfohlene Fugenbreite

POSA A PARETE / Wall / Mur / Wand

1 mm (INDOOR) → slimtech 5plus

POSA A PAVIMENTO / Floor / Sol / Boden

2 mm (INDOOR) → slimtech 5plus

OUTDOOR

vedi Manuale Tecnico Slimtech

see Slimtech Technical Manual

RESISTENZA ALLO SCIVOLAMENTO

Slip resistance / Résistance au glissement

Rutschfestigkeit

DIN 51130

R9

BCR-TORTUS

$\mu > 0,40$

ANSI A326.3

DCOF ≥ 0.42

LEGENDA CODICI PRODOTTO / IMBALLI

Legend product codes / Packing

Légende codes produits / Emballage

Legend Produktcodes / Verpackung

pag. 382/383

marble

**TIMELESS MARBLE
and FILIGRANE**
design
Philippe Nigro



PIETRA GRAY
100x300cm / 39"x118"
sat



TIMELESS MARBLE

and FILIGRANE design Philippe Nigro

SLIMTECH | **P R () T E C T**
ANTIBATTERICO - ANTIMICROBIAL

spessore / thickness **5,5mm**

3

FORMATI ^{LR^T}

sizes / formats / Formate

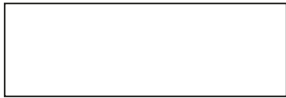

50x150cm / 19¹/₂"x59"
slimtech 5plus

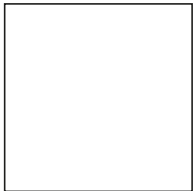

100x100cm / 39"x39"
slimtech 5plus

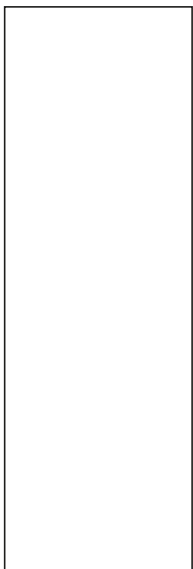

100x300cm / 39"x118"
slimtech 5plus

2

FINITURE

finishes / surfaces / Oberfläche

LEV

SAT

7

COLORI

colors / couleurs / Farben

Lasa Bright

Onice Venus

Calacatta Gold Extra

Pietra Gray

Safari Amande

Statuario White

Travertino Classico

marble



TIMELESS MARBLE

STATUARIO WHITE
100x300cm / 39"x118"
lev

50x150cm / 19 1/2"x59"
lev





TRAVERTINO CLASSICO
50x150cm / 19¹/₂"x59"
lev



marble

TIMELESS MARBLE



ONICE VENUS
100x300cm / 39"x118"
lev





marble



TIMELESS MARBLE

CALACATTA GOLD EXTRA

100x100 cm / 39"x39"

lev

100x300cm / 39"x118"

lev



SAFARI AMANDE

50x150cm / 19¹/₂"x59"

lev





TIMELESS MARBLE

ONICE VENUS
100x100cm / 39"x39"
sat





CALACATTA BUTTERFLY
100x300cm / 39"x118"
lev



marble



TIMELESS MARBLE FILIGRANE

design
Philippe Nigro





**PEARL
LASA BRIGHT**
100x300cm / 39"x118"
sat



marble





TIMELESS MARBLE

118/
119

HYPHEN CALACATTA GOLD EXTRA

100x300cm / 39"x118"

sat



PEARL CALACATTA GOLD EXTRA

100x300cm / 39"x118"

sat



HYPHEN PIETRA GRAY

100x300cm / 39"x118"

sat





TIMELESS MARBLE FILIGRANE

design
Philippe Nigro

PEARL SAT



FORMATO

size / format / Format

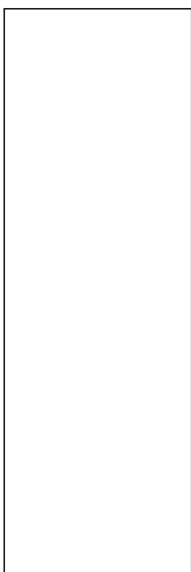

100x300cm / 39"x118"
slimtech 5plus



Pearl
onice venus



Pearl
lasa bright



Pearl
calacatta gold extra

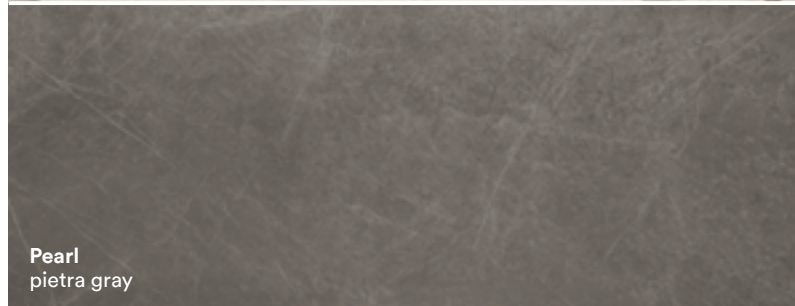

Pearl
pietra gray



Pearl
statuario white

HYPHEN

SAT

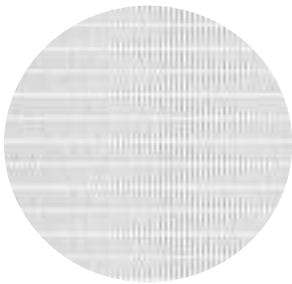

Hyphen
onice venus



Hyphen
lasa bright



Hyphen
calacatta gold extra



Hyphen
pietra gray



Hyphen
statuario white

FORMATO

size / format / Format

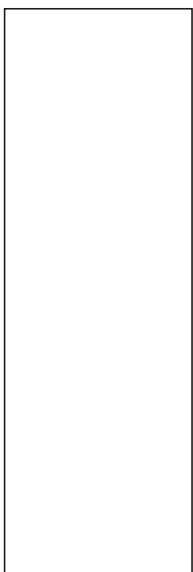

100x300cm / 39"x118"
slimtech 5plus

TIMELESS MARBLE BUTTERFLY

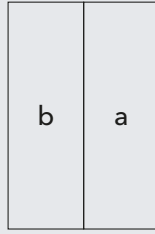

CALACATTA BUTTERFLY B
100x300cm / 39"x118"



CALACATTA BUTTERFLY A
100x300cm / 39"x118"



TIMELESS MARBLE

GRES PORCELLANATO LAMINATO UGL

Laminated porcelain stoneware UGL / Grès laminé UGL / Laminiertes Feinsteinzeug UGL

SPESSORE

Thickness / Epaisseur / Stärke

5,5 mm → slimtech 5plus



STONALIZZAZIONE

Shading / Denuançage / Spielfarbig

ANSI A137.3

FINITURA LEV

Lev surface finish / Finition LEV

LEV Oberfläche

Ideale per rivestimenti e per pavimenti in ambienti residenziali.

Suitable for wall coverings and floors in residential applications.

Idéal pour revêtements et sols pour locaux résidentiels privés.

Für Wand und Boden im Wohnbereich geeignet.

FINITURA SAT

Sat surface finish / Finition SAT

SAT Oberfläche

Ideale per rivestimenti e per pavimenti in ambienti residenziali e commerciale leggero.

Suitable for wall coverings and floors in both residential and light-commercial applications.

Idéal pour revêtements et sols pour locaux résidentiels privés et commercial léger.

Für Wand und Boden im Wohn- und leichte kommerzielle Bereiche geeignet / Ideal para.

FUGA MINIMA CONSIGLIATA

Minimum suggested joint

Joint minimum conseillé

Empfohlene Fugenbreite

POSA A PARETE / Wall / Mur / Wand

1 mm (INDOOR) → slimtech 5plus

POSA A PAVIMENTO / Floor / Sol / Boden

2 mm (INDOOR) → slimtech 5plus

OUTDOOR

vedi Manuale Tecnico Slimtech

see Slimtech Technical Manual

RESISTENZA ALLO SCIVOLAMENTO

Slip resistance / Résistance au glissement

Rutschfestigkeit

ANSI A326.3

DCOF ≥ 0.42 (sat)

LEGENDA CODICI PRODOTTO / IMBALLI

Legend product codes / Packing

Légende codes produits / Emballage

Legend Produktcodes / Verpackung

pag. 388/389

PROTECT

ANTIBATTERICO - ANTIMICROBIAL

wood



COFFEE WOOD

20x200cm / 8"x79"

Type-32 coffee W 25



WOOD-STOCK

SLIMTECH | **P R O T E C T**
ANTIBATTERICO - ANTIMICROBIAL

spessore / thickness **5,5mm**

4

FORMATI LRT^{T}

sizes / formats / Formate



20x100cm / 8"x39"
slimtech 5plus



20x150cm / 8"x59"
slimtech 5plus



20x200cm / 8"x79"
slimtech 5plus



33x300cm / 13"x118"
slimtech 5plus

5

COLORI

colors / couleurs / Farben

Snow Wood



Vintage Wood



Cream Wood



Coffee Wood



Honey Wood



wood



WOOD-STOCK

CREAM WOOD
33x300cm / 13" x 118"





wood





WOOD-STOCK

SNOW WOOD
20x200cm / 8"x79"



wood



WOOD-STOCK

VINTAGE WOOD
20x150cm / 8"x59"



130/
131

HONEY WOOD
33x300cm / 13"x118"



wood



WOOD-STOCK

COFFEE WOOD

20x200cm / 8"x79"

Type-32 coffee W 25



WOOD-STOCK

132/
133

GRES PORCELLANATO LAMINATO UGL

Laminated porcelain stoneware UGL / Grès laminé UGL / Laminiertes Feinsteinzeug UGL

SPESSORE

Thickness / Epaisseur / Stärke

5,5 mm → slimtech 5plus



STONALIZZAZIONE

Shading / Denuançage / Spielfarbig



ANSI A137.3

FUGA MINIMA CONSIGLIATA

Minimum suggested joint

Joint minimum conseillé

Empfohlene Fugenbreite

POSA A PARETE / Wall / Mur / Wand

1 mm (INDOOR) → slimtech 5plus

POSA A PAVIMENTO / Floor / Sol / Boden

2 mm (INDOOR) → slimtech 5plus

OUTDOOR

vedi Manuale Tecnico Slimtech

see Slimtech Technical Manual

RESISTENZA ALLO SCIVOLAMENTO

Slip resistance / Résistance au glissement

Rutschfestigkeit

DIN 51130

R10

BCR-TORTUS

$\mu > 0,40$

ANSI A326.3

DCOF ≥ 0.42

LEGENDA CODICI PRODOTTO / IMBALLI

Legend product codes / Packing

Légende codes produits / Emballage

Legend Produktcodes / Verpackung

pag. 391

PROTECT

ANTIBATTERICO - ANTIMICROBIAL

wood

TYPE 32
design
Diego Grandi

HONEY

Beta Warm 11

Delta Cold 30

Alfa Warm 03

Gamma Cold 22



TYPE 32

design Diego Grandi

 SLIMTECH

spessore / thickness 5,5mm

1

FORMATO ^{RT}

size / format / Formate



20x200cm / 8"x79"
slimtech 5plus

4

COLORI

colors / couleurs / Farben



wood





TYPE 32

SNOW

Delta Warm 28

Delta Cold 29

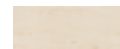

wood





TYPE 32

COFFEE

Delta Cold 32

Delta Warm 25



HONEY

Beta Warm 11

Delta Cold 30

Alfa Warm 03

Gamma Cold 22



wood



TYPE 32

VINTAGE

Alfa Cold 07

Delta Warm 26







TYPE 32

design **Diego Grandi**

COLORI
colors / couleurs / farben

SNOW

ALFA

BETA

GAMMA

DELTA

05

13

21

29



COLD

04

12

20

28



WARM

HONEY

ALFA

BETA

GAMMA

DELTA

06

14

22

30



COLD

03

11

19

27



WARM

COLORI

colors / couleurs / farben

VINTAGE

ALFA

BETA

GAMMA

DELTA

07

15

23

31



COLD

02

10

18

26



WARM

COFFEE

ALFA

BETA

GAMMA

DELTA

08

16

24

32



COLD

01

09

17

25



WARM

wood



TYPE 32

SNOW

Delta Warm 28

Delta Cold 29



TYPE 32

GRES PORCELLANATO LAMINATO UGL

Laminated porcelain stoneware UGL / Grès laminé UGL / Laminiertes Feinsteinzeug UGL



Type 32 è un progetto per sua natura versatile, in grado di interagire con l'ambiente ed i suoi abitanti e di modificarsi nelle forme e nei colori. Come il legno, anche Type 32, nel registrare il passare del tempo, restituisce una superficie dall'aspetto vintage, un effetto "vissuto" tipico dei pavimenti legati alla nostra memoria. Questa peculiarità rende la collezione originale ed esclusiva, con una personalità irripetibile. In Type 32 i mutamenti rincorrono e ricordano il tempo trascorso.

Type 32 is a design which, due to its versatile nature, is able to interact with the environment and its inhabitants, as well as change in terms of shapes and colors. Like aged wood, Type 32 also gives an area a vintage look, a "lived in" effect which is typical of floors with a touch of nostalgia. This peculiarity makes the collection unique and original, with a special personality. With Type 32 the changes take us back and remind us of times gone by.

Grâce à sa nature polyvalente, Type 32 est en mesure d'interagir avec l'environnement et ses habitants et de modifier ses propres formes et couleurs. Tel le bois sous l'effet du temps qui passe, Type 32 révèle une surface à l'aspect vintage, avec un effet de « vécu » caractéristique des sols liés à notre mémoire. Cette particularité en fait une collection originale et exclusive, dont la personnalité est incomparable. Avec Type 32, les changements recherchent et évoquent le temps passé.

Type 32 ist ein vielseitiges Projekt, das in der Lage ist, mit der Umwelt und ihren Bewohnern zu interagieren und sowohl Form als auch Farbe zu wechseln. So wie es bei Holz der Fall ist, hinterlässt das Vergehen der Zeit auch bei Type 32 einen Vintage-Look auf der Bodenoberfläche, eine "gelebte" Wirkung, die typisch für Fußböden unserer Erinnerungen ist. Dieser Charakterzug erweist sich als grundlegend für diese originale und exklusive Kollektion unwiderstehlicher Persönlichkeit. Bei Type 32 folgt und gedenkt Wandel der verstrichenen Zeit.

SPESSORE

Thickness / Epaisseur / Stärke
5,5 mm → slimtech 5plus



STONALIZZAZIONE

Shading / Denuançage / Spielfarbig

ANSI A137.3

Informazioni tecniche per l'utilizzo pag. 370

Technical information for use.
Informations techniques pour l'utilisation.
Technische Zusammenarbeit.

Ideale per rivestimenti e per pavimenti in ambienti residenziali.

Suitable for wall coverings and floors in residential applications.

Idéal pour revêtements et sols pour locaux résidentiels privés.

Für Wand und Boden im Wohnbereich geeignet.

FUGA MINIMA CONSIGLIATA

Minimum suggested joint
Joint minimum conseillé
Empfohlene Fugenbreite

POSA A PARETE / Wall / Mur / Wand
1 mm (INDOOR) → slimtech 5plus

POSA A PAVIMENTO / Floor / Sol / Boden
2 mm (INDOOR) → slimtech 5plus

OUTDOOR

vedi Manuale Tecnico Slimtech
see Slimtech Technical Manual

LEGENDA CODICI PRODOTTO / IMBALLI

Legend product codes / Packing
Légende codes produits / Emballage
Legend Produktcodes / Verpackung

pag. 389

NAIVE
design
Patrick Norguet



NAIVE BLACK
100x300cm / 39"x118"



NAIVE

design Patrick Norguet

 SLIMTECH

spessore / thickness **5,5mm**

2

FORMATI 

sizes / formats / Formate

4

COLORI

colors / couleurs / Farben

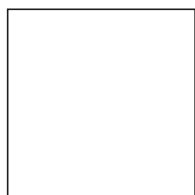

100x100cm / 39"x39"
slimtech 5plus

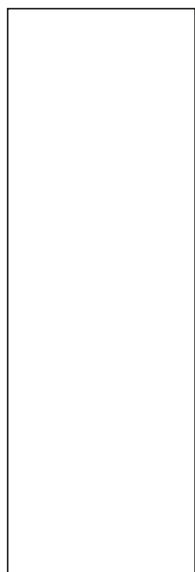

100x300cm / 39"x118"
slimtech 5plus

Naive Blue



Naive Terra



Naive Grey



Naive Black

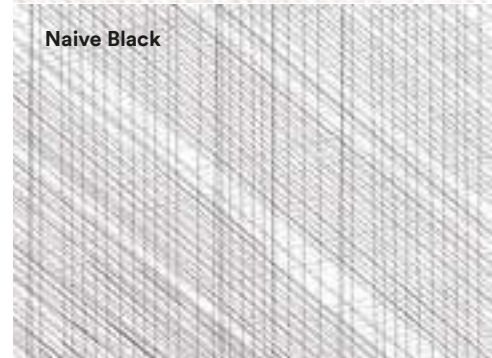



NAIVE

NAIVE GREY

100x300cm / 39"x118"

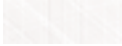

148 / 149



NAIVE BLUE

100x300cm / 39"x118"







NAIVE

NAIVE TERRA
100x300cm / 39"x118"





NAIVE

NAIVE BLACK
100x300cm / 39"x118"



NAIVE

GRES PORCELLANATO LAMINATO UGL

Laminated porcelain stoneware UGL / Grès laminé UGL / Laminiertes Feinsteinzeug UGL



SPESSORE

Thickness / Epaisseur / Stärke

5,5 mm → slimtech 5plus



STONALIZZAZIONE

Shading / Denuançage / Spielfarbig

ANSI A137.3

FUGA MINIMA CONSIGLIATA

Minimum suggested joint

Joint minimum conseillé

Empfohlene Fugenbreite

POSA A PARETE / Wall / Mur / Wand

1 mm (INDOOR) → slimtech 5plus

POSA A PAVIMENTO / Floor / Sol / Boden

2 mm (INDOOR) → slimtech 5plus

OUTDOOR

vedi Manuale Tecnico Slimtech

see Slimtech Technical Manual

Ideale per rivestimenti e per pavimenti in ambienti residenziali e commerciale leggero.

Suitable for wall coverings and floors in both residential and light-commercial applications.

Idéal pour revêtements et sols pour locaux résidentiels privés et commercial léger.

Für Wand und Boden im Wohn- und leichte kommerzielle Bereiche geeignet / Ideal para.

LEGENDA CODICI PRODOTTO / IMBALLI

Legend product codes / Packing

Légende codes produits / Emballage

Legend Produktcodes / Verpackung

pag. 384

LINES and WAVES
design
Patrick Norguet

LINE BLUE
100x300cm / 39"x118"



LINES AND WAVES

design Patrick Norguet

 SLIMTECH

spessore / thickness **3,5mm**

1

FORMATO ^{RT}

size / format / Format

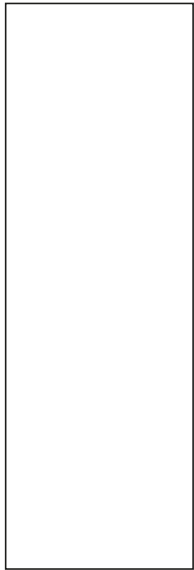

100x300cm / 39"x118"
slimtech 3plus

LINES

2

COLORI

colors / couleurs / Farben

WAVES

2

COLORI

colors / couleurs / Farben

Line Blue

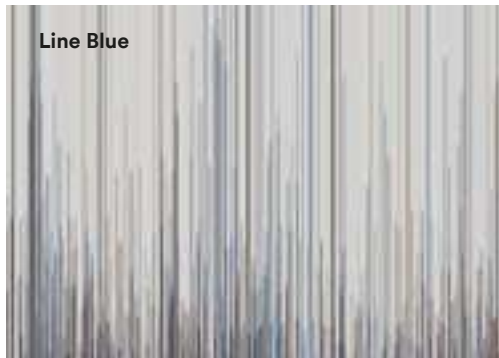

Line Grey

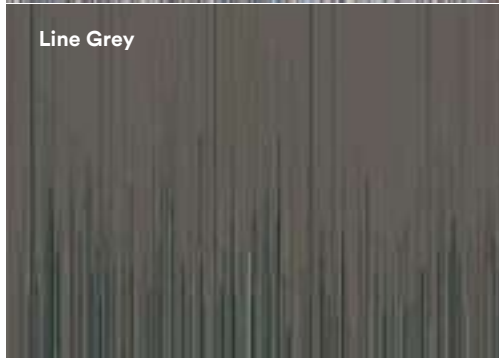

Wave Blue

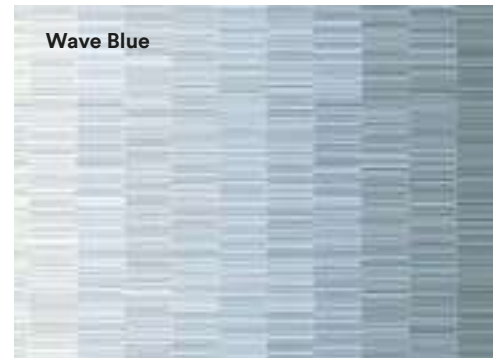

Wave Grey







LINES

156 /
157

LINE GREY
100x300cm / 39"x118"





LINES

design
Patrick Norguet

LINE BLUE
100x300cm / 39"x118"



LINE GREY
100x300cm / 39"x118"

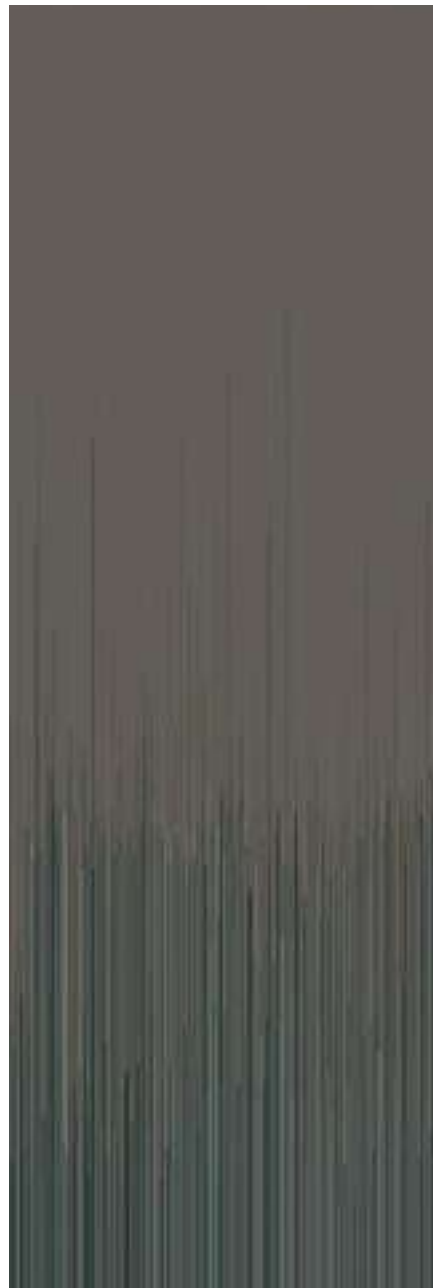

LINE BLUE
100x300cm / 39"x118"







WAVES

WAVE BLUE
100x300cm / 39"x118"



WAVE GREY
100x300cm / 39"x118"





WAVES
design
Patrick Norguet

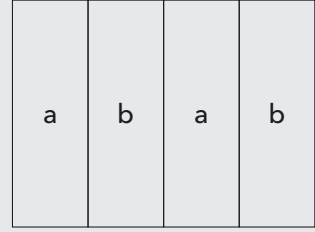

WAVE BLUE A
100x300cm / 39"x118"

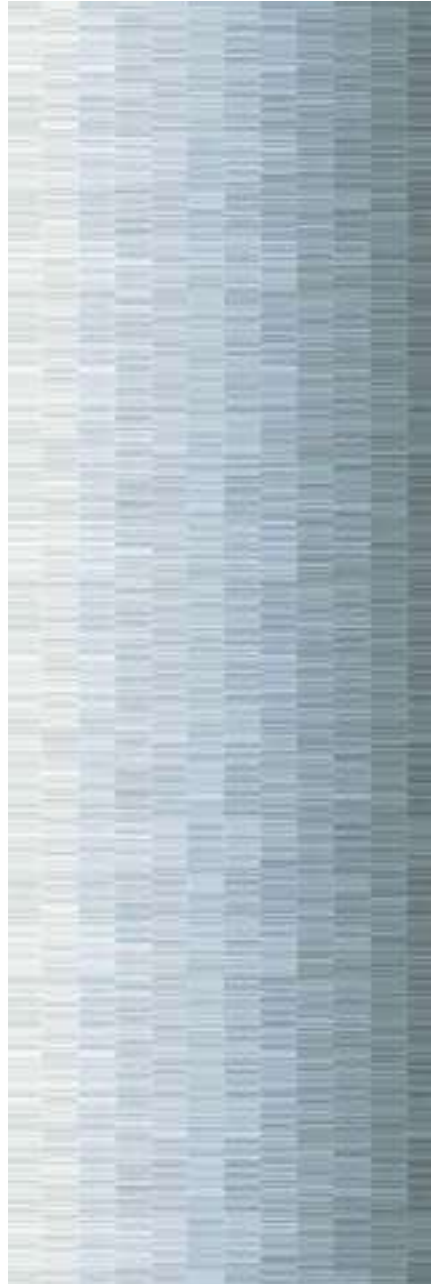

WAVE BLUE B
100x300cm / 39"x118"

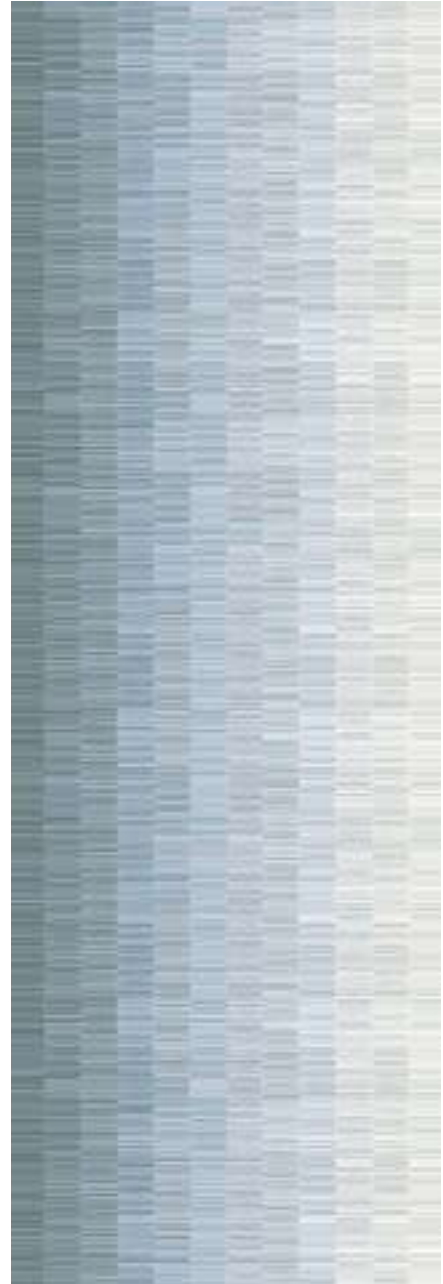

a	b	a	b
---	---	---	---

WAVE GREY A
100x300cm / 39"x118"



WAVE GREY B
100x300cm / 39"x118"



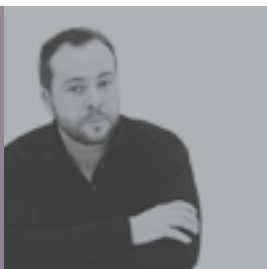

WAVES

WAVE GREY

100x300cm / 39"x118"



LINES AND WAVES

GRES PORCELLANATO LAMINATO UGL

Laminated porcelain stoneware UGL / Grès laminé UGL / Laminiertes Feinsteinzeug UGL

SPESSORE

Thickness / Epaisseur / Stärke

3,5 mm → slimtech 3plus



STONALIZZAZIONE

Shading / Denuançage / Spielfarbig

ANSI A137.3

FUGA MINIMA CONSIGLIATA

Minimum suggested joint

Joint minimum conseillé

Empfohlene Fugenbreite

POSA A PARETE / Wall / Mur / Wand

1 mm (INDOOR) → slimtech 5plus

OUTDOOR

vedi Manuale Tecnico Slimtech

see Slimtech Technical Manual

LEGENDA CODICI PRODOTTO / IMBALLI

Legend product codes / Packing

Légende codes produits / Emballage

Legend Produktcodes / Verpackung

pag. 384 Lines

pag. 390 Waves

NEST
design Hok product design



ettagono
L 50cm / 19¹/₂"

triangolo
L 50cm / 19¹/₂"

NEST

design Hok Product Design

S LIMTECH

6

FORMATI \square \square \square

sizes / formats / Formate

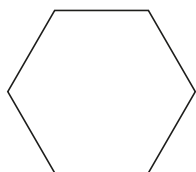

*ESAGONO

L 50cm / 19^{1/2}"

100x86,6cm / 39"x34^{1/8}"



*ESAGONO

L 25cm / 10"

50x43,2cm / 19^{1/2}"x17"



*ESAGONO

L 6,2cm / 2^{1/2}"

12,5x10,8cm / 5"x4^{1/4}"

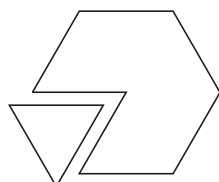

*ETTAGONO

L 50cm / 19^{1/2}"

100x86,6cm / 39"x34^{1/8}"

*TRIANGOLO

L 50cm / 19^{1/2}"



*ETTAGONO

L 25cm / 10"

50x43,2cm / 19^{1/2}"x17"

*TRIANGOLO

L 25cm / 10"



*ETTAGONO

L 6,2cm / 2^{1/2}"

12,5x10,8cm / 5"x4^{1/4}"

*TRIANGOLO

L 6,2cm / 2^{1/2}"

REALIZZABILE CON LE SERIE:

Can be made with the following collections: /

Réalisable avec les séries: /

Realisierbar mit den Serien:

ABSOLUTE

BASALTINA STONE PROJECT

GOUACHE.10

RE-EVOLUTION

SHADE

TAKE CARE

TIMELESS MARBLE

WATERFALL

NEST



NEST

DECORO REALIZZATO CON GRES PORCELLANATO LAMINATO UGL

Decor made with laminated porcelain stoneware UGL / Décor réalisé avec grès laminé UGL
Das Dekor ist aus hergestellt laminiertes Feinsteinzeug UGL

SPESSORE

Thickness / Epaisseur / Stärke

3,5 mm → slimtech 3plus

5,5 mm → slimtech 5plus



FUGA MINIMA CONSIGLIATA

Minimum suggested joint

Joint minimum conseillé

Empfohlene Fugenbreite

POSA A PARETE / Wall / Mur / Wand

1 mm (INDOOR) → slimtech 3plus - slimtech 5plus

POSA A PAVIMENTO / Floor / Sol / Boden

2 mm (INDOOR) → slimtech 3plus - slimtech 5plus

Il decoro ottenuto da Slimtech Absolute, Basaltina Stone Project, Gouache.10, RE-evolution, Shade, Take Care, Timeless Marble, Waterfall è utilizzabile per pavimenti e rivestimenti.

The decors made using Slimtech Absolute, Basaltina Stone Project, Gouache.10, RE-evolution, Shade, Take Care, Timeless Marble, Waterfall can be used for both floor and wall applications.

Les décors produit en utilisant Slimtech Absolute, Basaltina Stone Project, Gouache.10, RE-evolution, Shade, Take Care, Timeless Marble, Waterfall sont utilisables au mur ainsi qu'au sol.

Dekor aus den Kollektionen Slimtech Absolute, Basaltina Stone Project, Gouache.10, RE-evolution, Shade, Take Care, Timeless Marble, Waterfall ist für Wand und Boden geeignet.

I decori NEST sono venduti esclusivamente a scatola intera. All'interno delle scatole sono presenti pezzi dello stesso colore.

The NEST decors are sold only in full boxes. In each box there is only one color.

Les décors NEST sont vendus uniquement par boîte entière. Dans les boîtes sont présents des articles de la même couleur.

Die Dekore NEST werden ausschließlich in kompletten Kartoneinheiten verkauft. Die Kartons enthalten jeweils eine Farbe.

LEGENDA CODICI PRODOTTO / IMBALLI

Legend product codes / Packing

Légende codes produits / Emballage

Legend Produktcodes / Verpackung

pag. 385



ettagono
L 25cm / 10"
50x43,5cm / 19¹/₂" x 17"

triangolo
L 25cm / 10"

MAUK
design
Diego Grandi



LAPPATA

spina
8,7x13,5x25,8cm / 3^{3/8}" x 5^{3/8}" x 10^{1/8}"

cuadra
57,6cm / 22^{5/8}"



NATURALE

cuadra
57,6cm / 22^{5/8}"



SABBIATA

cuadra
57,6cm / 22^{5/8}"

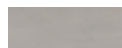

MAUK

design Diego Grandi

 SLIMTECH

spessore / thickness **3,5mm**

3

FORMATI 

sizes / formats / Formate

3

COLORI

colors / couleurs / Farben

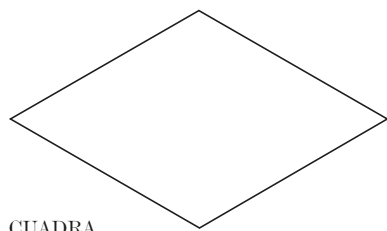

CUADRA
57,6cm / 22^{5/8}"
slimtech 3plus

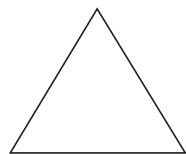

ESA
38,3cm / 15^{1/8}"
slimtech 3plus



SPINA
base maggiore 25,8cm/10^{1/8}"
base minore 13,5cm/5^{3/8}"
lati 8,7cm/3^{3/8}"
slimtech 3mm

Sabbiata

Naturale

Lappata





MAUK

172/
173

SABBIATA
cuadra
57,6cm / 22^{5/8}"

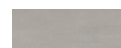

NATURALE
cuadra
57,6cm / 22^{5/8}"



LAPPATA
cuadra
57,6cm / 22^{5/8}"

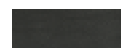



SABBIATA

LAPPATA

spina

8,7x13,5x25,8cm / 3³/₈"x5³/₈"x10¹/₈"

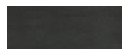

MAUK

GRES PORCELLANATO LAMINATO UGL

Laminated porcelain stoneware UGL / Grès laminé UGL / Laminiertes Feinsteinzeug UGL

SPESSORE

Thickness / Epaisseur / Stärke

3,5 mm → slimtech 3plus (cuadra - esa)



FUGA MINIMA CONSIGLIATA

Minimum suggested joint

Joint minimum conseillé

Empfohlene Fugenbreite

POSA A PARETE / Wall / Mur / Wand

1 mm (INDOOR) → slimtech 5plus

POSA A PAVIMENTO / Floor / Sol / Boden

2 mm (INDOOR) → slimtech 5plus

OUTDOOR

vedi Manuale Tecnico Slimtech

see Slimtech Technical Manual



STONALIZZAZIONE

Shading / Denuançage / Spielfarbig

ANSI A137.3

LEGENDA CODICI PRODOTTO / IMBALLI

Legend product codes / Packing

Légende codes produits / Emballage

Legend Produktcodes / Verpackung

pag. 385



SLIMTECH

LEALAB

Con LeaLab il gres laminato Slimtech diventa materiale mutante in grado di rispondere ad esigenze progettuali inaspettate e sorprendenti. La competenza tecnica di Lea Ceramiche e la sua naturale attitudine a produrre prodotti di qualità, costituiscono assoluta garanzia per supportare, in ogni sua fase, qualsiasi progetto in architettura, come nel residenziale. LeaLab rappresenta l'avanguardia nella personalizzazione del prodotto ceramico. Per ogni informazione: www.leaceramiche.com.

With Lealab, Slimtech laminated porcelain stoneware becomes a material that transforms to suit the needs of the most unexpected and surprising project requirements. Lea Ceramiche's technical skills and its natural penchant for producing high quality products are an absolute guarantee of its ability to support, at every stage, any architectural or residential project. LeaLab is at the forefront in the personalization of ceramic products. For more informations please visit www.leaceramiche.com.





Avec LeaLab, le grès laminé Slimtech devient un matériau changeant en mesure de répondre à des exigences de projet inattendues et étonnantes. La compétence technique de Lea Ceramiche et sa propension naturelle à fabriquer des produits de qualité constituent une garantie absolue pour assumer n'importe quelle phase d'un projet, aussi bien en architecture que dans le domaine résidentiel. LeaLab représente l'avant-garde de la personnalisation du produit en céramique. Pour toute information : www.leaceramiche.com.

Mit LeaLab wird das laminierte Feinsteinzeug Slimtech zu einem mutierenden Material, in der Lage den unerwarteten und überraschenden Designanforderungen entgegen zu kommen. Die technische Kompetenz von Lea Ceramiche und ihre natürliche Fähigkeit, qualitativ hochwertige Produkte herzustellen, bilden eine absolute Garantie, um jedes architektonische Projekt in jeder hase, wie im Wohnbereich, zu unterstützen. LeaLab steht für den Fortschritt bei der Personalisierung von keramischen Produkten. Für weitere Informationen: www.leaceramiche.com.

DESTINAZIONI D'USO

intended uses
destinations d'usage
anwendungen

		POSA A PAVIMENTO FLOOR INSTALLATION POSE AU SOL FUSSBODENVERLEGUNG			POSA A PARETE WALL INSTALLATION POSE AU MUR WANDVERLEGUNG		
<p>Prodotti con finiture particolari possono prevedere limitazioni nelle destinazioni d'uso. Verificare nei singoli cataloghi di collezione.</p> <p>Products with special finishes can have limitations depending on their area of application. Refer to specific collection catalogues.</p> <p>Les produits avec des finitions particulières peuvent prévoir des limites d'application. Contrôler dans chaque catalogue de la collection.</p> <p>Für Produkte mit besonderem Finish können endungseinschränkungen gelten. Bitte in den einzelnen Katalogen der Kollektionen nachprüfen.</p>	<p>IN INTERNO</p>	<p>IN ESTERNO</p>			<p>IN INTERNO</p>		
	<p>Situazioni applicative sia per interventi di NUOVA COSTRUZIONE che di RISTRUTTURAZIONI con posa in sovrapposizione a pavimenti preesistenti.</p>	<p>RESIDENZIALE (cucine, bagni, living, aree comuni condominiali ed ogni altro ambiente di uso residenziale). slimtech 3plus slimtech 5plus</p>	<p>COMMERCIALE LEGGERO (uffici, uffici aperti al pubblico, sale d'attesa, negozi, bagni, sale di ristoranti, autosaloni, bar, cinema, ambulatori/cliniche). slimtech 3plus slimtech 5plus</p>	<p>COMMERCIALE INTENSIVO (aree comuni di centri commerciali, hall di alberghi, mense, fast food, discoteche, ospedali) ad esclusione di zone sottoposte al passaggio di carichi pesanti concentrati (ad es. carrelli a ruote dure). slimtech 5plus</p>	<p>A condizione che le superfici siano coperte (es. loggie, balconi coperti, ecc.) e perfettamente impermeabilizzate. Si consiglia l'utilizzo di formati non superiori a 50x50 cm. slimtech 3plus slimtech 5plus</p>	<p>Situazioni applicative sia per interventi di NUOVA COSTRUZIONE che di RISTRUTTURAZIONI con posa in sovrapposizione a rivestimenti preesistenti.</p>	<p>Qualunque ambiente residenziale e commerciale, in situazioni dove non si devono praticare fori e/o tagli interni. slimtech 3plus slimtech 5plus</p>
	<p>For NEW BUILDINGS and REFURBISHING, for installation on pre-existing floors.</p>	<p>RESIDENTIAL (kitchens, bathrooms, living rooms, common apartment block areas and any other residential environment). slimtech 3plus slimtech 5plus</p>	<p>LIGHT COMMERCIAL (offices, offices open to the general public, waiting rooms, shops, bathrooms, restaurant dining rooms, car showrooms, bars, cinemas, surgeries/clinics). slimtech 3plus slimtech 5plus</p>	<p>INTENSIVE COMMERCIAL (common areas of shopping centres, hotel halls, canteens, fast food restaurants, dance clubs, hospitals) with the exception of areas subject to heavy concentrated loads (e.g. trolleys with hard wheels). slimtech 5plus</p>	<p>Upon condition that surfaces are sheltered (e.g. loggias, covered balconies, etc.) and made totally impervious. The use of sizes that are not larger than 50x50cm is recommended. slimtech 3plus slimtech 5plus</p>	<p>For NEW BUILDINGS and REFURBISHING, for installation on pre-existing walls.</p>	<p>Any residential and commercial environment, in situations where holes and/or cuts are not necessary. slimtech 3plus slimtech 5plus</p>
	<p>Application dans des NOUVELLES CONSTRUCTIONS ou des RESTRUCTURATIONS, avec pose sur des sols préexistants.</p>	<p>RÉSIDENTIEL (cuisines, salles de bains, salles de séjour, zones de copropriété collectives et tout autre espace à usage résidentiel). slimtech 3plus slimtech 5plus</p>	<p>COMMERCIAL LÉGER (bureaux, bureaux ouverts au public, salles d'attente, magasins, salles de bains, salles de restaurants, salons automobiles, bars, cinémas, dispensaires/cliniques). slimtech 3plus slimtech 5plus</p>	<p>COMMERCIAL INTENSIF (zones communes de centres commerciaux, halls d'hôtels, cantines, fast-foods, discothèques, hôpitaux, sauf les zones soumises au passage de charges lourdes concentrées (ex. : chariots à roues dures). slimtech 5plus</p>	<p>À condition que les surfaces soient couvertes (loggias, balcons couverts, etc.) et parfaitement imperméabilisées. Il est conseillé d'utiliser des formats non supérieurs à 50x50 cm. slimtech 3plus slimtech 5plus</p>	<p>Application dans des NOUVELLES CONSTRUCTIONS ou des RESTRUCTURATIONS, avec pose sur des supports préexistants.</p>	<p>Tout espace résidentiel et commercial, dans des endroits où il n'est pas nécessaire d'effectuer des trous et/ou des découpes internes. slimtech 3plus slimtech 5plus</p>
<p>Anwendungslösungen sowohl für NEUBAUTEN als auch für RENOVIERUNGEN mit Verlegung auf vorhandenen Bodenbelägen.</p>	<p>WOHNBEREICHE (Küchen, Badezimmer, Wohnzimmer, Gemeinschaftsflächen in Mehrfamilienhäusern und alle sonstigen Wohnbereiche). slimtech 3plus slimtech 5plus</p>	<p>LEICHTE GEWERBLICHE ANWENDUNGEN (Büros, Wartezimmer, Geschäfte, Toiletten, Gaststätten, Autohäuser, Cafés, Kinos, Praxen/Kliniken). slimtech 3plus slimtech 5plus</p>	<p>INTENSIVE GEWERBLICHE ANWENDUNGEN (gemeinschaftsbereiche in einkaufszentren, hotelhallen, kantinen, fastfood-restaurants, diskotheken, krankenhäuser), mit ausnahme von bereichen mit schwerlastverkehr (z.b. stapler mit hartgummirädern). slimtech 5plus</p>	<p>Die Verlegung in Außenbereichen ist möglich, wenn die Oberflächen überdacht und vollkommen abgedichtet sind (überdachte Balkons, Veranden, usw.). Es sollten keine größeren Formate als 50x50 cm verwendet werden. slimtech 3plus slimtech 5plus</p>	<p>Anwendungslösungen sowohl für NEUBAUTEN als auch für RENOVIERUNGEN mit Verlegung auf vorhandenen Wandverkleidungen.</p>	<p>Alle Wohn- und Gewerbebereiche, in Situationen, die keine Bohrungen und/oder Innenschnitte verlangen. slimtech 3plus slimtech 5plus</p>	
	<p>EN INTÉRIEUR</p>	<p>EN EXTÉRIEUR</p>			<p>EN INTÉRIEUR</p>		
	<p>INNENBEREICH</p>	<p>AUSSENBEREICH</p>			<p>INNENBEREICH</p>		

			DESTINAZIONI SPECIALI SPECIAL USES UTILISATIONS SPÉCIALES SPEZIELLE VERWENDUNGSZWECKE				
							
	IN ESTERNO			FACCIAE VENTILATE	RIVESTIMENTI TERMICI A CAPPOTTO	RIVESTIMENTI VASCHE E PISCINE	SUPERFICI DA RIVESTIRE NEL SETTORE DELL'ARREDAMENTO
Qualunque ambiente residenziale e commerciale, in situazioni dove si devono praticare fori e/o tagli interni.	In situazioni dove non si devono praticare fori e/o tagli interni e con formati fino a 100x100 cm. slimtech 3plus slimtech 5plus	In situazioni dove si devono praticare fori e/o tagli interni e/o per formati grandi. slimtech 3plus slimtech 5plus	In funzione delle specifiche del progetto, in abbinamento a sistemi costruttivi indicati da Panariagroup e approvati dalla Direzione Lavori.	slimtech 3plus slimtech 5plus	slimtech 3plus slimtech 5plus	slimtech 3plus slimtech 5plus	slimtech 3plus slimtech 5plus
	EXTERIORS			VENTILATED FACADES	THERMAL INSULATION SYSTEMS	POOL AND SWIMMING POOL TILING	FOR FURNITURE SURFACES
Any residential and commercial environment, in situations where holes and/or cuts are necessary.	In situations where holes and/or cuts are not necessary and with sizes up to 100 x 100 cm. slimtech 3plus slimtech 5plus	In situations where holes and/or cuts are necessary and/or for large sizes. slimtech 3plus slimtech 5plus	Depending on project specifications and in combination with the construction systems recommended by Panariagroup and approved by the Installation Supervisor.	slimtech 3plus slimtech 5plus	slimtech 3plus slimtech 5plus	slimtech 3plus slimtech 5plus	slimtech 3plus slimtech 5plus
	EN EXTÉRIEUR			FAÇADES VENTILÉES	REVÊTEMENTS THERMIQUES À MUR-MANTEAU	REVÊTEMENTS BAIGNOIRES ET PISCINES	SURFACES À REVÊTIR DANS LE SECTEUR DE LA DÉCORATION
Tout espace résidentiel et commercial, dans des endroits où il est nécessaire d'effectuer des trous et/ou des découpes internes.	Dans les situations où il ne faut pas percer de trous ni pratiquer de découpes internes et avec des formats jusqu'à 100x100 cm. slimtech 3plus slimtech 5plus	Dans les situations où il faut percer des trous ou pratiquer des découpes internes ou pour de grands formats. slimtech 3plus slimtech 5plus	En fonction des caractéristiques du projet et en combinaison avec les systèmes de construction indiqués par Panariagroup et approuvés par les maîtres d'oeuvre.	slimtech 3plus slimtech 5plus	slimtech 3plus slimtech 5plus	slimtech 3plus slimtech 5plus	slimtech 3plus slimtech 5plus
	AUSSENBEREICH			HINTERLÜFTETE FASSADEN	WÄRMEDÄMMVERBUND-SYSTEME	VERKLEIDUNG VON BECKEN UND SCHWIMMBECKEN	FLÄCHEN, DIE IM RAHMEN DER INNENEINRICHTUNG VERKLEIDET WERDEN
Alle Wohn- und Gewerbebereiche, in Situationen, die Bohrungen und/oder Innenschnitte verlangen.	In Situationen, in denen keine internen Bohrungen und/oder Schnitte gefertigt werden müssen und mit Formaten bis 100x100 cm. slimtech 3plus slimtech 5plus	In Situationen, in denen interne Bohrungen und/oder Schnitte gefertigt werden müssen und/oder für Großformate. slimtech 3plus slimtech 5plus	In Funktion der Projektangaben und in Kombination mit Konstruktionssystemen, die Panariagroup vorgibt und die Arbeitsleitung genehmigt.	slimtech 3plus slimtech 5plus	slimtech 3plus slimtech 5plus	slimtech 3plus slimtech 5plus	slimtech 3plus slimtech 5plus