

General Catalogue / 2018



Not just for surfaces

MAXFINE
FMG FABBRICA
MARMI E GRANITI iris

02	Product / Company profile
22	Photo gallery
22	Kitchen / Bathroom
34	Hospitality / Wellness
56	Indoor / Outdoor furniture
70	Boat interiors
76	Wall cladding
81	Collections
83	Marble inspiration
147	Stone inspiration
171	Iron inspiration
179	Design inspiration
194	Technical information



Not just for surfaces



Beyond imagination

Una materia così innovativa da abbattere i confini tra superfici per architettura e arredamento. Forza più leggerezza, formati enormi e spessore sottile: per fare pavimenti, rivestimenti, arredi e finiture. Non solo superfici.

Une matière si innovante qu'elle élimine les frontières entre surfaces dans le domaine de l'architecture et de l'ameublement. La force allée à la légèreté, des formats géants et une grande finesse des épaisseurs: idéal pour réaliser des sols, revêtements, décorations ou finitions. Et pas seulement des surfaces.

A material so innovative that it breaks down the barriers between surfaces for architecture and furnishing. Strength plus lightness, very large sizes and a low thickness to make floors, walls, furnishings and finishings. Not just surfaces.

Eine Materie, die so innovativ ist, dass sie die Grenzen zwischen Oberflächen für die Architektur und die Einrichtung aufhebt. Stärke und Leichtigkeit, riesige Formate und dabei besonders dünn: für Fußböden, Verkleidungen, Einrichtungen und Details. Nicht nur Oberflächen.

1

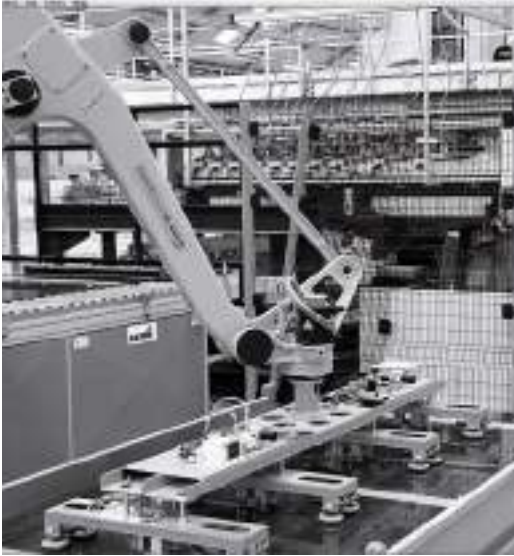

Know
how

2



Technology



Un gruppo che da oltre 50 anni è il punto di riferimento mondiale nella ceramica tecnica per grandi progetti.

A group that for over 50 years has been the world-level reference point in technical ceramics for large projects.

Un groupe référence mondiale de la céramique technique pour les grands projets depuis plus de 50 ans.

Eine Gruppe, die seit über 50 Jahren weltweit führend auf dem Sektor der technischen Keramik für große Projekte ist.



Service and experience to support any project



3



Service



Forti investimenti per una struttura produttiva e logistica all'avanguardia, per offrire il meglio come qualità e design di prodotto e seguire forniture di qualsiasi entità in qualsiasi nazione.

Heavy investments for an avant-garde production and logistic structure, so as to offer the best in terms of quality and product design and to follow supplies of any size in any country.

De gros investissements pour une structure de production et de logistique d'avant-garde permettant de proposer des produits d'une qualité et d'un design d'excellence et d'effectuer des fournitures de n'importe quelle dimension partout dans le monde.

Starke Investitionen in eine absolut fortschrittliche Produktions- und Logistikstruktur, um beste Qualität und Produktdesign zu bieten und dabei Lieferungen jeder Größenordnung in der ganzen Welt vornehmen zu können.



Un reparto assistenza per progetti speciali che da decenni fornisce un servizio senza eguali, collaudato nei cantieri più impegnativi del mondo.

A service department for special projects that for decades has been providing unequalled service, put to the test at the most demanding sites in the world.

Un service d'assistance pour les projets spéciaux qui assure depuis des dizaines d'années des prestations uniques et ayant fait leur preuve sur les chantiers les plus contraignants du monde.

Der Kundendienst für Spezialprojekte, der seit Jahrzehnten einen unvergleichlichen Service bietet, der auf den schwierigsten Baustellen der Welt geprüft wurde.



6MM

10MM*

320x160 CM 0,6 CM **Not just for** surfaces

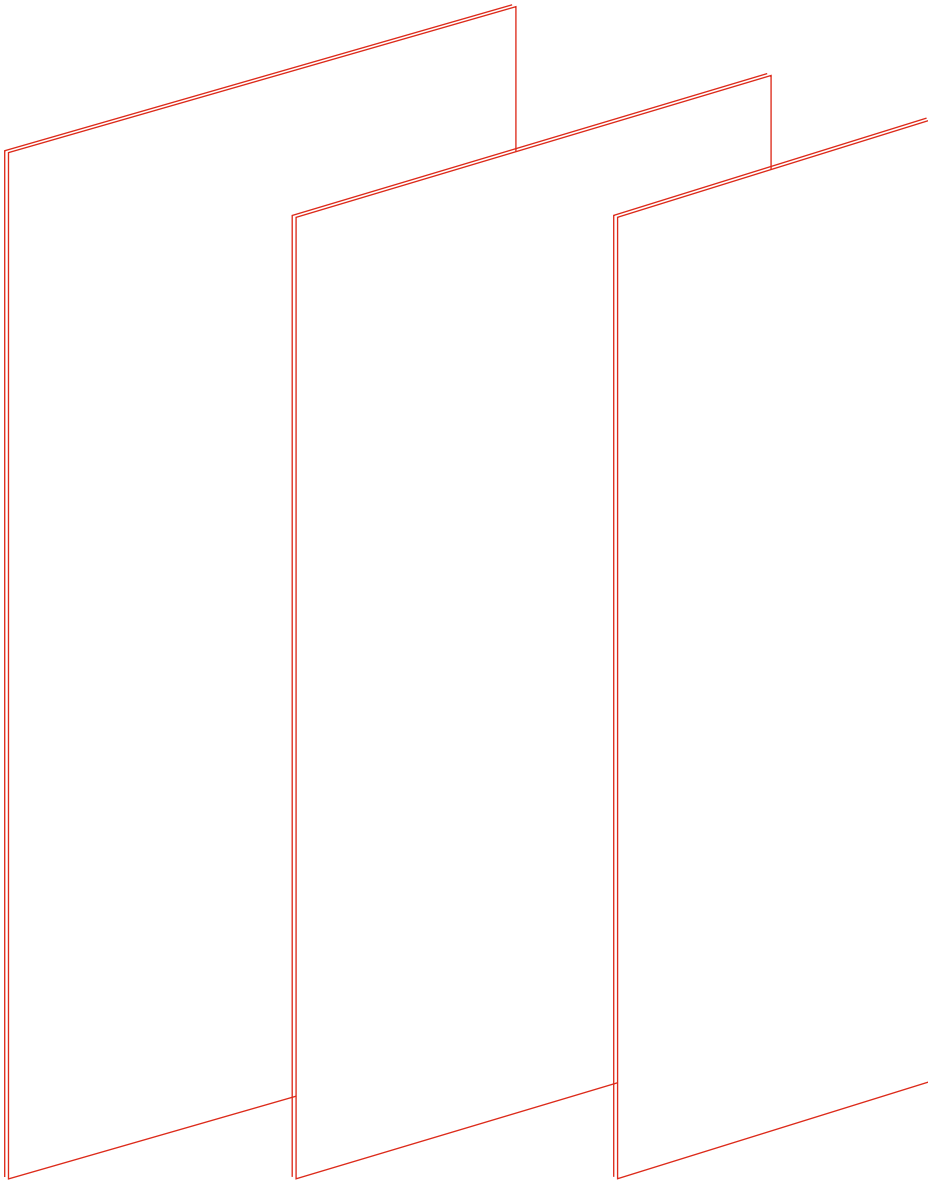

320x160*
128"x64"

300x150
120"x60"

300x100
120"x40"

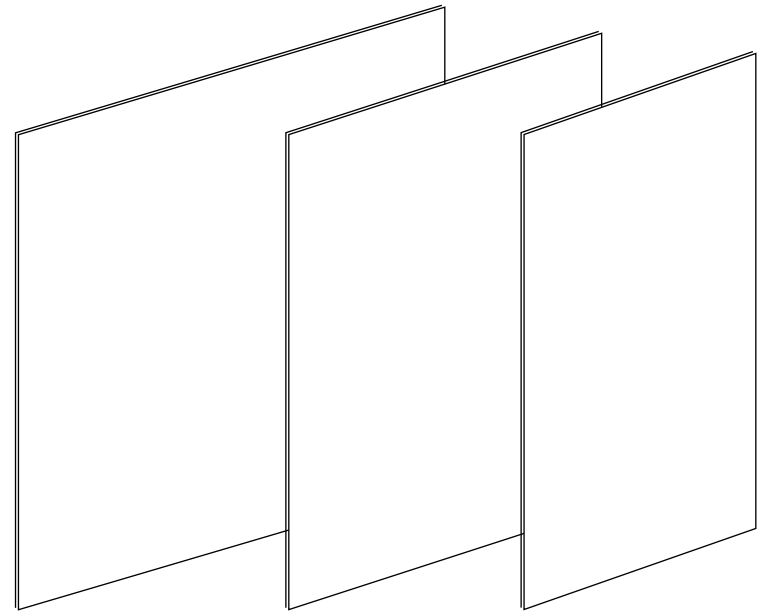

150x150
60"x60"

150x100
60"x40"

150x75
60"x30"

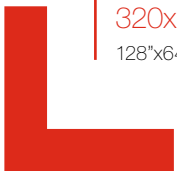

The **size** and **shape** you **need**

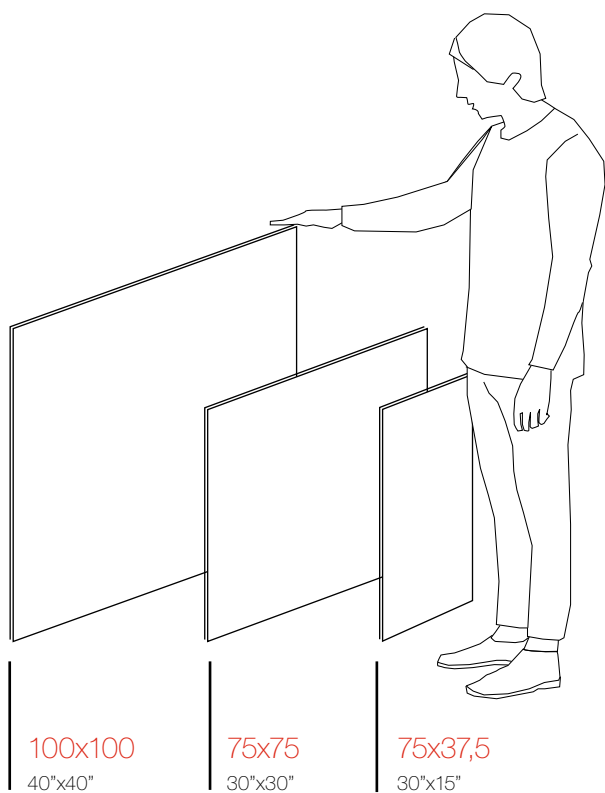

Lastre in ceramica tecnica fino a 320x160x0,6 cm. Omogenee, eterne, inalterabili, grandi, sottili e perfettamente belle.
Formati modulari per qualsiasi pavimento e rivestimento, ma anche per vestire il design.
Con **MAXFINE** tutto è realizzabile: dalle pareti di un grattacielo al tavolo per il giardino.

Dalles en céramique technique jusqu'à 320x160x0,6 cm. Homogènes, éternels, inaltérables, grands, fins et d'une beauté parfaite.
Formats modulaires parfaits non seulement pour tous les revêtements de mur ou de sol mais aussi pour habiller le design.
Avec **MAXFINE**, tout est possible : des murs d'un gratte-ciel à la table de jardin.

Technical ceramic slabs measuring up to 320 x 160 x 0.6 cm. Uniform, eternal, non-degradable, large, thin and perfectly beautiful.
Modular formats for any flooring or wall, but also for dressing a design.
With **MAXFINE** everything can be made: from the walls of a skyscraper to a garden table.

Platten aus technischer Keramik bis zu 320x160x0,6 cm. Homogen, ewig, unveränderbar, groß, dünn und von perfekter Schönheit.
Modulare Formate für jede Art von Fußboden und Verkleidung, ideal auch für Design.
Mit **MAXFINE** kann man alles machen, von den Wänden eines Hochhauses bis zum Gartentisch.

* Available upon request. Disponibile su richiesta. Réalisable sur demande. Verfügbar auf Anfrage

ACTIVE™

CLEAN AIR & ANTIBACTERIAL CERAMIC

Extra large

L'unica ceramica al mondo per pavimenti e rivestimenti antinquinante e battericida
Certificata iso 10678, iso 27448-1 e iso 27447

The only floor and wall ceramics in the world
anti-pollution and bactericidal
Certified by iso 10678, iso 27448-1 and iso 27447

La seule céramique au monde pour sols et murs antibactérienne et antipollution
Certifiée iso 10678, iso 27448-1 et iso 27447

Die einzige keramik auf der welt für boden - und wandverkleidungen umweltfreundlich und bakterientötend
Zertifikation iso 10678, iso 27448-1 und iso 27447

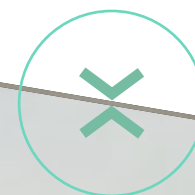

300x150

120"x60"



Anti-pollution effectiveness

EFFICACIA ANTINQUINANTE 100 mq Active = 30 alberi

In 6 ore, 100m² di ceramica Active depurano l'aria dagli Nox come 30 alberi o arbusti con una quantità di foglie pari a 22m²

(New Phytol 103 (1986) 199)

ANTI-POLLUTION EFFECTIVENESS 100 sq. m. Active = 30 trees

In 6 hours, 100m² of Active ceramic cleans as much NOx from the air as 30 trees or shrubs with a quantity of leaves amounting to 22m²

(New Phytol 103 (1986) 199)

EFFICACITÉ ANTIPOLLUTION 100 m² Active = 30 arbres

En 6 heures, 100 m² de céramique Active purifient l'air en détruisant les Nox comme le feraient 30 arbres ou arbustes ayant une quantité de feuilles égale à 22 m²

(New Phytol 103 (1986) 199)

UMWELTSCHUTZLEISTUNG 100 m² Active = 30 Bäume

In 6 Stunden reinigen 100 m² Keramik die Luft und entfernen genauso viel Nox wie 30 Bäume oder Büsche mit einem Laubwerk von 22 m²

(New Phytol 103 (1986) 199)



Antibacterial effectiveness

EFFICACIA BATTERICIDA

Nella nostra vita veniamo quotidianamente a contatto con un certo numero di batteri. Active li elimina tutti!

ANTIBACTERIAL EFFECTIVENESS

In our everyday lives we constantly come into contact with a lot of bacteria. Active gets rid of them all!

EFFICACITÉ ANTIBACTÉRIENNE

Nous sommes chaque jour en contact avec un certain nombre de bactéries. Active les supprime toutes !

BAKTERIENTÖTENDE WIRKUNG

Jeden Tag kommen wir mit einer gewissen Anzahl von Bakterien in Kontakt. Mit Active werden sie alle abgeschafft!



Self-cleaning effectiveness

EFFICACIA AUTOPULENTE Idrofilia – minor uso

La rimozione dello sporco risulta considerevolmente agevolata, con conseguente riduzione della necessità di sostanze detergenti.

SELF-CLEANING EFFECTIVENESS Hydrophilic – less use

Removing dirt ends up being a lot easier, with a consequent reduction in the need for detergents.

EFFICACITÉ AUTONETTOYAGE Hydrophilie – usage réduit

La suppression de la saleté est considérablement facilitée, ce qui réduit du même coup le besoin de substances détergentes.

SELBSTREINIGENDE WIRKUNG Hydrophil – geringer Einsatz

Der Schmutz kann einfach mit geringen Reinigungsmittelmengen entfernt werden.

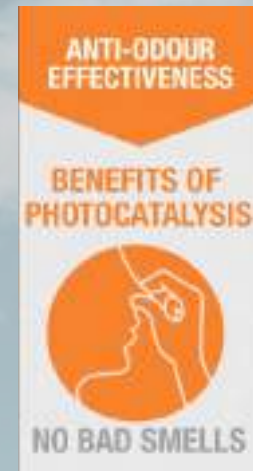

Anti-odour effectiveness

EFFICACIA ANTIODORE Benefici della fotocatalisi

NO CATTIVI ODORI

Miglioramento della qualità dell'aria grazie a una sensibile riduzione degli inquinanti tossici e degli odori derivanti dallo sporco.

ANTI-ODOUR EFFECTIVENESS Benefits of photocatalysis

NO BAD SMELLS

Better quality air thanks to a considerable reduction in the toxic pollution and the odours produced by dirt.

EFFICACITÉ ANTI-ODEUR Les bienfaits de la photocatalyse

PAS DE MAUVAISES ODEURS

Amélioration de la qualité de l'air grâce à une réduction sensible des polluants toxiques et des odeurs provenant de la saleté.

GERUCHBEKÄMPFUNG Vorteile der Fotokatalyse

KEINE GERUCHBILDUNG

Verbesserung der Luftqualität dank einer starken Verringerung der giftigen Schadstoffe und der auf Schmutz zurückzuführenden Geruchbildung.

Strength and beauty. Together.

MAXFINE è ceramica tecnica con formati extralarge e spessore sottile, con le caratteristiche del porcellanato. Le lastre di eccezionale bellezza e versatilità, non temono le ingiurie del tempo.

MAXFINE is technical ceramic featuring extra-large sizes and a low thickness, with the characteristics of porcelain stoneware. These slabs of exceptional beauty and versatility do not fear the ravages of time.

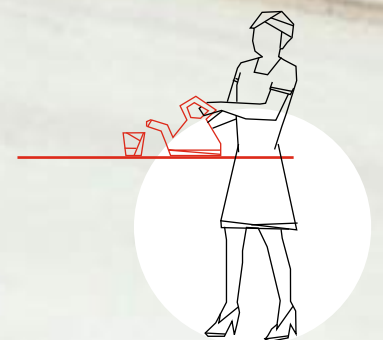
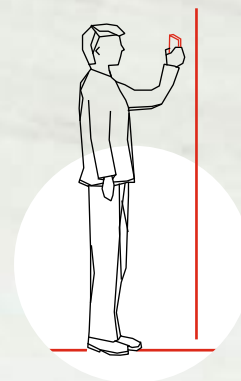
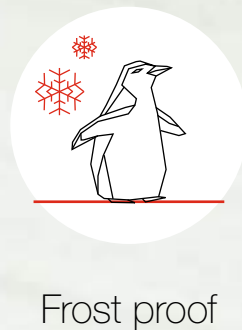

Se distinguant par ses formats extra larges et la finesse de ses épaisseurs, la céramique technique **MAXFINE** a toutes les caractéristiques de cette matière. Ces dalles d'une beauté et d'une polyvalence exceptionnelles ne craignent pas les affronts du temps.

MAXFINE ist technische Keramik im XXL-Format und besonders dünn, mit den Eigenschaften der technischen Keramik. Diese außerordentlich schönen und vielseitigen Platten sind absolut wetterfest.



Weather proof



Outstanding beauty

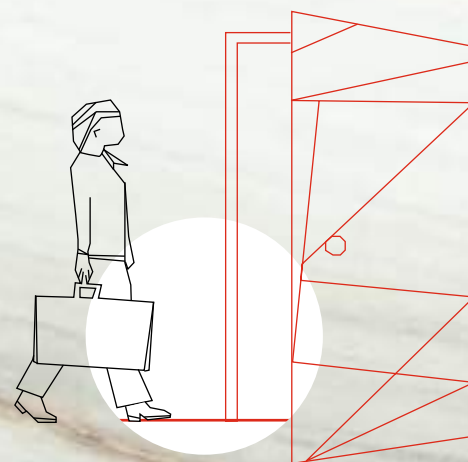

Versatile



D Design
inspiration

S Stone
inspiration

M Marble
inspiration

I Iron
inspiration



The look you need

MAXFINE offre una ricchissima varietà di effetti materici, per trovare sempre l'ispirazione giusta, senza compromessi. Ogni materia è un prototipo di bellezza: marmo, onice, metallo, pietra, legno, cemento.

Pour trouver toujours la bonne inspiration, sans aucun compromis, **MAXFINE** propose un très riche éventail d'effets « matières ». Chacune d'elles est un prototype de beauté : marbre, onyx, métal, pierre, bois, béton.

MAXFINE offers a very rich variety of textural effects so as to always find the right uncompromising inspiration. Each material is a prototype of beauty: marble, onyx, metal, stone, wood, concrete.

MAXFINE bietet eine reiche Vielfalt materischer Effekte, damit Sie kompromisslos Ihre richtige Inspiration finden können. Jede Materie ist ein Prototyp der Schönheit: Marmor, Onyx, Metall, Stein, Holz, Zement.

M Marble
inspiration



MARMITHASSOS



ONICEAVORIO



MARMIESTREMOZCREMA

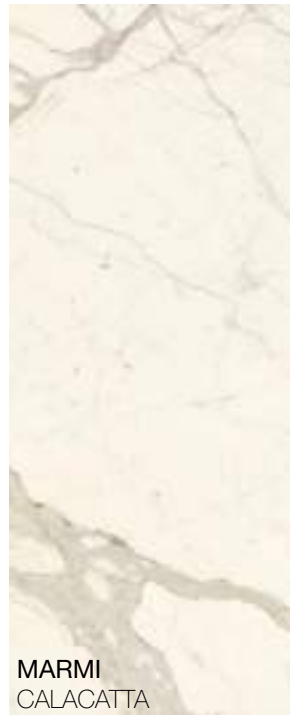

MARMICALACATTA



MARMIALPSHEART



TRAVERTINOCLASSICO



MARMIVEINEDWHITE



ONICEONICEPERLA



MARMIARABESCATO LIGHT



MARMISTATUARIO LIGHT



MARMIBIANCOVENATO EXTRA



MARMIARABESCATO

The widest range

Color range —





MARMI
ERAMOSA



MARMI
PORTORO



MARMI
STONE GREY



MARMI
BLACK VENATO

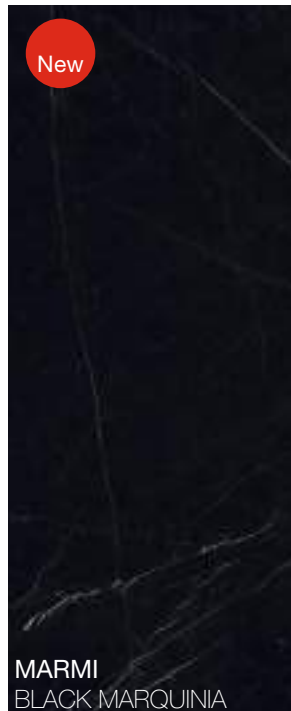

MARMI
BLACK MARQUINIA



PIETRE
LAVICA PEARL



PIETRE
LAVICA GREY



LIMESTONE
MOON



PIETRE
LAVICA BEIGE



PIETRE
LAVICA DARK



CITYSTONE
DOVE



CITYSTONE
BROWN



LIMESTONE
ASH



CITYSTONE
PEARL

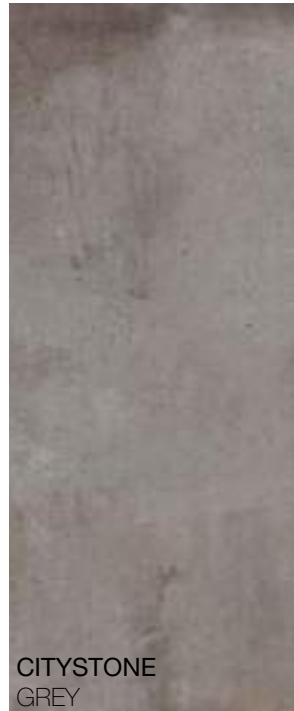

CITYSTONE
GREY



LIMESTONE
DEEP



PIETRE
LAVICA BLACK



Iron
inspiration



CORTEN



IRON
BRONZE



IRON
BLACK



IRON
GREY



Design
inspiration

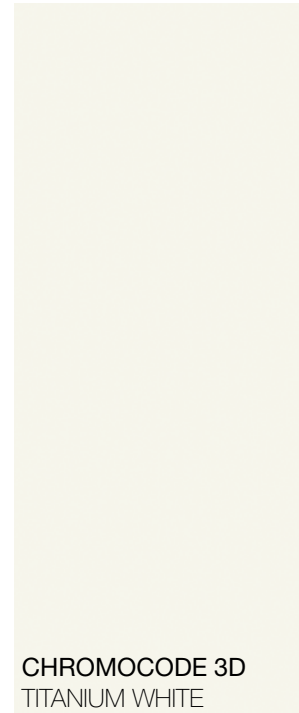

CHROMOCODE 3D
TITANIUM WHITE



ROADS
WHITE PURITY

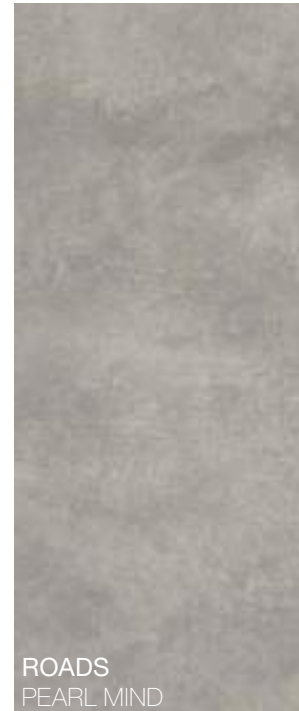

ROADS
PEARL MIND



ROADS
GREY CALM

Surface finishing



ROADS
SAND HEARTH



ROADS
COFFEE TRUTH



ROADS
DARK DEPTH

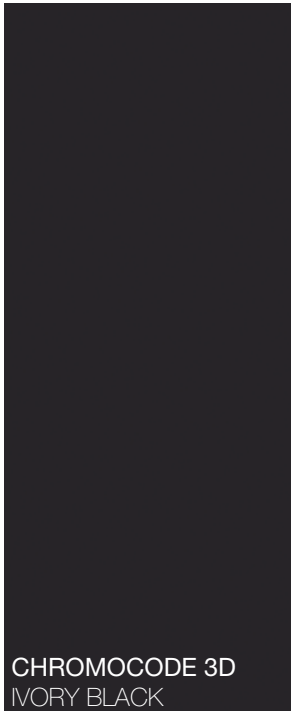

CHROMOCODE 3D
IVORY BLACK

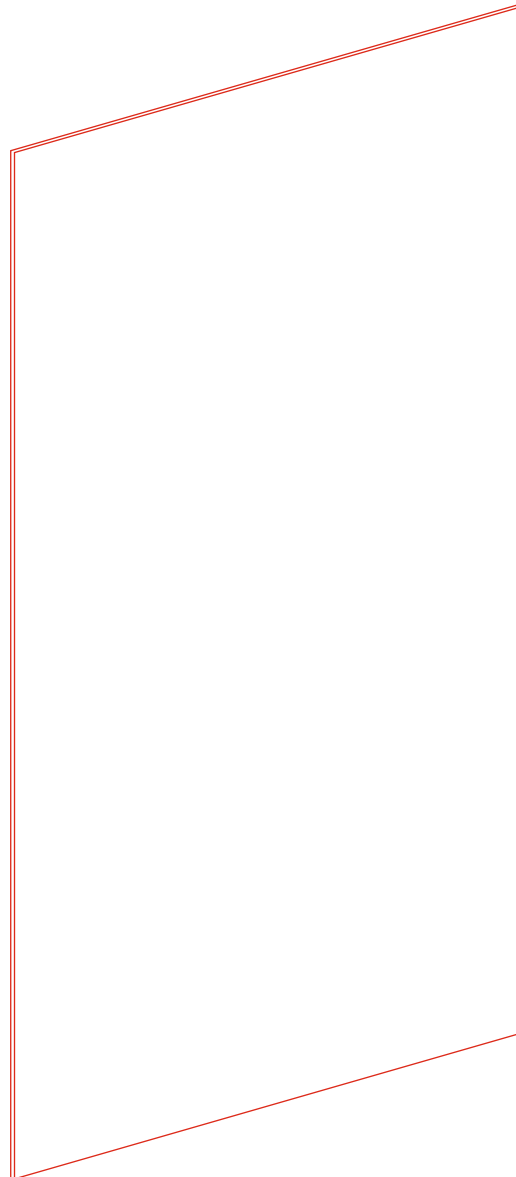

 Extra Shine effect
LU LUCIDATO
E SQUADRATO

 New soft touch effect
SY SILKY
E SQUADRATO

 Shine effect
PL PRELUCIDATO
E SQUADRATO

 Natural effect
N NATURALE
E SQUADRATO

 Textured effect
ST STRUTTURATO
R10 A+B

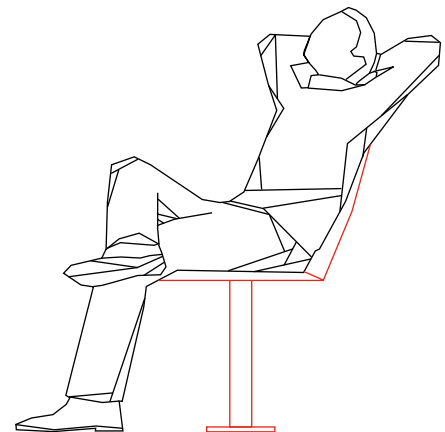

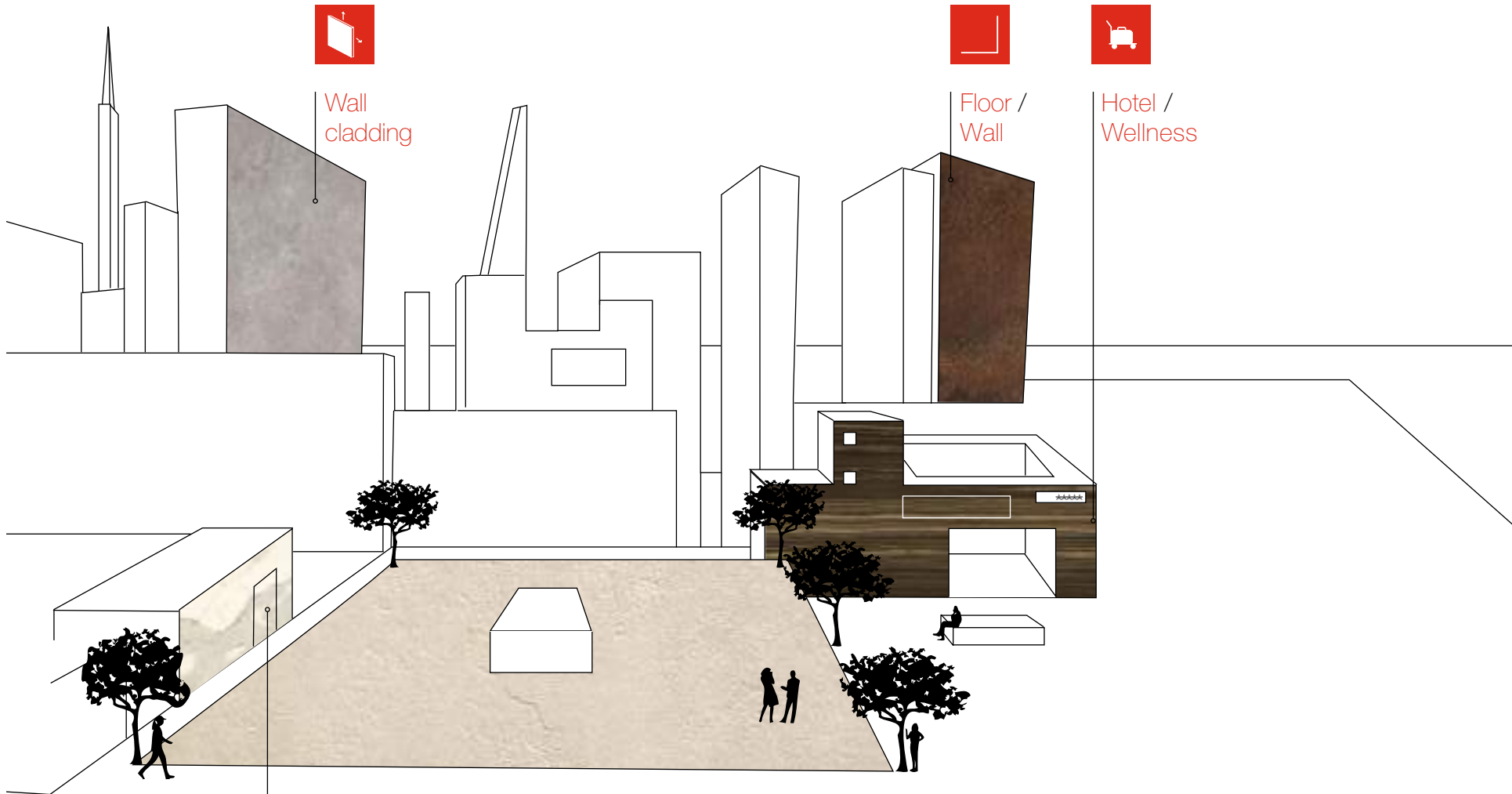

Wall
cladding



Floor /
Wall



Hotel /
Wellness

Doors

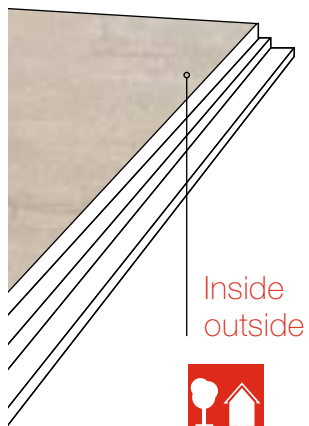

Inside
outside

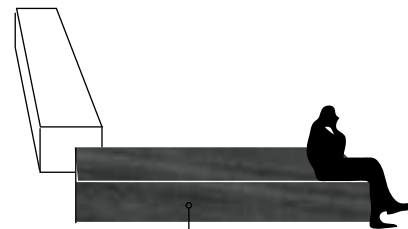

Indoor / outdoor
furniture

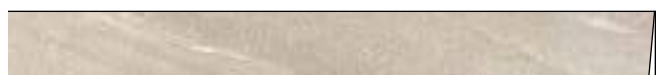
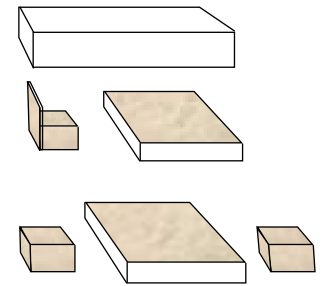



Boat interior
design

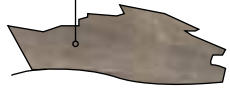

The full coordinated solutions

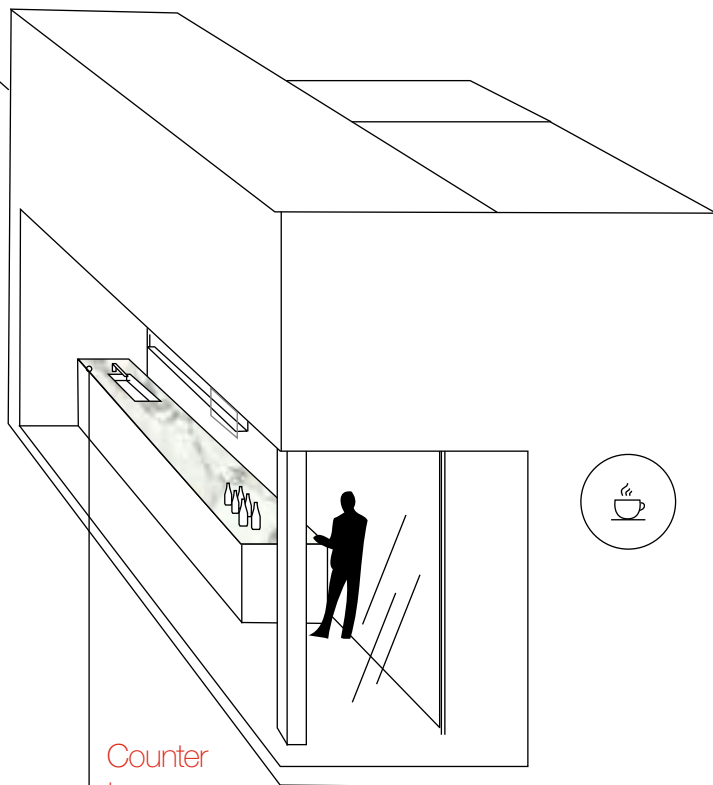

Counter
top



Lastre così innovative e versatili da abbattere i confini tra superfici per architettura e arredamento, tra interno ed esterno. Cresce la libertà di progettare, con soluzioni fino a ieri impossibili.

Slabs so innovative and versatile that they break down the barriers between surfaces for architecture and furnishing, between indoor and outdoor use. The freedom to design grows, with solutions that were impossible until yesterday.

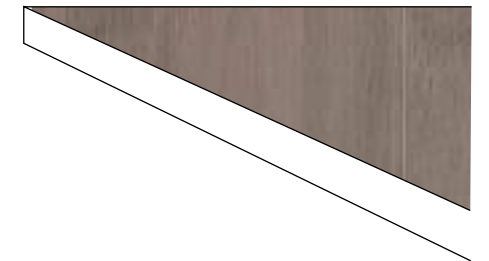

Des dalles si innovants et polyvalents qu'ils éliminent non seulement les frontières entre les surfaces dans l'architecture et l'ameublement mais aussi entre intérieur et extérieur. Une liberté de créer multipliée avec des solutions impossibles jusqu'à hier.

Diese Platten sind so innovativ und vielseitig, dass sie die Grenzen zwischen Oberflächen für die Architektur und die Einrichtung, zwischen Innen und Außen aufheben. So steigt die Gestaltungsfreiheit mit Lösungen, die gestern noch unmöglich erschienen.







Wall and floor
Roads Pearl Mind
Counter top
Roads Pearl Mind
Furniture
Alps Heart
Roads Pearl Mind





Wall and floor
Marmi Calacatta
Counter top
Marmi Calacatta
Furniture
Roads Dark Depth





Floor
Hi Lite Metal XXL
Grey Metal

Counter top
Hi Lite Metal XXL
Black Chrome

Furniture
Hi Lite Metal XXL
Black Chrome

Table
Marmi Gaudi Stone





Floor
Hi Lite Avenue XXL Plumb

Wall
Hi Lite Avenue XXL Plumb

**Kitchen countertop e
backsplash panel**
Marmi Extra White

Furniture
Hi Lite Avenue XXL Silver





Floor
Marmi Blue De Savoie
Wall
Marmi Bianco Lasa
Furniture
Marmi Bianco Lasa





Wall and floor
Onice Oro
Furniture
Roads Coffee Truth





— hospitality&wellness —

Wall
Onice Avorio
Furniture
Onice Grigio

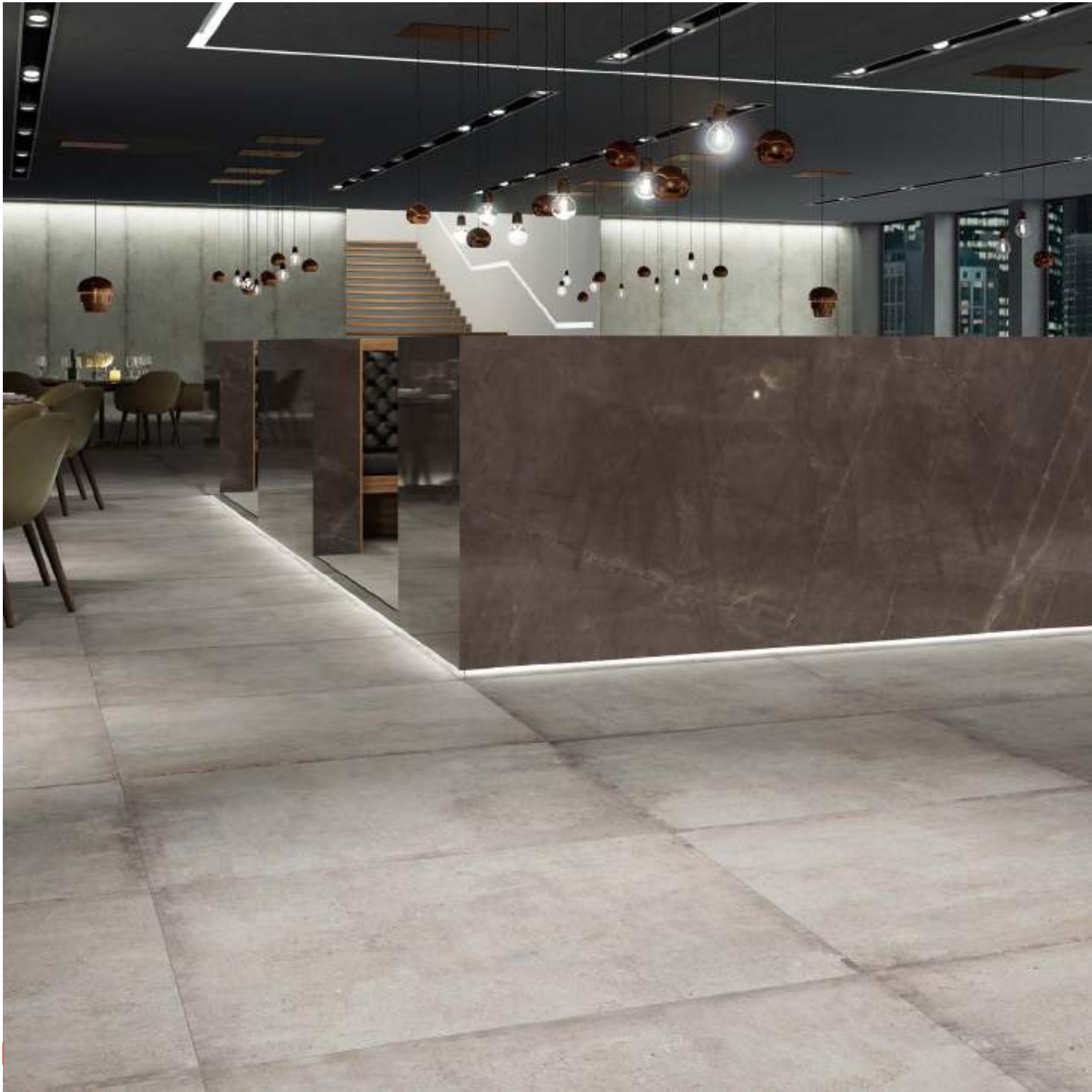



Floor
Citystone Pearl
Furniture
Marmi Gaudi Stone





Floor
Citystone Dove
Wall
Citystone Brown

Wall and floor
Marmi Arabescato Light
Furniture
Marmi Gaudi Stone







Wall
Marmi Statuario Light

Floor
Citystone Grey

Furniture
Marmi Statuario Light





hospitality&wellness —

Wall cladding
Corten
Floor
Limestone Moon

Wall and floor
Marmi Gaudi Stone

Vanity top
Marmi Arabescato

Furniture
Corten







Wall
Marmi Bianco Lasa

Floor
Marmi Bianco Lasa
Limestone Deep

Furniture
Marmi Bianco Lasa





Floor
Pietre Lavica Dark
Furniture
Travertino Classico

Wall
Marmi Eramosa
Hi Lite Avenue XXL Ivory

Floor
Marmi Eramosa

Door
Hi Lite Avenue XXL Ivory

Vanity top
Marmi Eramosa











Floor
Marmi Black Marquinia



Wall
Marmi Veined White



luxury home





Wall
Marmi Veined White
Marmi Black
Marquinia

Floor
Marmi Veined White

Table
Marmi Black
Marquinia





Wall
Marmi Statuario Light

Floor
Marmi Stone Grey

Fireplace and table
Marmi Statuario Light



indoor&outdoor furniture





indoor&outdoor furniture —

Floor
Marmi Gaudi Stone
Furniture
Marmi Statuario Light





Floor
Marmi Crema
Marfil Extra
**Fireplace
and table**
Marmi Eramosa





indoor&outdoor furniture

Floor
Iron Grey
Fireplace and table
Iron Black





Wall
Onice Avorio
Onice Verde
Floor
Onice Verde





Wall and floor

Iron Bronze

Door

Iron Bronze

Furniture

Hi Lite Metal XXL White Chrome





Floor
Marmi Portoro
Furniture
Onice Oro





Wall
Marmi Blue de Savoie

Floor
Marmi Blue de Savoie
Marmi Bianco Lasa
Roads Dark Depth

Furniture
Roads Dark Depth
Marmi Bianco Lasa





Wall and floor
Marmi Arabescato
Black Venato





Wall and floor
Marmi Eramosa
Onice Oro

Furniture
Marmi Eramosa
Onice Oro

Wall
Onice Oro
Onice Perla
Floor
Onice Perla
Vanity top
Maxfine Onice Oro







— wall cladding

Wall cladding
Marmi Veined White
Marmi Stone Grey





Wall
Iron Grey
Floor
Marmi Stone Grey



Wall cladding
Marmi Bianco Lasa
Limestone Ash
Floor
Limestone Ash

—
wall cladding





Marble inspiration

83



Iron inspiration

171





Stone inspiration

147



Design inspiration

179

Marble inspiration

- 83 **MARMI** VEINED WHITE
- 85 **MARMI** BLACK MARQUINIA
- 87 **MARMI** WHITE CALACATTA
- 89 **MARMI** STATUARIO LIGHT
- 93 **MARMI** ARABESCATO LIGHT
- 95 **MARMI** GAUDI STONE
- 97 **MARMI** STONE GREY
- 99 **MARMI** PORTORO
- 101 **MARMI** ESTREMOZ CREMA
- 103 **MARMI** CALACATTA
- 107 **MARMI** ALPS HEART
- 109 **MARMI** CREMA MARFIL EXTRA
- 111 **MARMI** ERAMOSA
- 113 **MARMI** THASSOS
- 115 **MARMI** BIANCO LASA
- 117 **MARMI** BIANCO VENATO EXTRA
- 121 **MARMI** ARABESCATO
- 125 **MARMI** EXTRA WHITE
- 129 **MARMI** BLUE DE SAVOIE
- 131 **MARMI** BLACK VENATO
- 133 **ONICE** AVORIO
- 135 **ONICE** GRIGIO
- 137 **ONICE** VERDE
- 139 **ONICE** PERLA
- 141 **ONICE** ORO
- 143 **TRAVERTINO** CLASSICO
- 145 **TRAVERTINO**

Stone inspiration

- 147 **CITYSTONE** DOVE
- 149 **CITYSTONE** BROWN
- 151 **CITYSTONE** PEARL
- 153 **CITYSTONE** GREY
- 155 **LIMESTONE** MOON
- 157 **LIMESTONE** ASH
- 159 **LIMESTONE** DEEP
- 161 **PIETRE** LAVICA PEARL
- 163 **PIETRE** LAVICA BEIGE
- 165 **PIETRE** LAVICA DARK
- 167 **PIETRE** LAVICA GREY
- 169 **PIETRE** LAVICA BLACK

Iron inspiration

- 171 **CORTEN**
- 173 **IRON** BRONZE
- 175 **IRON** BLACK
- 177 **IRON** GREY

Design inspiration

- 179 **ROADS** WHITE PURITY
- 181 **ROADS** SAND HEARTH
- 183 **ROADS** COFFEE TRUTH
- 185 **ROADS** PEARL MIND
- 187 **ROADS** GREY CALM
- 189 **ROADS** DARK DEPTH
- 191 **CHROMOCODE 3D** TITANIUM WHITE
- 193 **CHROMOCODE 3D** IVORY BLACK



VEINED WHITE MARM

New

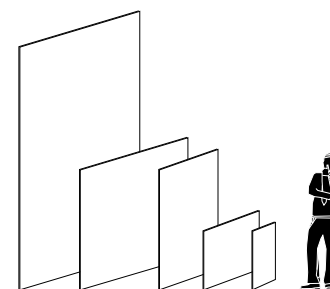

300x150 . 120"x60"

150x150 . 60"x60"

150x75 . 60"x30"

75x75 . 30"x30"

75x37,5 . 30"x15"

X 6 MM

LU LUCIDATO
E SQUADRATO

SY SILKY
E SQUADRATO



BLACK MARQUINIA MARMI

New

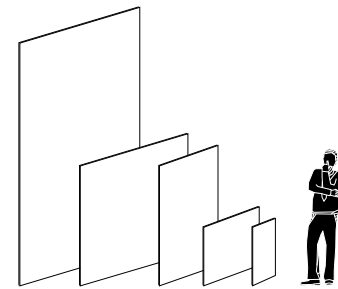

300x150 . 120"x60"

150x150 . 60"x60"

150x75 . 60"x30"

75x75 . 30"x30"

75x37,5 . 30"x15"

 6 MM

 LUCIDATO
E SQUADRATO

 SILKY
E SQUADRATO

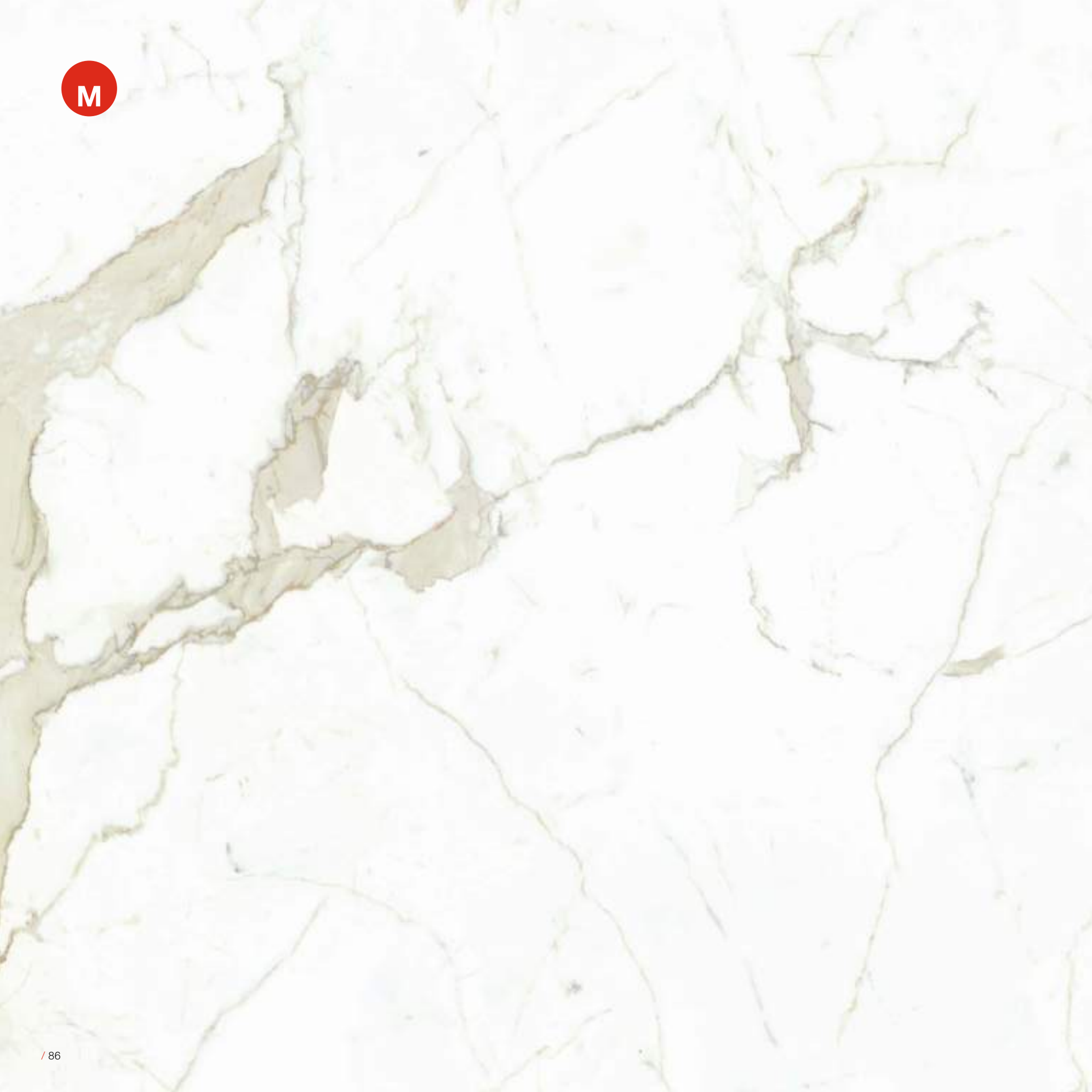

WHITE CALACATTA MARMI

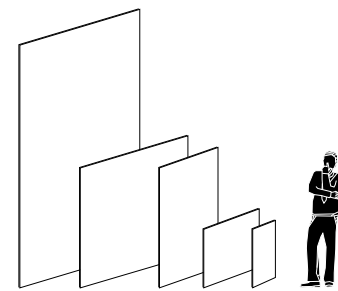

300x150 . 120"x60"

150x150 . 60"x60"

150x75 . 60"x30"

75x75 . 30"x30"

75x37,5 . 30"x15"

 6 MM

 LUCIDATO
E SQUADRATO

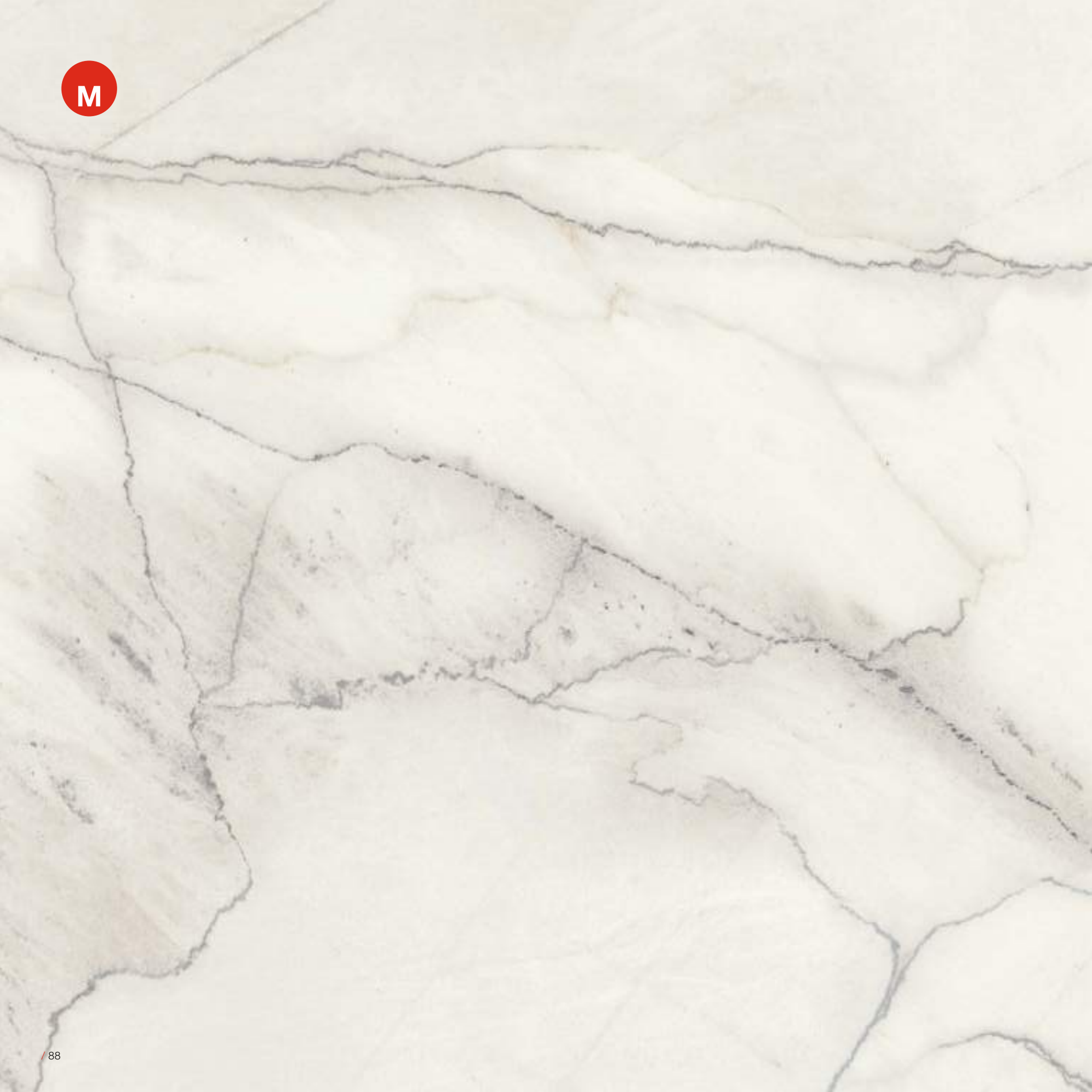

STATUARIO LIGHT MARMI

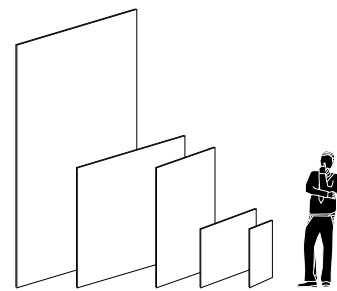
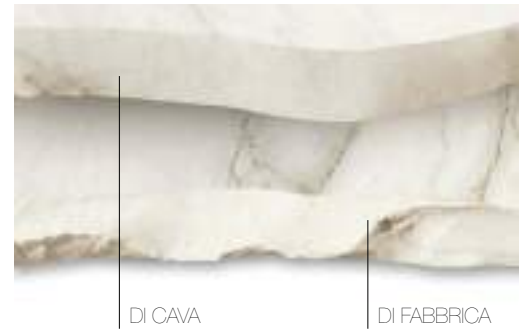

300x150 . 120"x60"

150x150 . 60"x60"

150x75 . 60"x30"

75x75 . 30"x30"

75x37,5 . 30"x15"

 6 MM

 LUCIDATO
E SQUADRATO

M



BLOCK A

BLOCK B

BLOCK B

BLOCK A

STATUARIO LIGHT MARMI

La mission di FMG è produrre materiali che rappresentino il massimo della bellezza, garantendo una disponibilità e una qualità che la pietra in natura non potrebbe offrire.

Block A e Block B sono due lastre che permettono di riprodurre l'effetto del marmo "a macchia aperta" con venatura speculare. È un effetto che in natura è decisamente raro e prezioso, perché richiede una speciale lavorazione, partendo da particolari blocchi selezionati. Questi prototipi di bellezza "ideale", finora riservati a edifici di lusso, sono oggi disponibili con continuità grazie all'avanguardia tecnologica MAXFINE.

IMPIEGO

Le lastre Block A-Block B possono essere posate a coppie, orientandole come in foto o capovolte. Sono utilizzabili anche con composizioni multiple, replicando il modulo più volte.

La mission de FMG est de produire des matériaux d'une beauté maximale tout en garantissant une disponibilité et une qualité que la pierre naturelle ne pourrait pas offrir.

Les deux carrelages grands formats Block A et Block B permettent de reproduire l'effet du marbre au veinage spéculaire dit « à livre ouvert ». Un effet particulièrement rare et précieux dans la nature étant donné qu'il exige une fabrication spéciale à partir de blocs sélectionnés. Ces prototypes d'une beauté « idéale », réservés jusqu'à maintenant aux édifices de luxe, sont aujourd'hui disponibles en permanence grâce à l'avant-garde technologique MAXFINE.

UTILISATION

Les carrelages grands formats Block A-Block B peuvent être posés deux à deux soit en les orientant comme sur la photo soit en les retournant. En répliquant le module plusieurs fois, ils peuvent aussi être utilisés dans des compositions multiples.

FMG's mission is to produce materials that are the tops in beauty, guaranteeing availability and quality such that stone, in nature, would be unable to offer.

Block A and Block B are two tiles that enable the effect of "book-matched" marble with mirror-image veining. This effect is definitely rare in nature and precious as it requires special processing, starting out from particular selected blocks. These prototypes of "ideal" beauty, set aside so far for luxury buildings, are now available on a continuous basis thanks to MAXFINE avant-garde technology.

USE

Block A and Block B tiles can be laid in pairs, positioning them as shown in the photograph or turned upside down. They can also be used with multiple compositions, replicating the module more than once.

Die Mission von FMG ist es Materialien herzustellen, die ein Maximum an Schönheit mit der Verfügbarkeit und einer Qualität kombinieren, die der Naturstein niemals bieten kann.

Block A und Block B sind zwei Platten, mit denen man den Effekt des Marmors "a macchia aperta" („offenes Buch“) mit spiegelgleicher Maserung reproduzieren kann. Es handelt sich um einen Effekt, der in der Natur sehr selten und wertvoll ist, denn hier bedarf es einer speziellen Verarbeitung, bei der von besonderen und ausgewählten Blöcken ausgegangen wird. Diese Prototypen der "idealen" Schönheit, die bisher den Luxusbauten vorbehalten war, gibt es heute – dank des technologischen Fortschritts von MAXIFINE - kontinuierlich.

VERWENDUNG

Die Platten Block A-Block B können paarweise verlegt werden, indem sie wie im Bild ausgerichtet werden oder aber auch auf dem Kopf. Sie lassen sich auch bei Mehrfachkompositionen im Quadrat oder in der Reihe benutzen, wobei das Modul mehrere Male wiederholt wird.

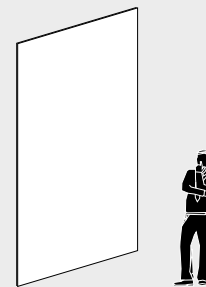

Disponibile a richiesta_Available on demand

300x150 . 120"x60"

BLOCK A

BLOCK B



6 MM



LUCIDATO
E SQUADRATO



ARABESCATO LIGHT MARMI



DI CAVA

DI FABBRICA

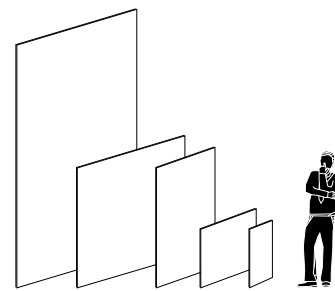

300x150 . 120"x60"

150x150 . 60"x60"

150x75 . 60"x30"

75x75 . 30"x30"

75x37,5 . 30"x15"

 6 MM

 LUCIDATO
E SQUADRATO

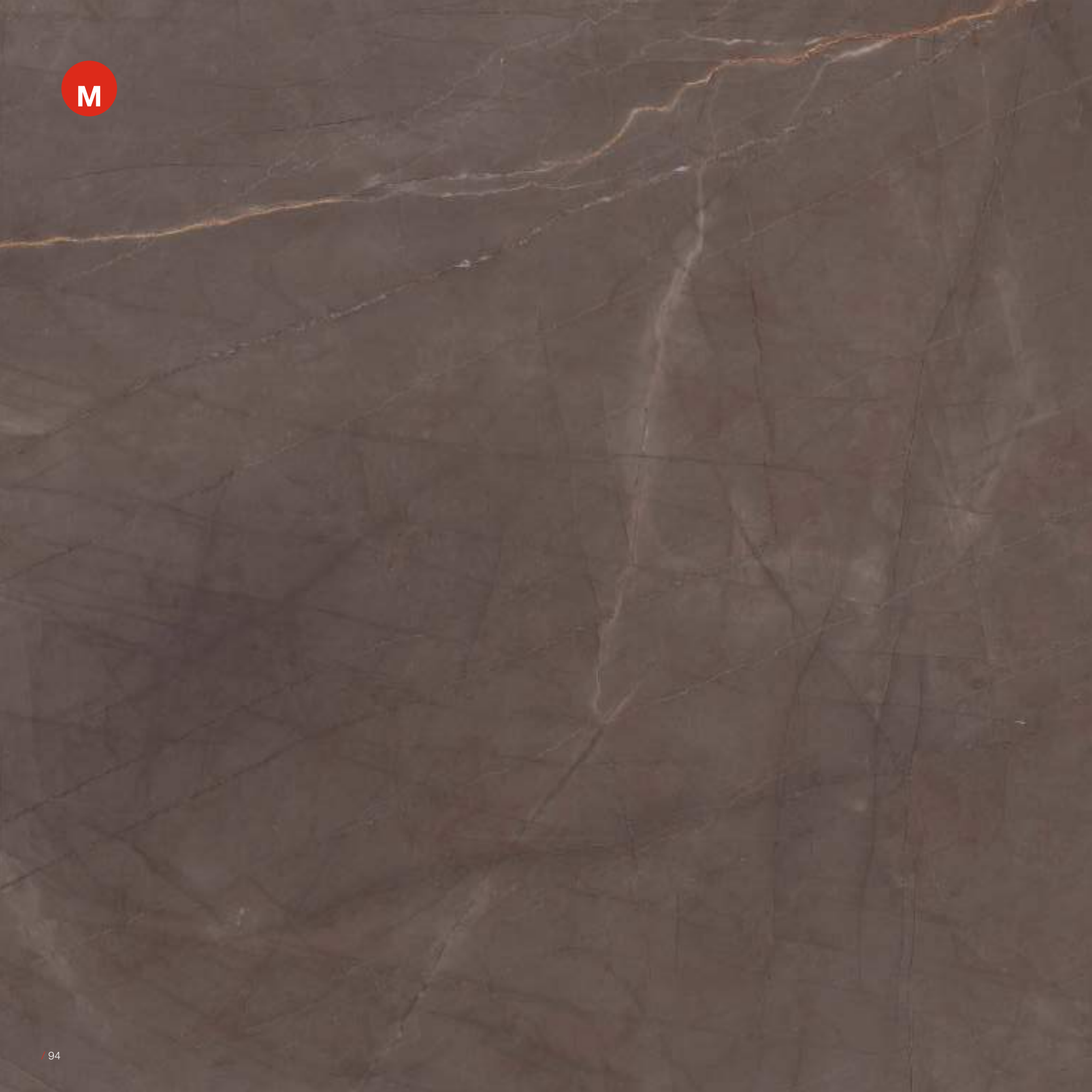

GAUDI STONE MARMI



DI CAVA

DI FABBRICA

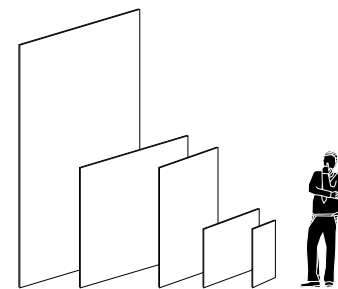

300x150 . 120"x60"

150x150 . 60"x60"

150x75 . 60"x30"

75x75 . 30"x30"

75x37,5 . 30"x15"

 6 MM

 LUCIDATO
E SQUADRATO

 PRELUCIDATO
E SQUADRATO

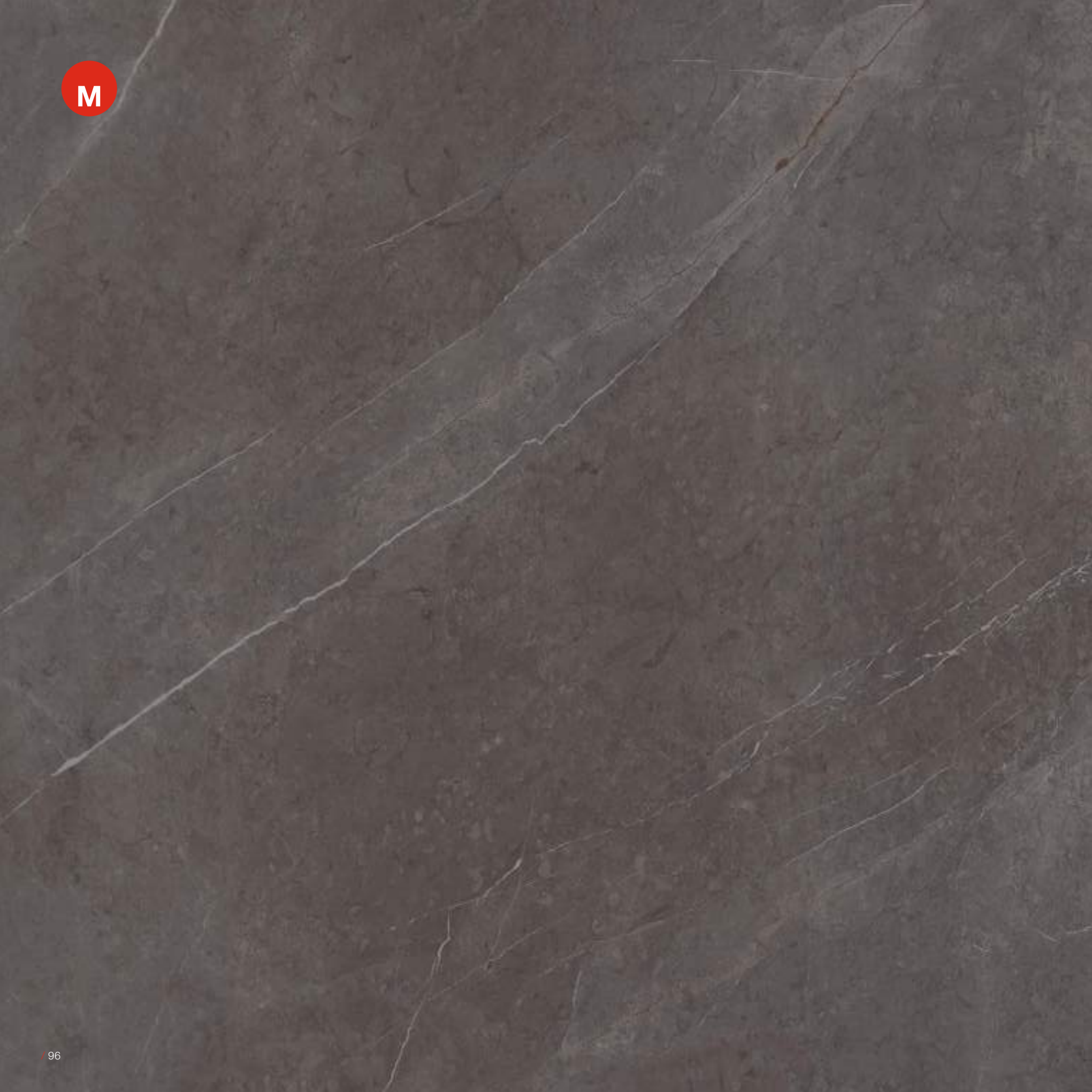

STONE GREY MARMI

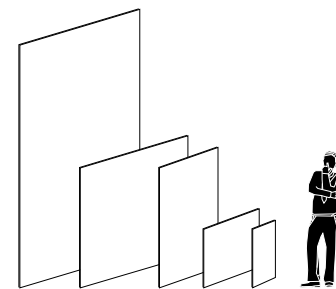
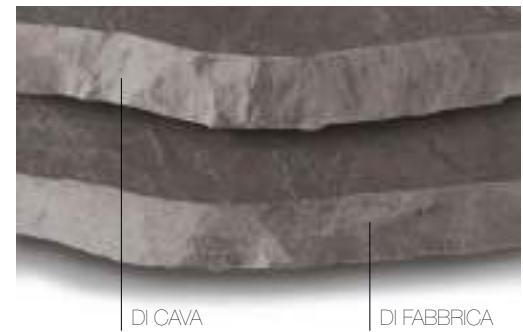

300x150 . 120"x60"

150x150 . 60"x60"

150x75 . 60"x30"

75x75 . 30"x30"

75x37,5 . 30"x15"

X 6 MM

LU LUCIDATO
E SQUADRATO

PL PRELUCIDATO
E SQUADRATO



PORTORO MARMI



DI CAVA

DI FABBRICA

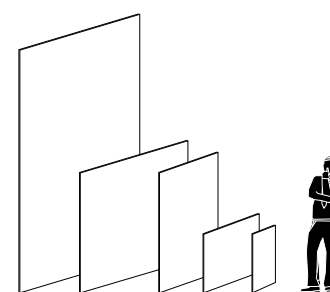

300x150 . 120"x60"

150x150 . 60"x60"

150x75 . 60"x30"

75x75 . 30"x30"

75x37,5 . 30"x15"

 6 MM

 LUCIDATO
E SQUADRATO



ESTREMOZ CREMA MARMI

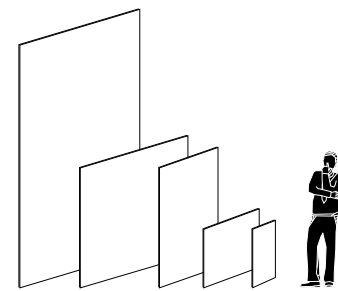

300x150 . 120"x60"

150x150 . 60"x60"

150x75 . 60"x30"

75x75 . 30"x30"

75x37,5 . 30"x15"

 6 MM

 LUCIDATO
E SQUADRATO

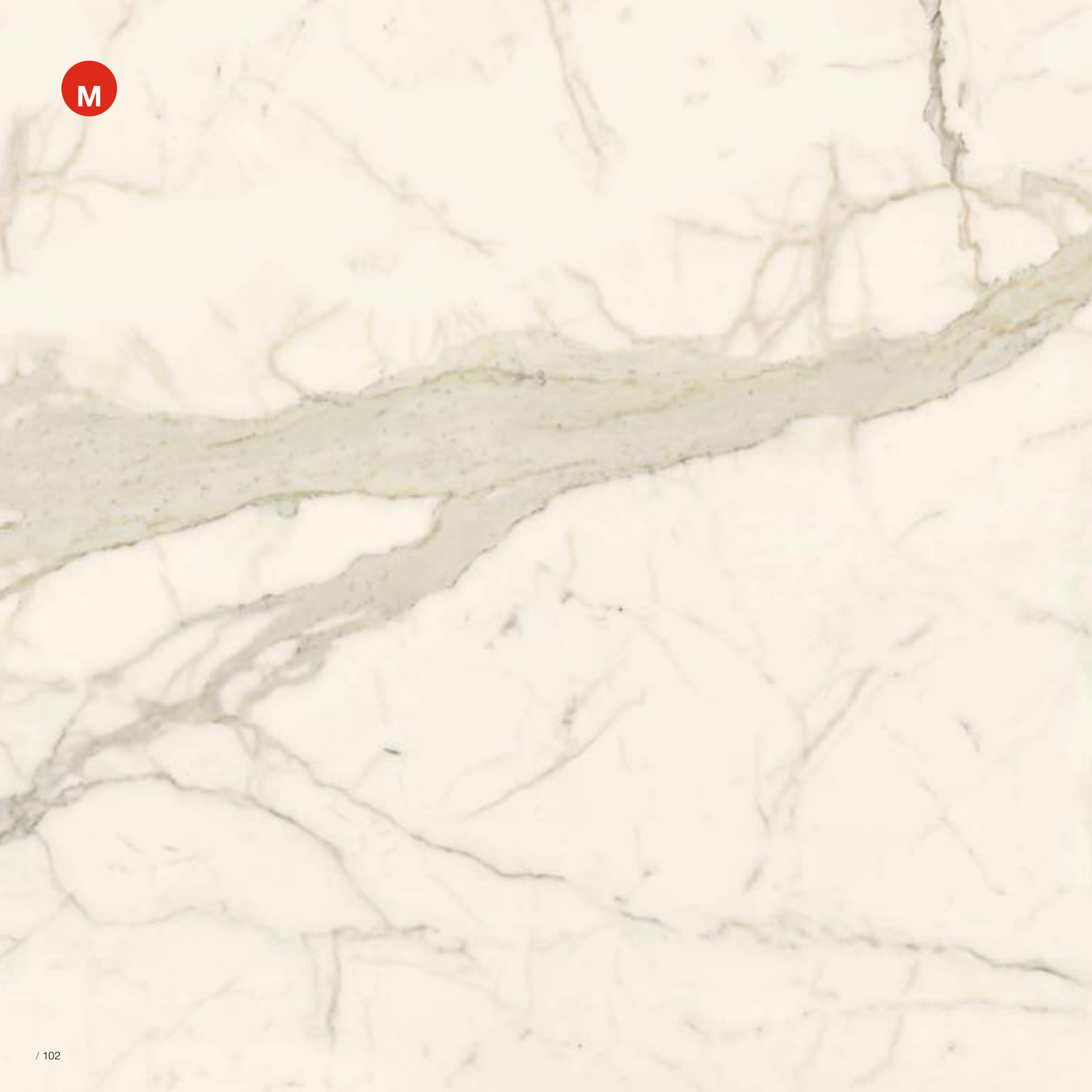

CALACATTA MARMI

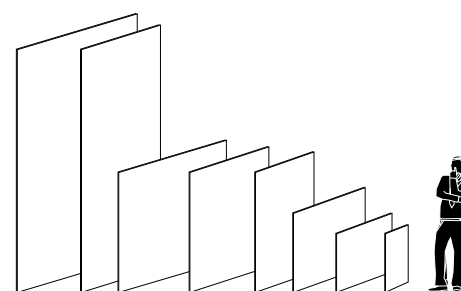

300x150 . 120"x60"

300x100 . 120"x40"

150x150 . 60"x60"

150x100 . 60"x40"

150x75 . 60"x30"

100x100 . 40"x40"

75x75 . 30"x30"

75x37,5 . 30"x15"

 6 MM

 LUCIDATO
E SQUADRATO

 PRELUCIDATO
E SQUADRATO

M





La mission di FMG è produrre materiali che rappresentino il massimo della bellezza, garantendo una disponibilità e una qualità che la pietra in natura non potrebbe offrire.

Block A e Block B sono due lastre che permettono di riprodurre l'effetto del marmo "a macchia aperta" con venatura speculare. È un effetto che in natura è decisamente raro e prezioso, perché richiede una speciale lavorazione, partendo da particolari blocchi selezionati.

Questi prototipi di bellezza "ideale", finora riservati a edifici di lusso, sono oggi disponibili con continuità grazie all'avanguardia tecnologica MAXFINE.

IMPIEGO

Le lastre Block A-Block B possono essere posate a coppie, orientandole come in foto o capovolte. Sono utilizzabili anche con composizioni multiple, replicando il modulo più volte.

La mission de FMG est de produire des matériaux d'une beauté maximale tout en garantissant une disponibilité et une qualité que la pierre naturelle ne pourrait pas offrir.

Les deux carrelages grands formats Block A et Block B permettent de reproduire l'effet du marbre au veinage spéculaire dit « à livre ouvert ». Un effet particulièrement rare et précieux dans la nature étant donné qu'il exige une fabrication spéciale à partir de blocs sélectionnés.

Ces prototypes d'une beauté « idéale », réservés jusqu'à maintenant aux édifices de luxe, sont aujourd'hui disponibles en permanence grâce à l'avant-garde technologique MAXFINE.

UTILISATION

Les carrelages grands formats Block A-Block B peuvent être posés deux à deux soit en les orientant comme sur la photo soit en les retournant. En répliquant le module plusieurs fois, ils peuvent aussi être utilisés dans des compositions multiples.

FMG's mission is to produce materials that are the tops in beauty, guaranteeing availability and quality such that stone, in nature, would be unable to offer.

Block A and Block B are two tiles that enable the effect of "book-matched" marble with mirror-image veining. This effect is definitely rare in nature and precious as it requires special processing, starting out from particular selected blocks.

These prototypes of "ideal" beauty, set aside so far for luxury buildings, are now available on a continuous basis thanks to MAXFINE avant-garde technology.

USE

Block A and Block B tiles can be laid in pairs, positioning them as shown in the photograph or turned upside down. They can also be used with multiple compositions, replicating the module more than once.

Die Mission von FMG ist es Materialien herzustellen, die ein Maximum an Schönheit mit der Verfügbarkeit und einer Qualität kombinieren, die der Naturstein niemals bieten kann.

Block A und Block B sind zwei Platten, mit denen man den Effekt des Marmors "a macchia aperta" („offenes Buch“) mit spiegelgleicher Maserung reproduzieren kann. Es handelt sich um einen Effekt, der in der Natur sehr selten und wertvoll ist, denn hier bedarf es einer speziellen Verarbeitung, bei der von besonderen und ausgewählten Blöcken ausgegangen wird. Diese Prototypen der "idealen" Schönheit, die bisher den Luxusbauten vorbehalten war, gibt es heute – dank des technologischen Fortschritts von MAXIFINE - kontinuierlich.

VERWENDUNG

Die Platten Block A-Block B können paarweise verlegt werden, indem sie wie im Bild ausgerichtet werden oder aber auch auf dem Kopf. Sie lassen sich auch bei Mehrfachkompositionen im Quadrat oder in der Reihe benutzen, wobei das Modul mehrere Male wiederholt wird.

CALACATTA MARMI

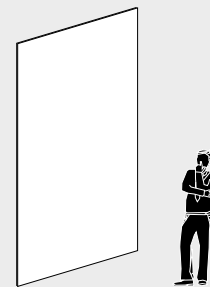

300x150 . 120"x60"

BLOCK A

BLOCK B

 6 MM

 LUCIDATO
E SQUADRATO

 PRELUCIDATO
E SQUADRATO

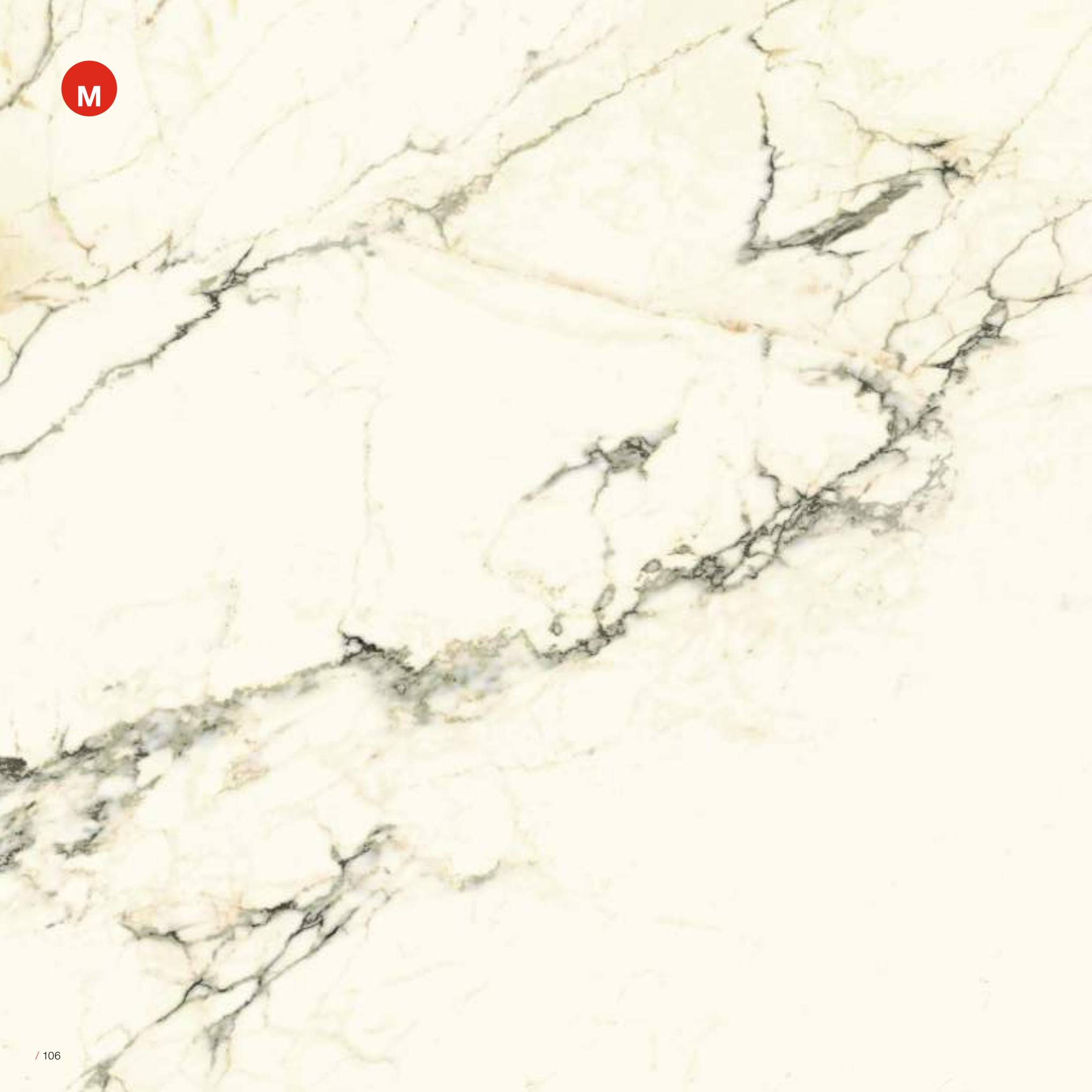

ALPS HEART MARMI

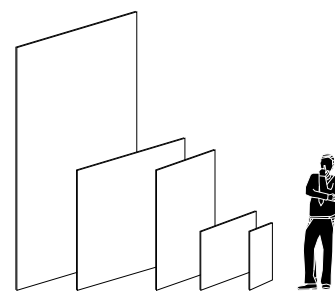
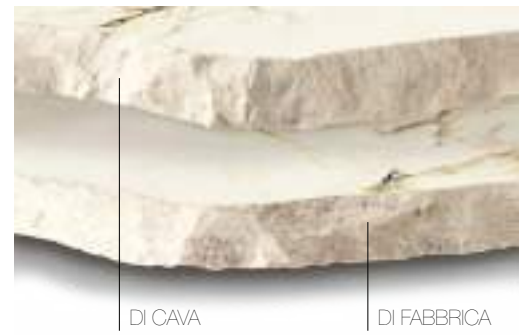

300x150 . 120"x60"

150x150 . 60"x60"

150x75 . 60"x30"

75x75 . 30"x30"

75x37,5 . 30"x15"

 6 MM

 LUCIDATO
E SQUADRATO



CREMA MARFIL EXTRA MARM



DI CAVA

DI FABBRICA

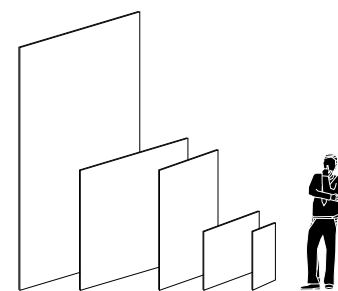

300x150 . 120"x60"

150x150 . 60"x60"

150x75 . 60"x30"

75x75 . 30"x30"

75x37,5 . 30"x15"

X 6 MM

LU LUCIDATO
E SQUADRATO

PL PRELUCIDATO
E SQUADRATO



ERAMOSA MARMI

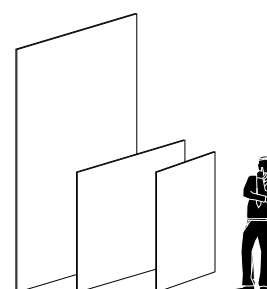

300x150 . 120"x60"

150x150 . 60"x60"

150x75 . 60"x30"

 6 MM

 LUCIDATO
E SQUADRATO



THASSOS MARMI

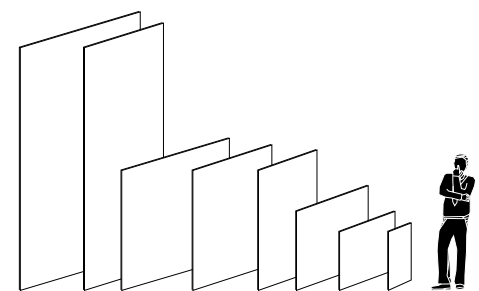
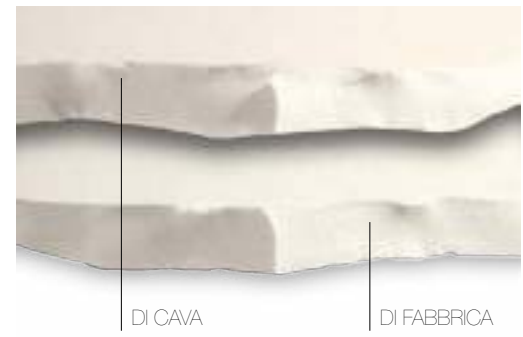

300x150 . 120"x60"

300x100 . 120"x40"

150x150 . 60"x60"

150x100 . 60"x40"

150x75 . 60"x30"

100x100 . 40"x40"

75x75 . 30"x30"

75x37,5 . 30"x15"

 6 MM

 LUCIDATO
E SQUADRATO

 PRELUCIDATO
E SQUADRATO



BIANCO LASA MARMI

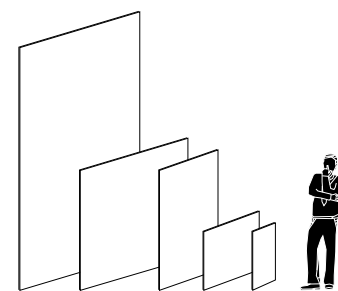
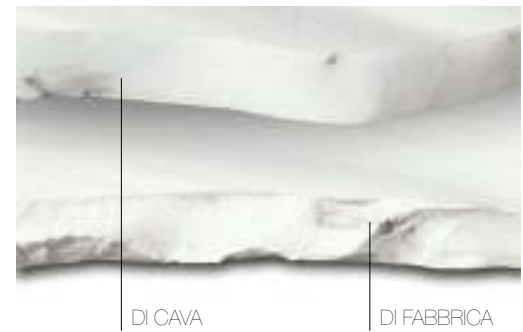

300x150 . 120"x60"

150x150 . 60"x60"

150x75 . 60"x30"

75x75 . 30"x30"

75x37,5 . 30"x15"

X 6 MM

LU LUCIDATO
E SQUADRATO

PL PRELUCIDATO
E SQUADRATO



BIANCO VENATO EXTRA MARM

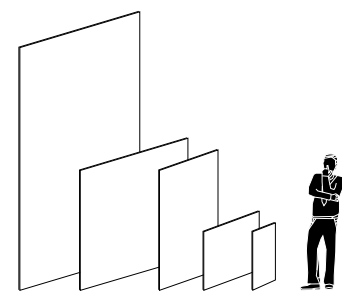

300x150 . 120"x60"

150x150 . 60"x60"

150x75 . 60"x30"

75x75 . 30"x30"

75x37,5 . 30"x15"

X 6 MM

LU LUCIDATO
E SQUADRATO

PL PRELUCIDATO
E SQUADRATO

M





La mission di FMG è produrre materiali che rappresentino il massimo della bellezza, garantendo una disponibilità e una qualità che la pietra in natura non potrebbe offrire.

Block A e Block B sono due lastre che permettono di riprodurre l'effetto del marmo "a macchia aperta" con venatura speculare. È un effetto che in natura è decisamente raro e prezioso, perché richiede una speciale lavorazione, partendo da particolari blocchi selezionati.

Questi prototipi di bellezza "ideale", finora riservati a edifici di lusso, sono oggi disponibili con continuità grazie all'avanguardia tecnologica MAXFINE.

IMPIEGO

Le lastre Block A-Block B possono essere posate a coppie, orientandole come in foto o capovolte. Sono utilizzabili anche con composizioni multiple, replicando il modulo più volte.

La mission de FMG est de produire des matériaux d'une beauté maximale tout en garantissant une disponibilité et une qualité que la pierre naturelle ne pourrait pas offrir.

Les deux carrelages grands formats Block A et Block B permettent de reproduire l'effet du marbre au veinage spéculaire dit « à livre ouvert ». Un effet particulièrement rare et précieux dans la nature étant donné qu'il exige une fabrication spéciale à partir de blocs sélectionnés.

Ces prototypes d'une beauté « idéale », réservés jusqu'à maintenant aux édifices de luxe, sont aujourd'hui disponibles en permanence grâce à l'avant-garde technologique MAXFINE.

UTILISATION

Les carrelages grands formats Block A-Block B peuvent être posés deux à deux soit en les orientant comme sur la photo soit en les retournant. En répliquant le module plusieurs fois, ils peuvent aussi être utilisés dans des compositions multiples.

FMG's mission is to produce materials that are the tops in beauty, guaranteeing availability and quality such that stone, in nature, would be unable to offer.

Block A and Block B are two tiles that enable the effect of "book-matched" marble with mirror-image veining. This effect is definitely rare in nature and precious as it requires special processing, starting out from particular selected blocks.

These prototypes of "ideal" beauty, set aside so far for luxury buildings, are now available on a continuous basis thanks to MAXFINE avant-garde technology.

USE

Block A and Block B tiles can be laid in pairs, positioning them as shown in the photograph or turned upside down. They can also be used with multiple compositions, replicating the module more than once.

Die Mission von FMG ist es Materialien herzustellen, die ein Maximum an Schönheit mit der Verfügbarkeit und einer Qualität kombinieren, die der Naturstein niemals bieten kann.

Block A und Block B sind zwei Platten, mit denen man den Effekt des Marmors "a macchia aperta" („offenes Buch“) mit spiegelgleicher Maserung reproduzieren kann. Es handelt sich um einen Effekt, der in der Natur sehr selten und wertvoll ist, denn hier bedarf es einer speziellen Verarbeitung, bei der von besonderen und ausgewählten Blöcken ausgegangen wird. Diese Prototypen der "idealen" Schönheit, die bisher den Luxusbauten vorbehalten war, gibt es heute – dank des technologischen Fortschritts von MAXIFINE - kontinuierlich.

VERWENDUNG

Die Platten Block A-Block B können paarweise verlegt werden, indem sie wie im Bild ausgerichtet werden oder aber auch auf dem Kopf. Sie lassen sich auch bei Mehrfachkompositionen im Quadrat oder in der Reihe benutzen, wobei das Modul mehrere Male wiederholt wird.

BIANCO VENATO EXTRA MARM

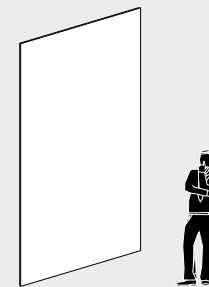

300x150 . 120"x60"

BLOCK A

BLOCK B

 6 MM

 LUCIDATO
E SQUADRATO

 PRELUCIDATO
E SQUADRATO

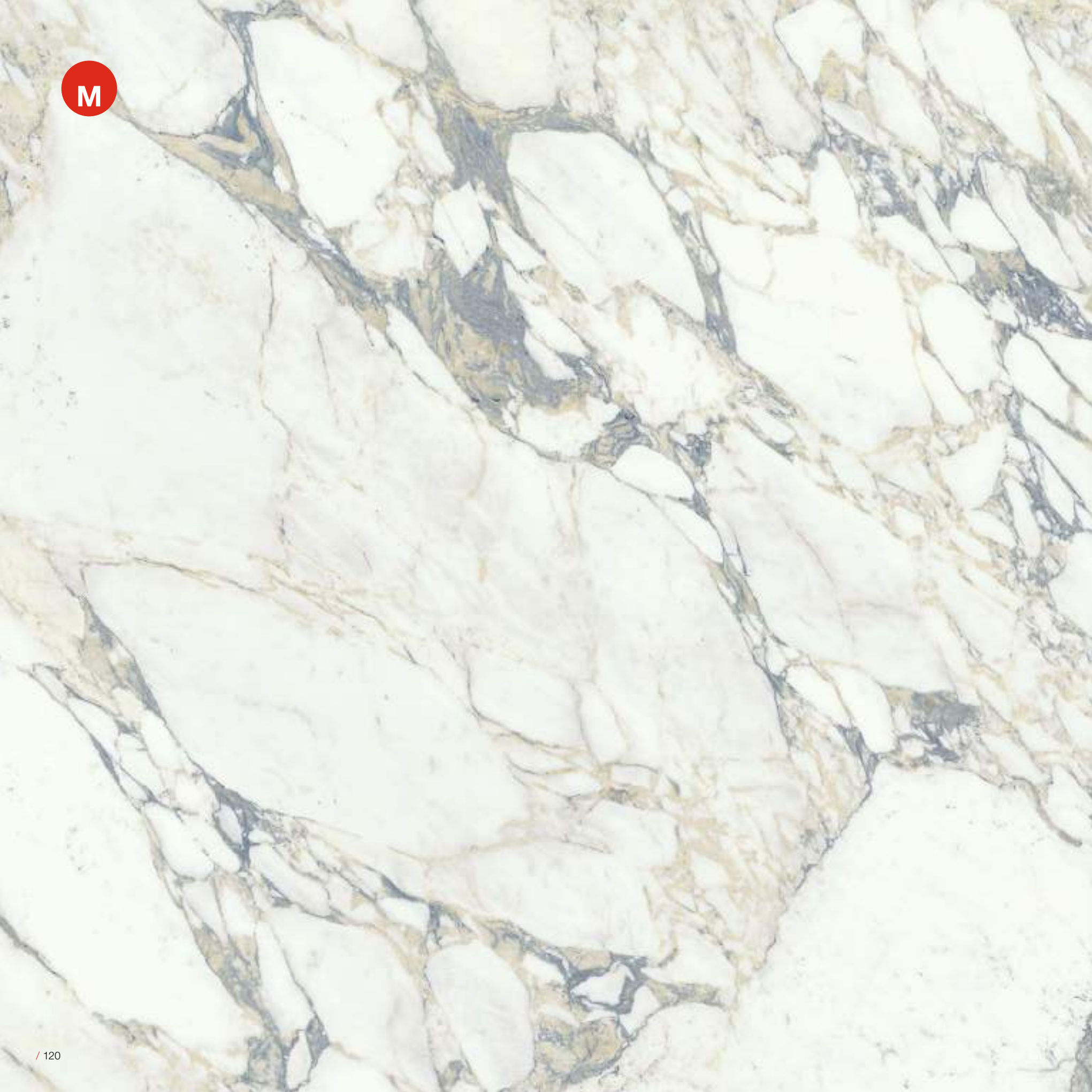

ARABESCATO MARMI

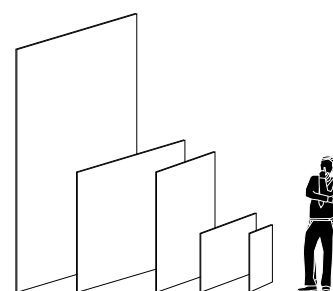

300x150 . 120"x60"

150x150 . 60"x60"

150x75 . 60"x30"

75x75 . 30"x30"

75x37,5 . 30"x15"

X 6 MM

LU LUCIDATO
E SQUADRATO

PL PRELUCIDATO
E SQUADRATO

M





La mission di FMG è produrre materiali che rappresentino il massimo della bellezza, garantendo una disponibilità e una qualità che la pietra in natura non potrebbe offrire.

Block A e Block B sono due lastre che permettono di riprodurre l'effetto del marmo "a macchia aperta" con venatura speculare. È un effetto che in natura è decisamente raro e prezioso, perché richiede una speciale lavorazione, partendo da particolari blocchi selezionati.

Questi prototipi di bellezza "ideale", finora riservati a edifici di lusso, sono oggi disponibili con continuità grazie all'avanguardia tecnologica MAXFINE.

IMPIEGO

Le lastre Block A-Block B possono essere posate a coppie, orientandole come in foto o capovolte. Sono utilizzabili anche con composizioni multiple, replicando il modulo più volte.

La mission de FMG est de produire des matériaux d'une beauté maximale tout en garantissant une disponibilité et une qualité que la pierre naturelle ne pourrait pas offrir.

Les deux carrelages grands formats Block A et Block B permettent de reproduire l'effet du marbre au veinage spéculaire dit « à livre ouvert ». Un effet particulièrement rare et précieux dans la nature étant donné qu'il exige une fabrication spéciale à partir de blocs sélectionnés.

Ces prototypes d'une beauté « idéale », réservés jusqu'à maintenant aux édifices de luxe, sont aujourd'hui disponibles en permanence grâce à l'avant-garde technologique MAXFINE.

UTILISATION

Les carrelages grands formats Block A-Block B peuvent être posés deux à deux soit en les orientant comme sur la photo soit en les retournant. En répliquant le module plusieurs fois, ils peuvent aussi être utilisés dans des compositions multiples.

FMG's mission is to produce materials that are the tops in beauty, guaranteeing availability and quality such that stone, in nature, would be unable to offer.

Block A and Block B are two tiles that enable the effect of "book-matched" marble with mirror-image veining. This effect is definitely rare in nature and precious as it requires special processing, starting out from particular selected blocks.

These prototypes of "ideal" beauty, set aside so far for luxury buildings, are now available on a continuous basis thanks to MAXFINE avant-garde technology.

USE

Block A and Block B tiles can be laid in pairs, positioning them as shown in the photograph or turned upside down. They can also be used with multiple compositions, replicating the module more than once.

Die Mission von FMG ist es Materialien herzustellen, die ein Maximum an Schönheit mit der Verfügbarkeit und einer Qualität kombinieren, die der Naturstein niemals bieten kann.

Block A und Block B sind zwei Platten, mit denen man den Effekt des Marmors "a macchia aperta" („offenes Buch“) mit spiegelgleicher Maserung reproduzieren kann. Es handelt sich um einen Effekt, der in der Natur sehr selten und wertvoll ist, denn hier bedarf es einer speziellen Verarbeitung, bei der von besonderen und ausgewählten Blöcken ausgegangen wird. Diese Prototypen der "idealen" Schönheit, die bisher den Luxusbauten vorbehalten war, gibt es heute – dank des technologischen Fortschritts von MAXIFINE - kontinuierlich.

VERWENDUNG

Die Platten Block A-Block B können paarweise verlegt werden, indem sie wie im Bild ausgerichtet werden oder aber auch auf dem Kopf. Sie lassen sich auch bei Mehrfachkompositionen im Quadrat oder in der Reihe benutzen, wobei das Modul mehrere Male wiederholt wird.

ARABESCATO MARMI

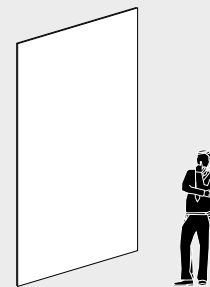

300x150 . 120"x60"

BLOCK A

BLOCK B

 6 MM

 LUCIDATO
E SQUADRATO

 PRELUCIDATO
E SQUADRATO

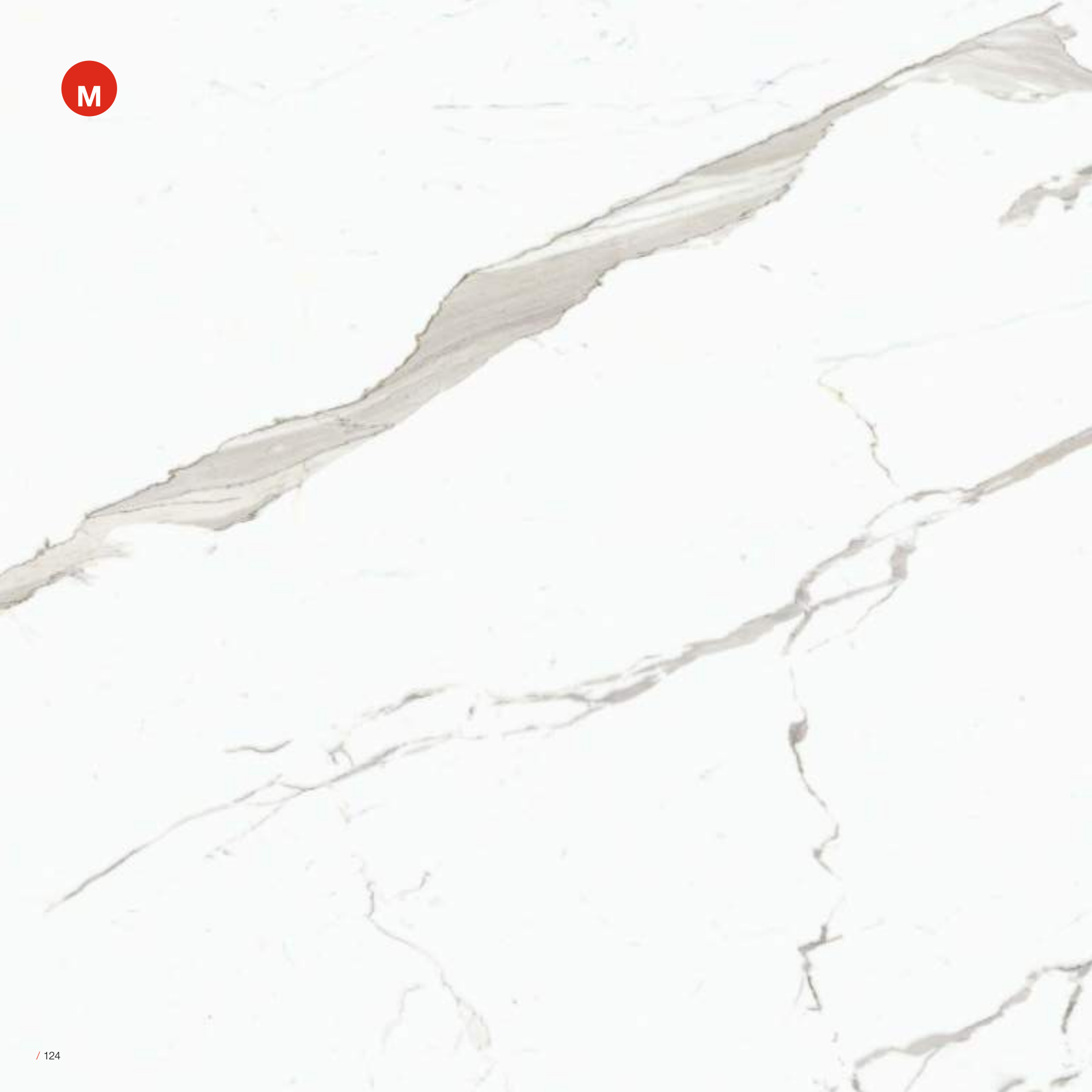

EXTRA WHITE MARMI

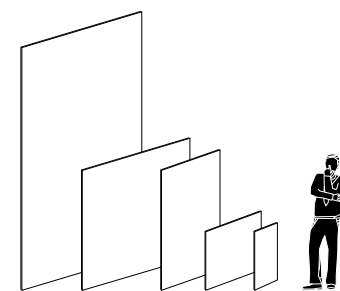
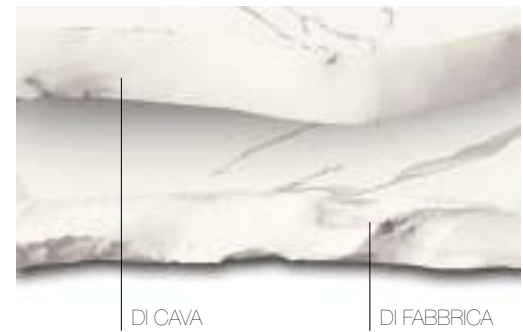

300x150 . 120"x60"

150x150 . 60"x60"

150x75 . 60"x30"

75x75 . 30"x30"

75x37,5 . 30"x15"

X 6 MM

LU LUCIDATO
E SQUADRATO

PL PRELUCIDATO
E SQUADRATO





La mission di FMG è produrre materiali che rappresentino il massimo della bellezza, garantendo una disponibilità e una qualità che la pietra in natura non potrebbe offrire.

Block A e Block B sono due lastre che permettono di riprodurre l'effetto del marmo "a macchia aperta" con venatura speculare. È un effetto che in natura è decisamente raro e prezioso, perché richiede una speciale lavorazione, partendo da particolari blocchi selezionati.

Questi prototipi di bellezza "ideale", finora riservati a edifici di lusso, sono oggi disponibili con continuità grazie all'avanguardia tecnologica MAXFINE.

IMPIEGO

Le lastre Block A-Block B possono essere posate a coppie, orientandole come in foto o capovolte. Sono utilizzabili anche con composizioni multiple, replicando il modulo più volte.

La mission de FMG est de produire des matériaux d'une beauté maximale tout en garantissant une disponibilité et une qualité que la pierre naturelle ne pourrait pas offrir.

Les deux carrelages grands formats Block A et Block B permettent de reproduire l'effet du marbre au veinage spéculaire dit « à livre ouvert ». Un effet particulièrement rare et précieux dans la nature étant donné qu'il exige une fabrication spéciale à partir de blocs sélectionnés.

Ces prototypes d'une beauté « idéale », réservés jusqu'à maintenant aux édifices de luxe, sont aujourd'hui disponibles en permanence grâce à l'avant-garde technologique MAXFINE.

UTILISATION

Les carrelages grands formats Block A-Block B peuvent être posés deux à deux soit en les orientant comme sur la photo soit en les retournant. En répliquant le module plusieurs fois, ils peuvent aussi être utilisés dans des compositions multiples.

FMG's mission is to produce materials that are the tops in beauty, guaranteeing availability and quality such that stone, in nature, would be unable to offer.

Block A and Block B are two tiles that enable the effect of "book-matched" marble with mirror-image veining. This effect is definitely rare in nature and precious as it requires special processing, starting out from particular selected blocks.

These prototypes of "ideal" beauty, set aside so far for luxury buildings, are now available on a continuous basis thanks to MAXFINE avant-garde technology.

USE

Block A and Block B tiles can be laid in pairs, positioning them as shown in the photograph or turned upside down. They can also be used with multiple compositions, replicating the module more than once.

Die Mission von FMG ist es Materialien herzustellen, die ein Maximum an Schönheit mit der Verfügbarkeit und einer Qualität kombinieren, die der Naturstein niemals bieten kann.

Block A und Block B sind zwei Platten, mit denen man den Effekt des Marmors "a macchia aperta" („offenes Buch“) mit spiegelgleicher Maserung reproduzieren kann. Es handelt sich um einen Effekt, der in der Natur sehr selten und wertvoll ist, denn hier bedarf es einer speziellen Verarbeitung, bei der von besonderen und ausgewählten Blöcken ausgegangen wird. Diese Prototypen der "idealen" Schönheit, die bisher den Luxusbauten vorbehalten war, gibt es heute – dank des technologischen Fortschritts von MAXIFINE - kontinuierlich.

VERWENDUNG

Die Platten Block A-Block B können paarweise verlegt werden, indem sie wie im Bild ausgerichtet werden oder aber auch auf dem Kopf. Sie lassen sich auch bei Mehrfachkompositionen im Quadrat oder in der Reihe benutzen, wobei das Modul mehrere Male wiederholt wird.

EXTRA WHITE MARMI

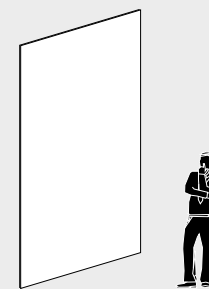

300x150 . 120"x60"

BLOCK A

BLOCK B

 6 MM

 LUCIDATO
E SQUADRATO

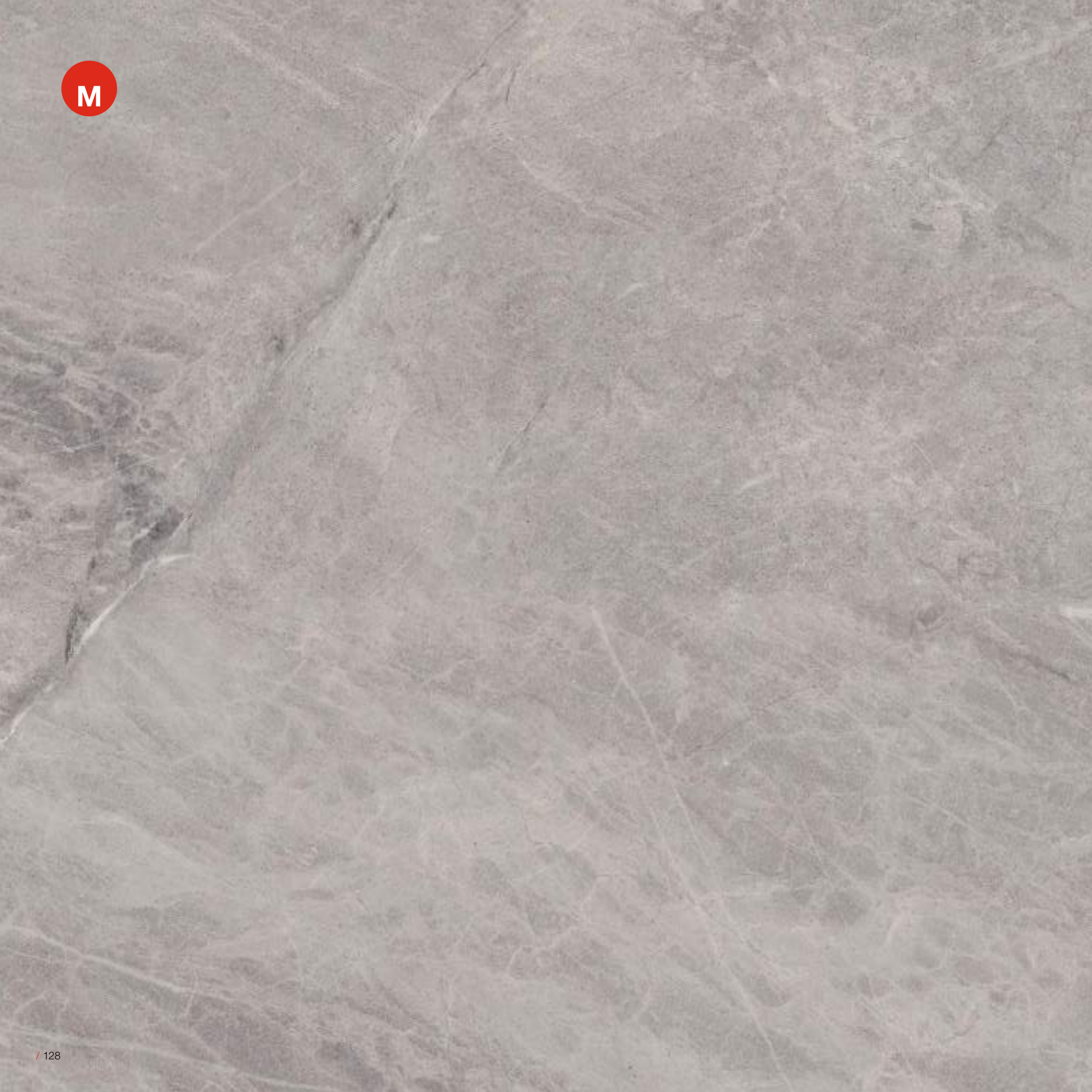

BLUE DE SAVOIE MARMI

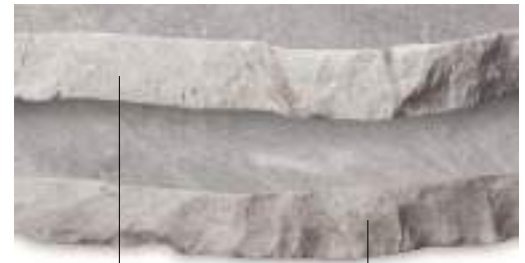

DI CAVA

DI FABBRICA

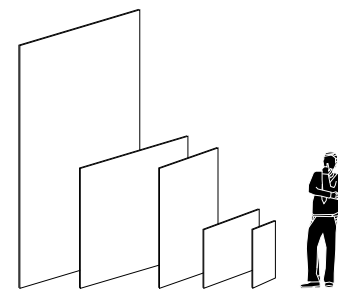

300x150 . 120"x60"

150x150 . 60"x60"

150x75 . 60"x30"

75x75 . 30"x30"

75x37,5 . 30"x15"

 6 MM

 LUCIDATO
E SQUADRATO

 PRELUCIDATO
E SQUADRATO



BLACK VENATO MARMI



DI CAVA

DI FABBRICA

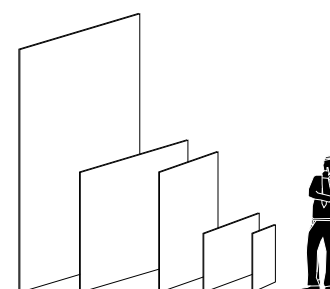

300x150 . 120"x60"

150x150 . 60"x60"

150x75 . 60"x30"

75x75 . 30"x30"

75x37,5 . 30"x15"

 6 MM

 LUCIDATO
E SQUADRATO



ONICE AVORIO

ONICE

New

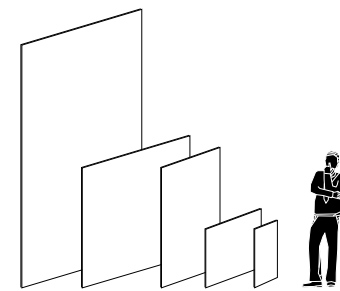

300x150 . 120"x60"

150x150 . 60"x60"

150x75 . 60"x30"

75x75 . 30"x30"

75x37,5 . 30"x15"

X 6 MM

LU LUCIDATO
E SQUADRATO

SY SILKY
E SQUADRATO

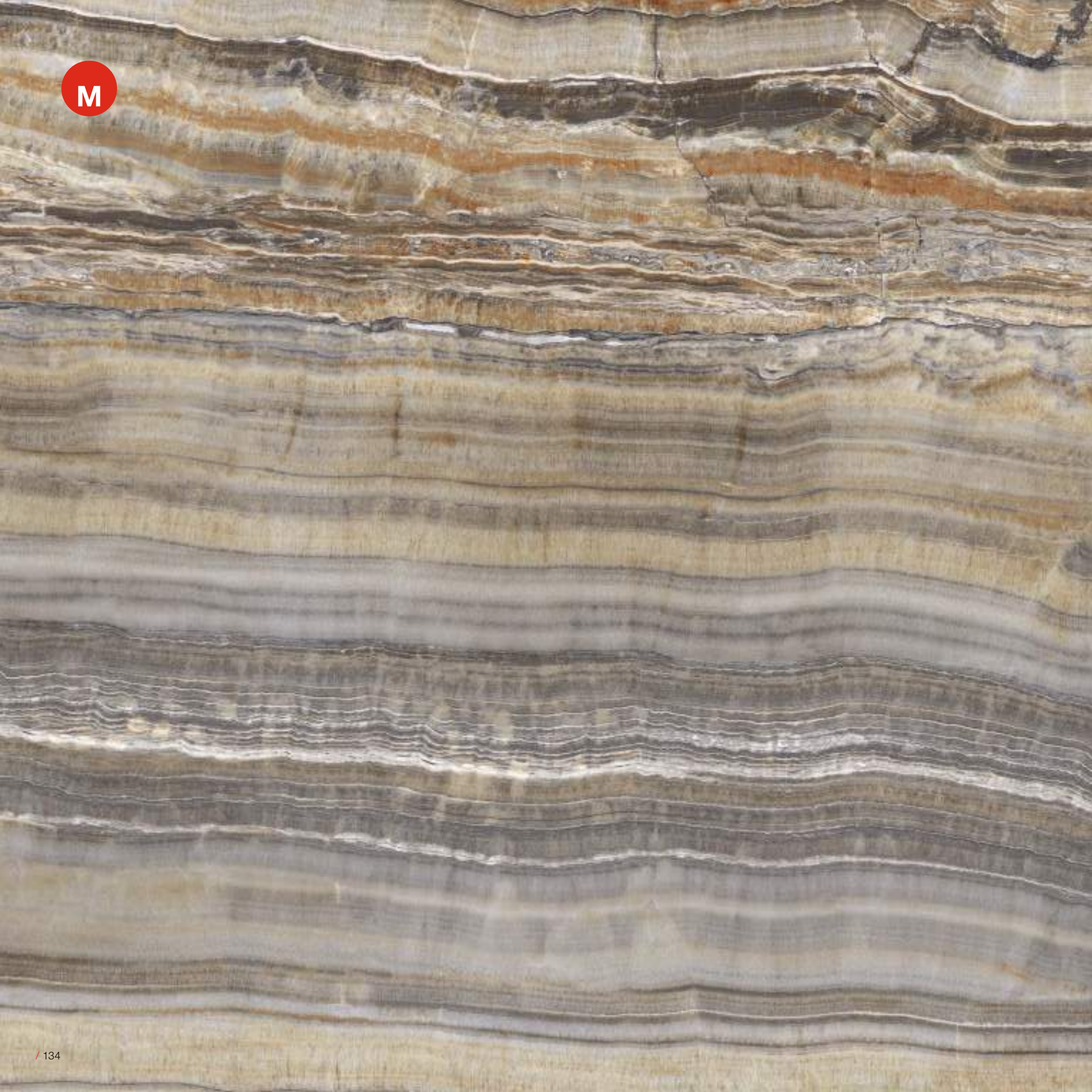

ONICE GRIGIO ONICE

New

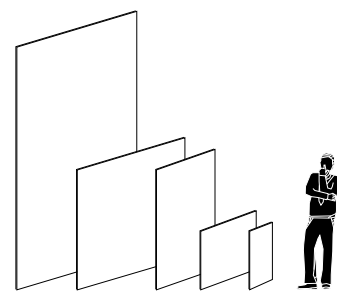

300x150 . 120"x60"

150x150 . 60"x60"

150x75 . 60"x30"

75x75 . 30"x30"

75x37,5 . 30"x15"

X 6 MM

LU LUCIDATO
E SQUADRATO

SY SILKY
E SQUADRATO

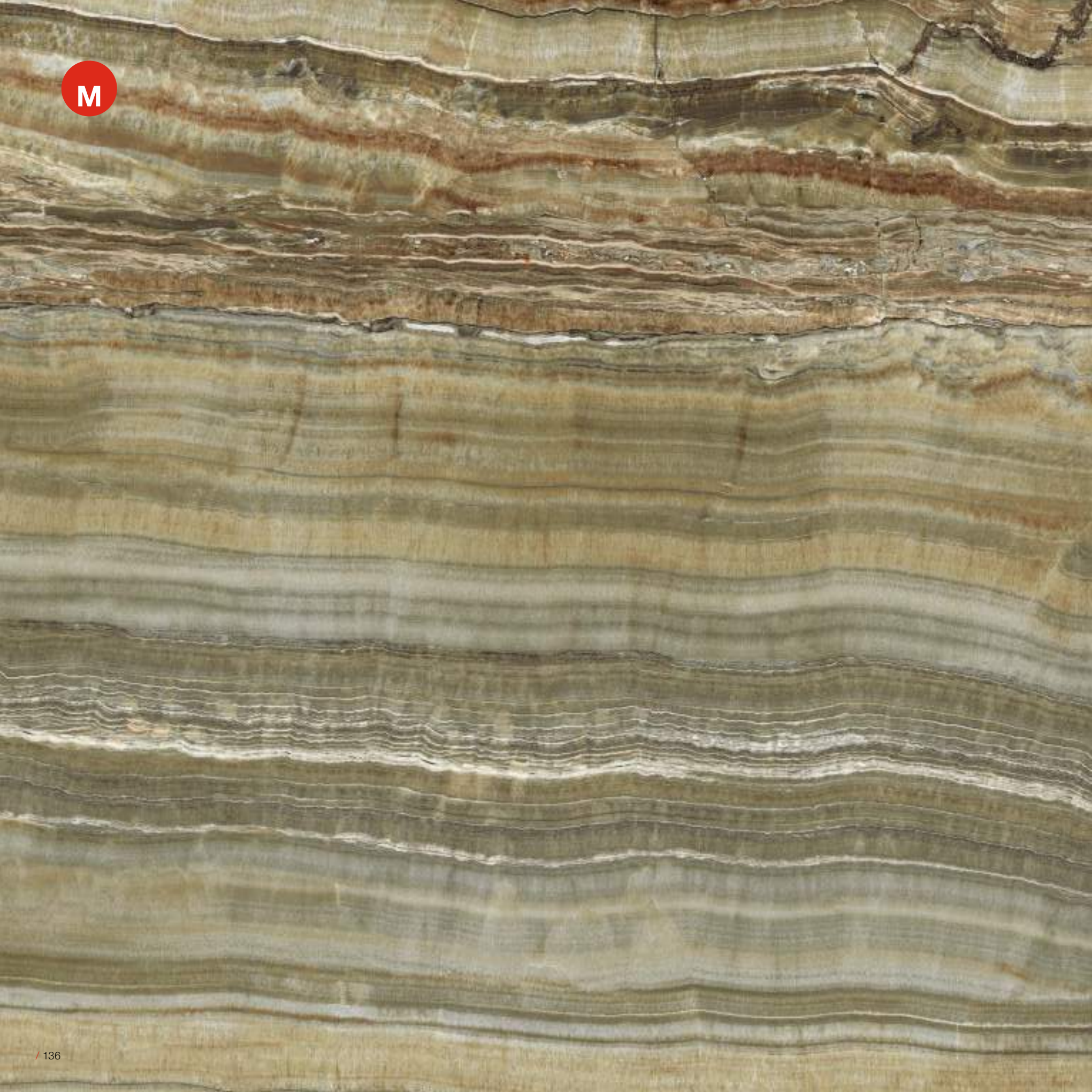

ONICE VERDE ONICE

New

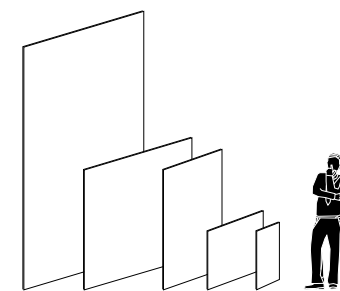

300x150 . 120"x60"

150x150 . 60"x60"

150x75 . 60"x30"

75x75 . 30"x30"

75x37,5 . 30"x15"

X 6 MM

LU LUCIDATO
E SQUADRATO

SY SILKY
E SQUADRATO



ONICE PERLA ONICE

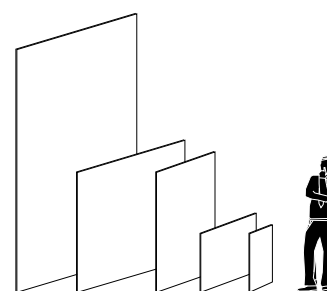

300x150 . 120"x60"

150x150 . 60"x60"

150x75 . 60"x30"

75x75 . 30"x30"

75x37,5 . 30"x15"

 6 MM

 LUCIDATO
E SQUADRATO

 PRELUCIDATO
E SQUADRATO

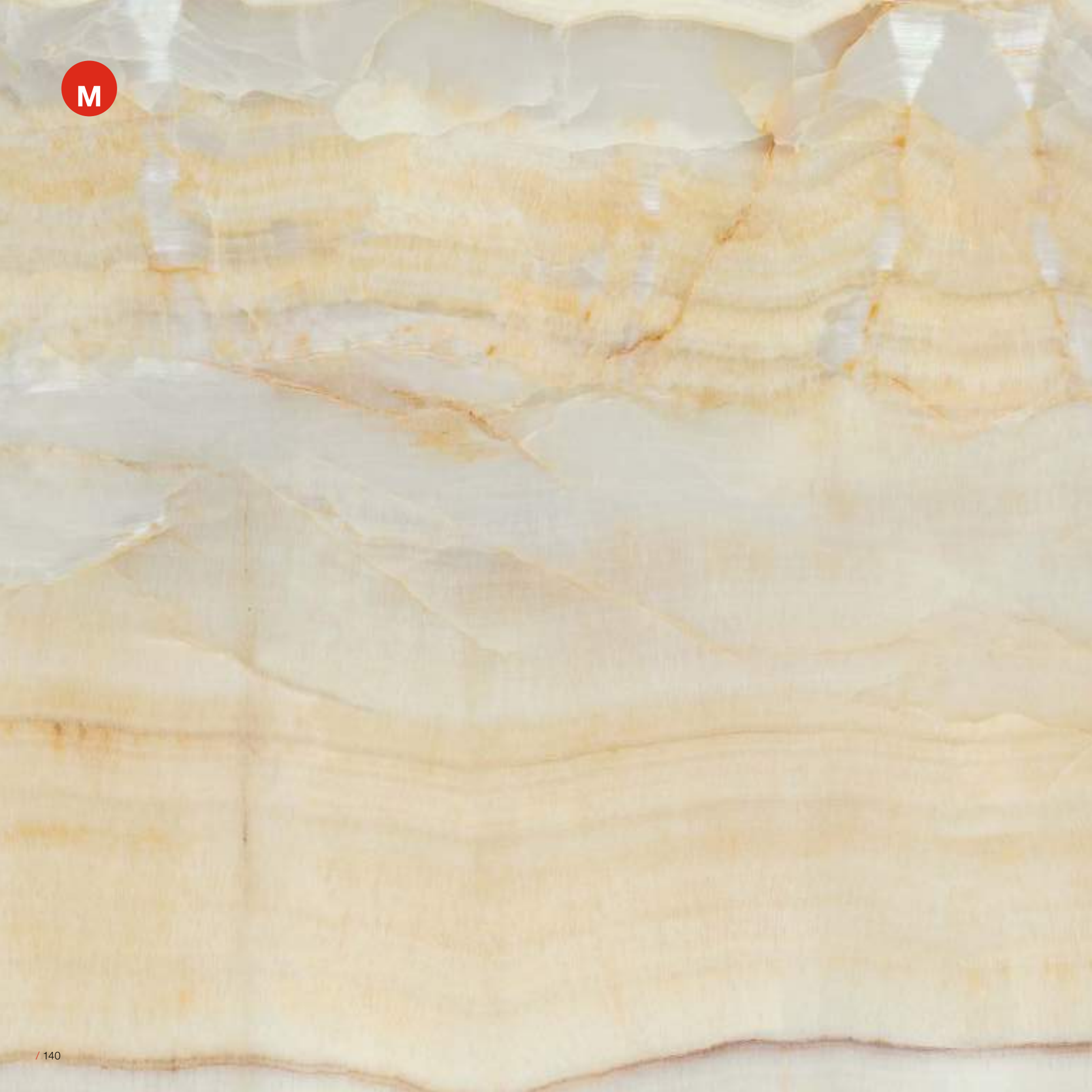

ONICE ORO ONICE

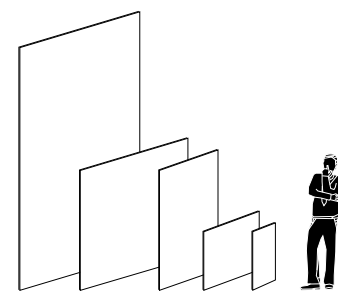

300x150 . 120"x60"

150x150 . 60"x60"

150x75 . 60"x30"

75x75 . 30"x30"

75x37,5 . 30"x15"

X 6 MM

LU LUCIDATO
E SQUADRATO

PL PRELUCIDATO
E SQUADRATO

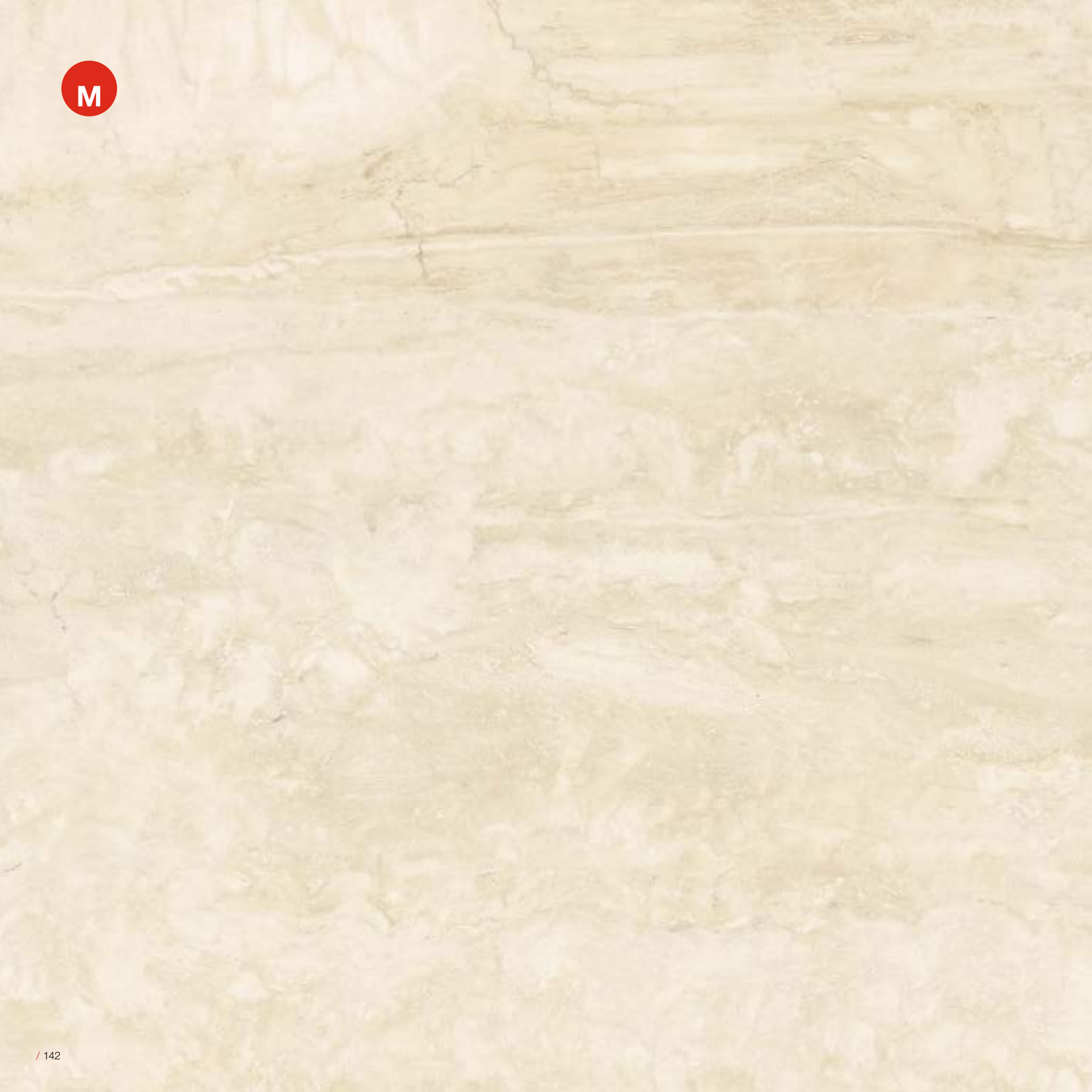

TRAVERTINO CLASSICO

TRAVERTINO

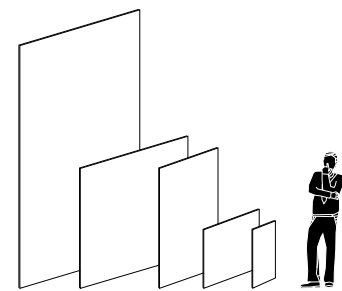
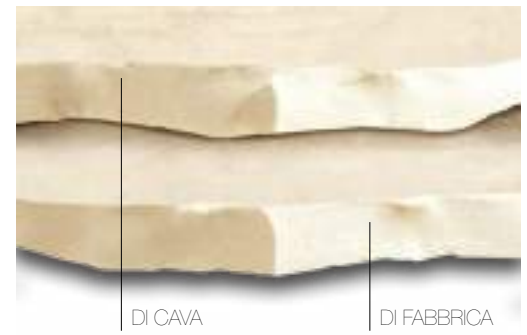

300x150 . 120"x60"

150x150 . 60"x60"

150x75 . 60"x30"

75x75 . 30"x30"

75x37,5 . 30"x15"

 6 MM

 LUCIDATO
E SQUADRATO



TRAVERTINO TRAVERTINO

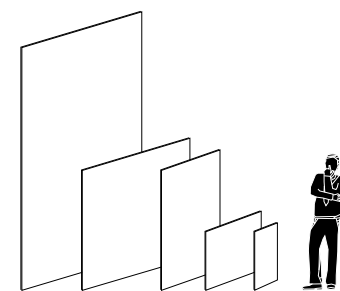

300x150 . 120"x60"

150x150 . 60"x60"

150x75 . 60"x30"

75x75 . 30"x30"

75x37,5 . 30"x15"

X 6 MM

LU LUCIDATO
E SQUADRATO

PL PRELUCIDATO
E SQUADRATO



DOVE CITYSTONE



DI CAVA

DI FABBRICA

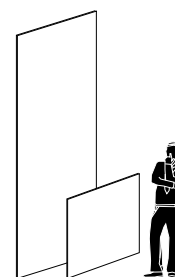

300x100 . 120"x40"

100x100 . 40"x40"

 6 MM

 NATURALE
E QUADRATO



BROWN CITYSTONE

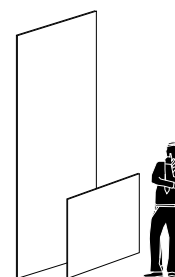
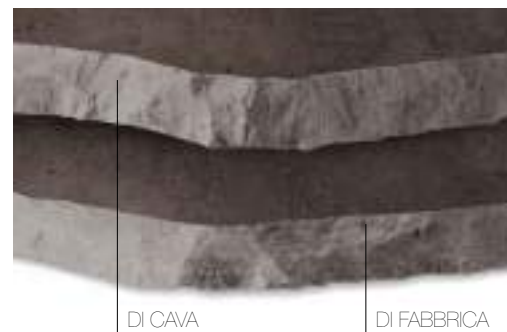

300x100 . 120"x40"

100x100 . 40"x40"

 6 MM

 NATURALE
E SQUADRATO



PEARL CITYSTONE



DI CAVA

DI FABBRICA

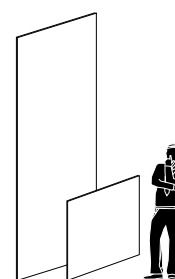

300x100 . 120"x40"

100x100 . 40"x40"

 6 MM

 NATURALE
E QUADRATO



GREY CITYSTONE

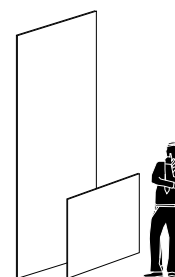
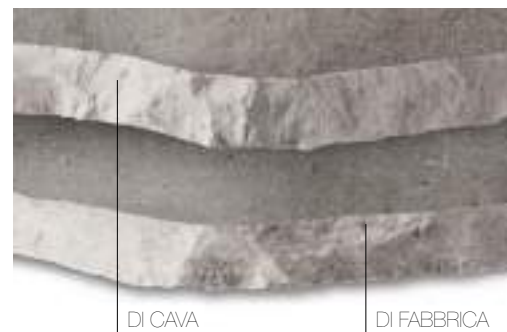

300x100 . 120"x40"

100x100 . 40"x40"

 6 MM

 NATURALE
E SQUADRATO



LIMESTONE MOON

PIETRE

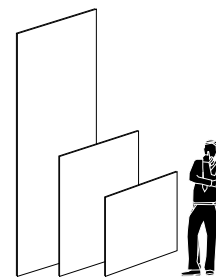

300x100 . 120"x40"

150x100 . 60"x40"

100x100 . 40"x40"

 6 MM

 STRUTTURATO
R10 A+B



LIMESTONE ASH PIETRE



DI CAVA

DI FABBRICA

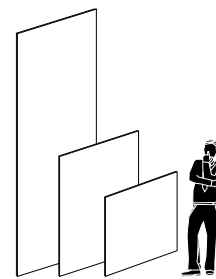

300x100 . 120"x40"

150x100 . 60"x40"

100x100 . 40"x40"

 6 MM

 STRUTTURATO
R10 A+B

LIMESTONE DEEP PIETRE



DI CAVA

DI FABBRICA

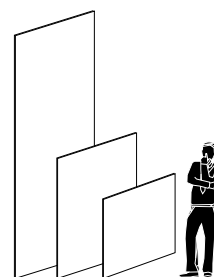

300x100 . 120"x40"

150x100 . 60"x40"

100x100 . 40"x40"

 6 MM

 STRUTTURATO
R10 A+B



LAVICA PEARL PIETRE

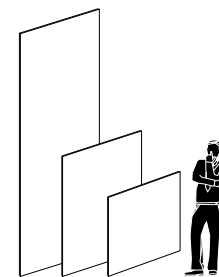

300x100 . 120"x40"

150x100 . 60"x40"

100x100 . 40"x40"

 6 MM

 PRELUCIDATO
E SQUADRATO

 NATURALE
E SQUADRATO



LAVICA BEIGE PIETRE



DI CAVA

DI FABBRICA

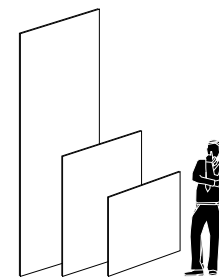

300x100 . 120"x40"

150x100 . 60"x40"

100x100 . 40"x40"

 6 MM

 PL PRELUCIDATO
E SQUADRATO

 N NATURALE
E SQUADRATO



LAVICA DARK PIETRE



DI CAVA

DI FABBRICA

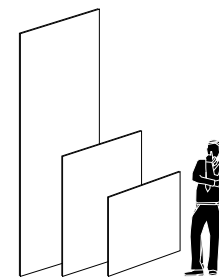

300x100 . 120"x40"

150x100 . 60"x40"

100x100 . 40"x40"

 6 MM

 PRELUCIDATO
E SQUADRATO

 NATURALE
E SQUADRATO



LAVICA GREY PIETRE

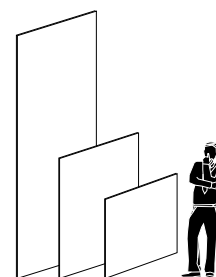

300x100 . 120"x40"

150x100 . 60"x40"

100x100 . 40"x40"

 6 MM

 PRELUCIDATO
E SQUADRATO

 NATURALE
E SQUADRATO



LAVICA BLACK PIETRE



DI CAVA

DI FABBRICA

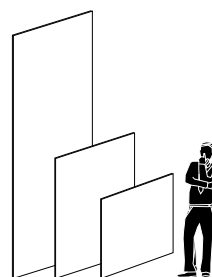

300x100 . 120"x40"

150x100 . 60"x40"

100x100 . 40"x40"

 6 MM

 PRELUCIDATO
E SQUADRATO

 NATURALE
E SQUADRATO

CORTEN

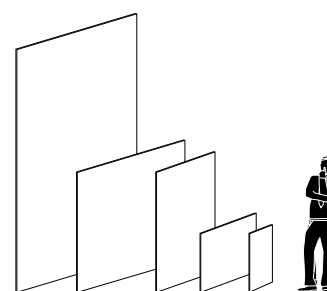

300x150 . 120"x60"

150x150 . 60"x60"

150x75 . 60"x30"

75x75 . 30"x30"

75x37,5 . 30"x15"

 6 MM

 PRELUCIDATO
E SQUADRATO

 NATURALE
E SQUADRATO



BRONZE IRON

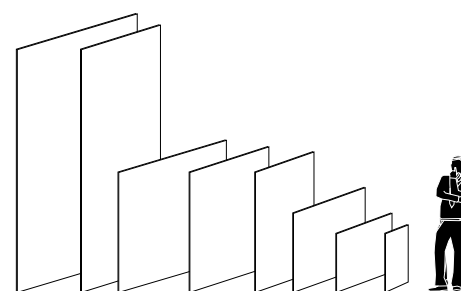

300x150 . 120"x60"

300x100 . 120"x40"

150x150 . 60"x60"

150x100 . 60"x40"

150x75 . 60"x30"

100x100 . 40"x40"

75x75 . 30"x30"

75x37,5 . 30"x15"

 6 MM

 NATURALE
E SQUADRATO



BLACK IRON

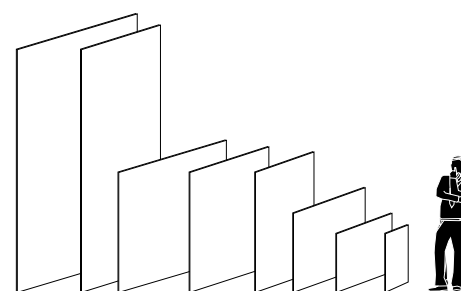

300x150 . 120"x60"

300x100 . 120"x40"

150x150 . 60"x60"

150x100 . 60"x40"

150x75 . 60"x30"

100x100 . 40"x40"

75x75 . 30"x30"

75x37,5 . 30"x15"

 6 MM

 NATURALE
E SQUADRATO



GREY IRON

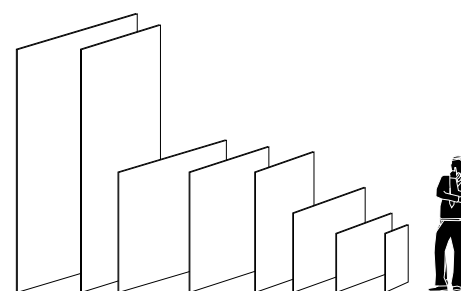

300x150 . 120"x60"

300x100 . 120"x40"

150x150 . 60"x60"

150x100 . 60"x40"

150x75 . 60"x30"

100x100 . 40"x40"

75x75 . 30"x30"

75x37,5 . 30"x15"

 6 MM

 NATURALE
E QUADRATO



WHITE PURITY ROADS

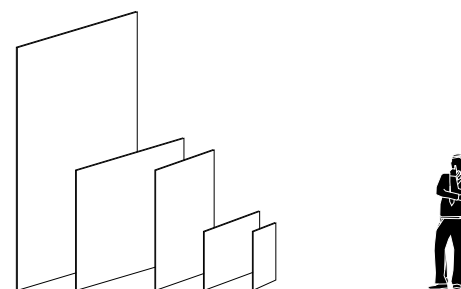

300x150 . 120"x60"

150x150 . 60"x60"

150x75 . 60"x30"

75x75 . 30"x30"

75x37,5 . 30"x15"

 6 MM

 NATURALE
E SQUADRATO



SAND HEART ROADS

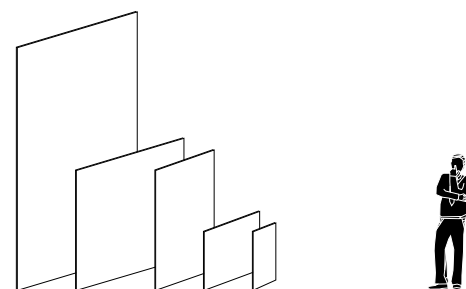

300x150 . 120"x60"

150x150 . 60"x60"

150x75 . 60"x30"

75x75 . 30"x30"

75x37,5 . 30"x15"

 6 MM

 NATURALE
E SQUADRATO

COFFEE TRUTH ROADS

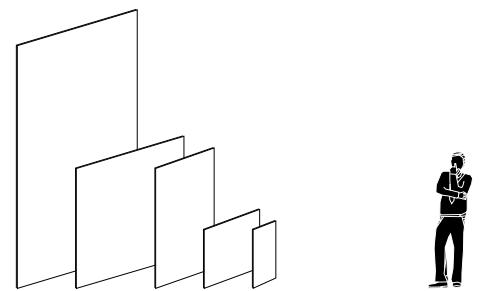

300x150 . 120"x60"

150x150 . 60"x60"

150x75 . 60"x30"

75x75 . 30"x30"

75x37,5 . 30"x15"

 6 MM

 NATURALE
E QUADRATO



PEARL MIND ROADS

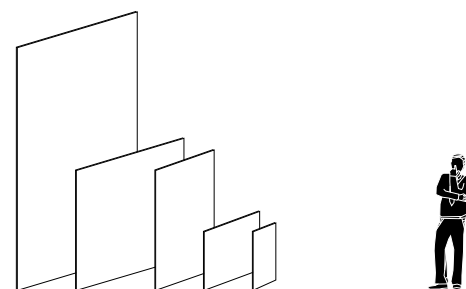

300x150 . 120"x60"

150x150 . 60"x60"

150x75 . 60"x30"

75x75 . 30"x30"

75x37,5 . 30"x15"

 6 MM

 NATURALE
E QUADRATO



GREY CALM ROADS

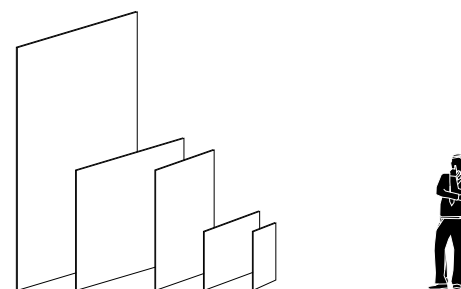

300x150 . 120"x60"

150x150 . 60"x60"

150x75 . 60"x30"

75x75 . 30"x30"

75x37,5 . 30"x15"

 6 MM

 NATURALE
E QUADRATO



DARK DEPTH ROADS

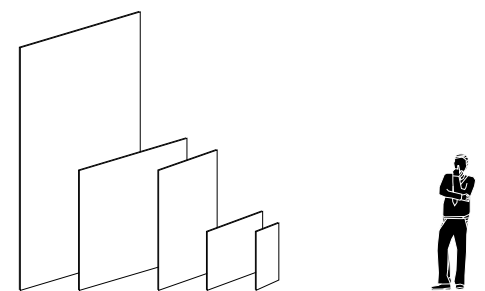

300x150 . 120"x60"

150x150 . 60"x60"

150x75 . 60"x30"

75x75 . 30"x30"

75x37,5 . 30"x15"

 6 MM

 NATURALE
E SQUADRATO



TITANIUM WHITE CHROMOCODE 3D

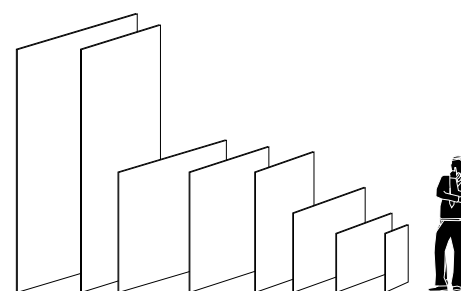

300x150 . 120"x60"

300x100 . 120"x40"

150x150 . 60"x60"

150x100 . 60"x40"

150x75 . 60"x30"

100x100 . 40"x40"

75x75 . 30"x30"

75x37,5 . 30"x15"

 6 MM

 LUCIDATO
E SQUADRATO

 NATURALE
E SQUADRATO



IVORY BLACK CHROMOCODE 3D

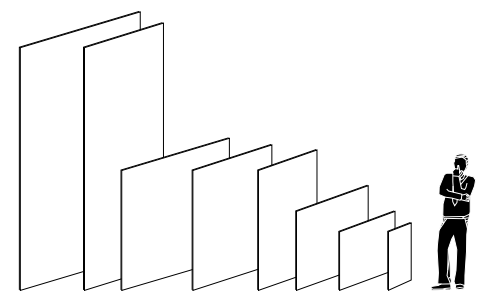

300x150 . 120"x60"

300x100 . 120"x40"

150x150 . 60"x60"

150x100 . 60"x40"

150x75 . 60"x30"

100x100 . 40"x40"

75x75 . 30"x30"

75x37,5 . 30"x15"

 6 MM

 LUCIDATO
E SQUADRATO

 NATURALE
E SQUADRATO

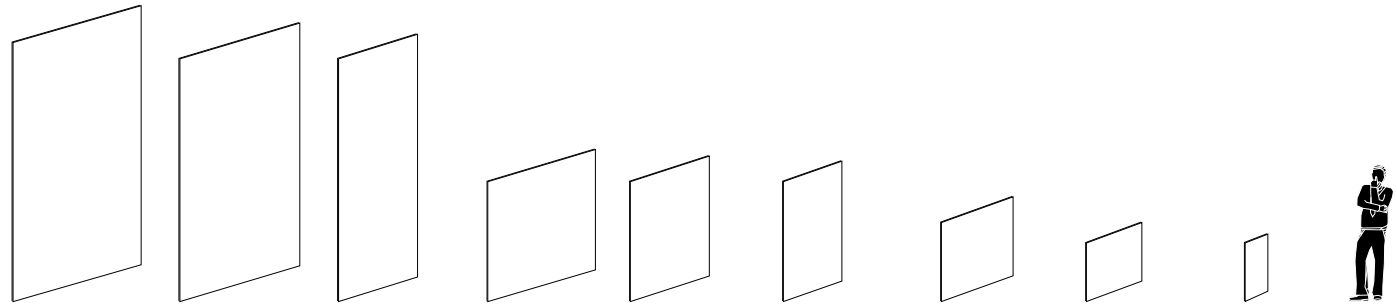

Marble inspiration ✂ 6 MM

320x160* 128"x64"
300x150 120"x60"
300x100 120"x40"
150x150 60"x60"
150x100 60"x40"
150x75 60"x30"
100x100 40"x40"
75x75 30"x30"
75x37,5 30"x15"

MARMI WHITE CALACATTA	LU	*	L315332MF6	-	L150332MF6	-	L175332MF6	-	L75332MF6	L737332MF6
MARMI STATUARIO LIGHT	LU	*	L315334MF6	-	L150334MF6	-	L175334MF6	-	L75334MF6	L737334MF6
MARMI ARABESCATO LIGHT	LU	*	L315333MF6	-	L150333MF6	-	L175333MF6	-	L75333MF6	L737333MF6
MARMI GAUDI STONE	LU	*	L315336MF6	-	L150336MF6	-	L175336MF6	-	L75336MF6	L737336MF6
	PL	*	P315336MF6	-	P150336MF6	-	P175336MF6	-	P75336MF6	P737336MF6
MARMI STONE GREY	LU	*	L315335MF6	-	L150335MF6	-	L175335MF6	-	L75335MF6	L737335MF6
	PL	*	P315335MF6	-	P150335MF6	-	P175335MF6	-	P75335MF6	P737335MF6
MARMI PORTORO	LU	*	L315337MF6	-	L150337MF6	-	L175337MF6	-	L75337MF6	L737337MF6
MARMI ESTREMOZ CREMA	LU	*	L315316MF6	-	L150316MF6	-	L175316MF6	-	L75316MF6	L737316MF6
MARMI CALACATTA	LU	*	L315265MF6	L310265MF6	L150265MF6	L1510265MF6	L175265MF6	L100265MF6	L75265MF6	L737265MF6
	PL	*	P315265MF6	P310265MF6	P150265MF6	P1510265MF6	P175265MF6	P100265MF6	P75265MF6	P737265MF6
MARMI CALACATTA BLOCK-A	LU	*	L315268MF6	-	-	-	-	-	-	-
	PL	*	P315268MF6	-	-	-	-	-	-	-
MARMI CALACATTA BLOCK-B	LU	*	L315267MF6	-	-	-	-	-	-	-
	PL	*	P315267MF6	-	-	-	-	-	-	-
MARMI ALPS HEART	LU	*	L315297MF6	-	L150297MF6	-	L175297MF6	-	L75297MF6	L737297MF6
MARMI CREMA MARFIL EXTRA	LU	*	L315298MF6	-	L150298MF6	-	L175298MF6	-	L75298MF6	L737298MF6
	PL	*	P315298MF6	-	P150298MF6	-	P175298MF6	-	P75298MF6	P737298MF6
MARMI ERAMOSIA	LU	*	L315315MF6	-	L150315MF6	-	L175315MF6	-	-	-
MARMI THASSOS	LU	*	L315189MF6	L310189MF6	L150189MF6	L1510189MF6	L175189MF6	L100189MF6	L75189MF6	L737189MF6
	PL	*	P315189MF6	P310189MF6	P150189MF6	P1510189MF6	P175189MF6	P100189MF6	P75189MF6	P737189MF6
MARMI BIANCO LASA	LU	*	L315326MF6	-	L150326MF6	-	L175326MF6	-	L75326MF6	L737326MF6
	PL	*	P315326MF6	-	P150326MF6	-	P175326MF6	-	P75326MF6	P737326MF6

* Disponibile su richiesta. | Available upon request. | Réalisable sur demande. | Verfügbar auf Anfrage.

✂ 10 MM Disponibile su richiesta. | Available upon request. | Réalisable sur demande. | Verfügbar auf Anfrage.

Marble inspiration ✂ 6 MM

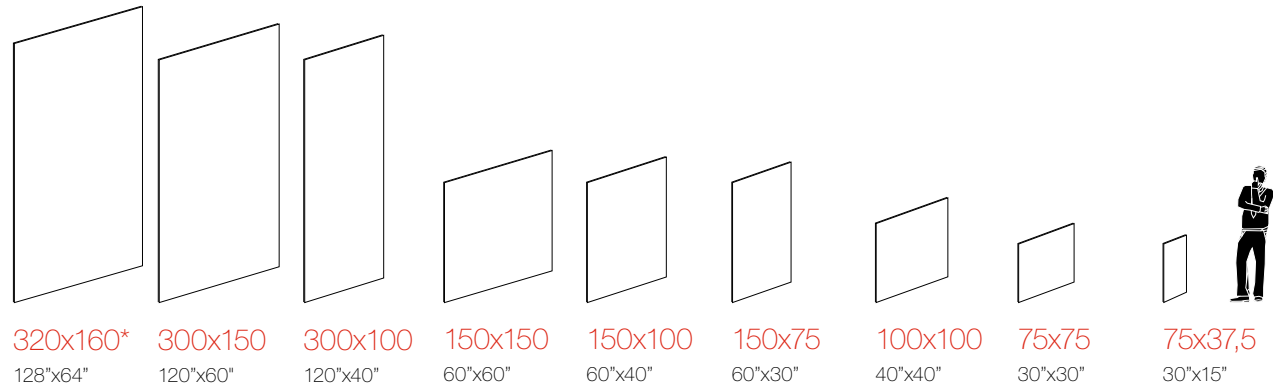

MARMİ BIANCO VENATO EXTRA	LU	*	L315300MF6	-	L150300MF6	-	L175300MF6	-	L75300MF6	L737300MF6
	PL	*	P315300MF6	-	P150300MF6	-	P175300MF6	-	P75300MF6	P737300MF6
MARMİ BIANCO VENATO EXTRA BLOCK-A	LU	*	L315301MF6	-	-	-	-	-	-	-
	PL	*	P315301MF6	-	-	-	-	-	-	-
MARMİ BIANCO VENATO EXTRA BLOCK-B	LU	*	L315302MF6	-	-	-	-	-	-	-
	PL	*	P315302MF6	-	-	-	-	-	-	-
MARMİ ARABESCATO	LU	*	-	-	L150320MF6	-	L175320MF6	-	L75320MF6	L737320MF6
	PL	*	-	-	P150320MF6	-	P175320MF6	-	P75320MF6	P737320MF6
MARMİ ARABESCATO BLOCK-A	LU	*	L315320MF6A	-	-	-	-	-	-	-
	PL	*	P315320MF6A	-	-	-	-	-	-	-
MARMİ ARABESCATO BLOCK-B	LU	*	L315320MF6B	-	-	-	-	-	-	-
	PL	*	P315320MF6B	-	-	-	-	-	-	-
MARMİ EXTRA WHITE	LU	*	L315317MF6	-	L150317MF6	-	L175317MF6	-	L75317MF6	L737317MF6
	PL	*	P315317MF6	-	P150317MF6	-	P175317MF6	-	P75317MF6	P737317MF6
MARMİ EXTRA WHITE BLOCK-A	LU	*	L315318MF6	-	-	-	-	-	-	
MARMİ EXTRA WHITE BLOCK-B	LU	*	L315319MF6	-	-	-	-	-	-	
MARMİ BLUE DE SAVOIE	LU	*	L315327MF6	-	L150327MF6	-	L175327MF6	-	L75327MF6	L737327MF6
	PL	*	P315327MF6	-	P150327MF6	-	P175327MF6	-	P75327MF6	P737327MF6
MARMİ BLACK VENATO	LU	*	L315314MF6	-	L150314MF6	-	L175314MF6	-	L75314MF6	L737314MF6
MARMİ VEINED WHITE	LU	*	L315339MF6	-	L150339MF6	-	L175339MF6	-	L75339MF6	L737339MF6
	SY	*	SY315339MF6	-	SY150339MF6	-	SY175339MF6	-	SY75339MF6	SY737339MF6
MARMİ BLACK MARQUINIA	LU	*	L315338MF6	-	L150338MF6	-	L175338MF6	-	L75338MF6	L737338MF6
	SY	*	SY315338MF6	-	SY150338MF6	-	SY175338MF6	-	SY75338MF6	SY737338MF6
TRAVERTINO CLASSICO	LU	*	L315328MF6	-	L150328MF6	-	L175328MF6	-	L75328MF6	L737328MF6
TRAVERTINO	LU	*	L315288MF6	-	L150288MF6	-	L175288MF6	-	L75288MF6	L737288MF6
	PL	*	P315288MF6	-	P150288MF6	-	P175288MF6	-	P75288MF6	P737288MF6

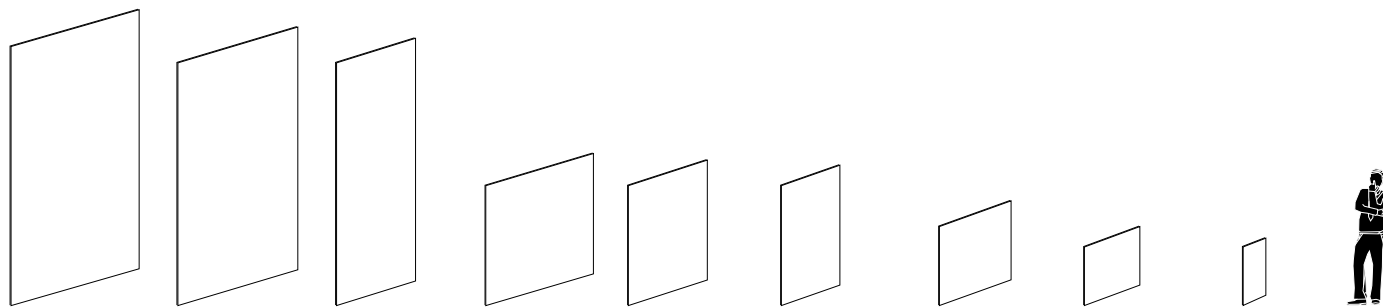

Marble inspiration 6 MM

320x160* 128"x64"
300x150 120"x60"
300x100 120"x40"
150x150 60"x60"
150x100 60"x40"
150x75 60"x30"
100x100 40"x40"
75x75 30"x30"
75x37,5 30"x15"

ONICE PERLA	LU	*	L315290MF6	-	L150290MF6	-	L175290MF6	-	L75290MF6	L737290MF6
	PL	*	P315290MF6	-	P150290MF6	-	P175290MF6	-	P75290MF6	P737290MF6
ONICE ORO	LU	*	L315289MF6	-	L150289MF6	-	L175289MF6	-	L75289MF6	L737289MF6
	PL	*	P315289MF6	-	P150289MF6	-	P175289MF6	-	P75289MF6	P737289MF6
ONICE AVORIO	LU	*	L315340MF6	-	L150340MF6	-	L175340MF6	-	L75340MF6	L737340MF6
	SY	*	SY315340MF6	-	SY150340MF6	-	SY175340MF6	-	SY75340MF6	SY737340MF6
ONICE GRIGIO	LU	*	L315341MF6	-	L150341MF6	-	L175341MF6	-	L75341MF6	L737341MF6
	SY	*	SY315341MF6	-	SY150341MF6	-	SY175341MF6	-	SY75341MF6	SY737341MF6
ONICE VERDE	LU	*	L315342MF6	-	L150342MF6	-	L175342MF6	-	L75342MF6	L737342MF6
	SY	*	SY315342MF6	-	SY150342MF6	-	SY175342MF6	-	SY75342MF6	SY737342MF6

* Disponibile su richiesta. | Available upon request. | Réalisable sur demande. | Verfügbar auf Anfrage.

10 MM Disponibile su richiesta. | Available upon request. | Réalisable sur demande. | Verfügbar auf Anfrage.

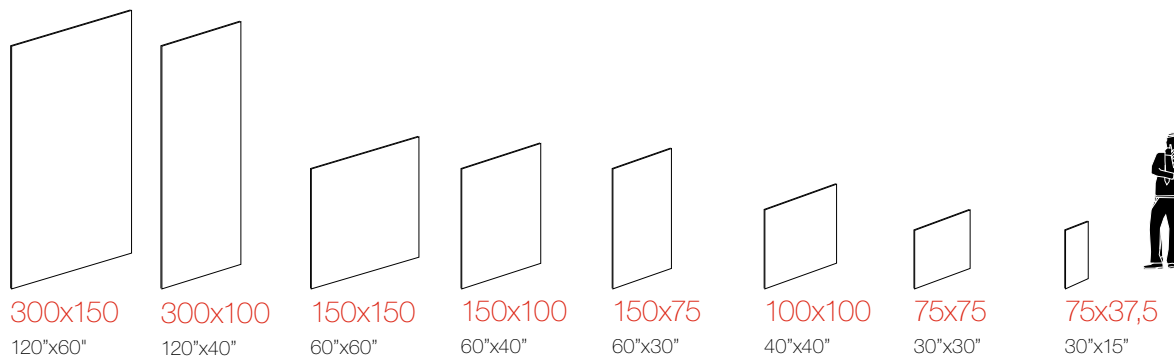

Iron inspiration 6 MM







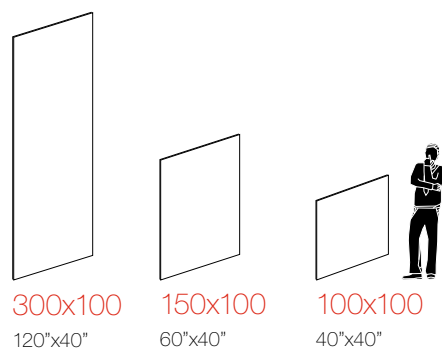

300x150 120"x60"
300x100 120"x40"
150x150 60"x60"
150x100 60"x40"
150x75 60"x30"
100x100 40"x40"
75x75 30"x30"
75x37,5 30"x15"

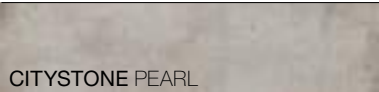
CORTEN	PL	L315276MF6	-	L150276MF6	-	L175276MF6	-	L75276MF6	L737276MF6
	N	P315276MF6	-	P150276MF6	-	P175276MF6	-	P75276MF6	P737276MF6
IRON BRONZE	N	P315330MF6	P310330MF6	P150330MF6	P1510330MF6	P175330MF6	P100330MF6	P75330MF6	P737330MF6
IRON BLACK	N	P315329MF6	P310329MF6	P150329MF6	P1510329MF6	P175329MF6	P100329MF6	P75329MF6	P737329MF6
IRON GREY	N	P315331MF6	P310331MF6	P150331MF6	P1510331MF6	P175331MF6	P100331MF6	P75331MF6	P737331MF6

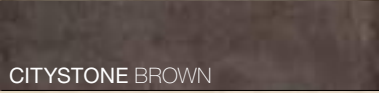
10 MM Disponibile su richiesta. | Available upon request. | Réalisable sur demande. | Verfügbar auf Anfrage.

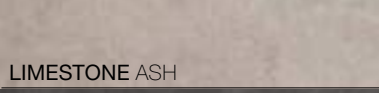
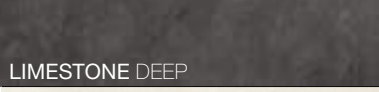
Stone inspiration  6 MM

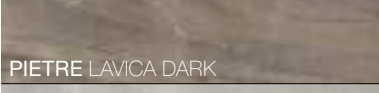

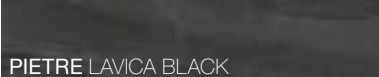
	N	P310333MF6	-	P100333MF6
	N	P310334MF6	-	P100334MF6
	N	P310335MF6	-	P100335MF6
	N	P310336MF6	-	P100336MF6
	ST R10 A+B	P310311MF6	P1510311MF6	P100311MF6
	ST R10 A+B	P310312MF6	P1510312MF6	P100312MF6
	ST R10 A+B	P310313MF6	P1510313MF6	P100313MF6
	PL	L310303MF6	-	L100303MF6
	N	P310303MF6	P1510303MF6	P100303MF6
	PL	L310306MF6	-	L100306MF6
	N	P310306MF6	P1510306MF6	P100306MF6
	PL	L310305MF6	-	L100305MF6
	N	P310305MF6	P1510305MF6	P100305MF6
	PL	L310304MF6	-	L100304MF6
	N	P310304MF6	P1510304MF6	P100304MF6
	PL	L310307MF6	-	L100307MF6
	N	P310307MF6	P1510307MF6	P100307MF6

LU	LUCIDATO E SQUADRATO
SY	SILKY E SQUADRATO
PL	PRELUCIDATO E SQUADRATO
N	NATURALE E SQUADRATO
ST	STRUTTURATO R10 A+B

 10 MM Disponibile su richiesta. | Available upon request. | Réalisable sur demande. | Verfügbar auf Anfrage.

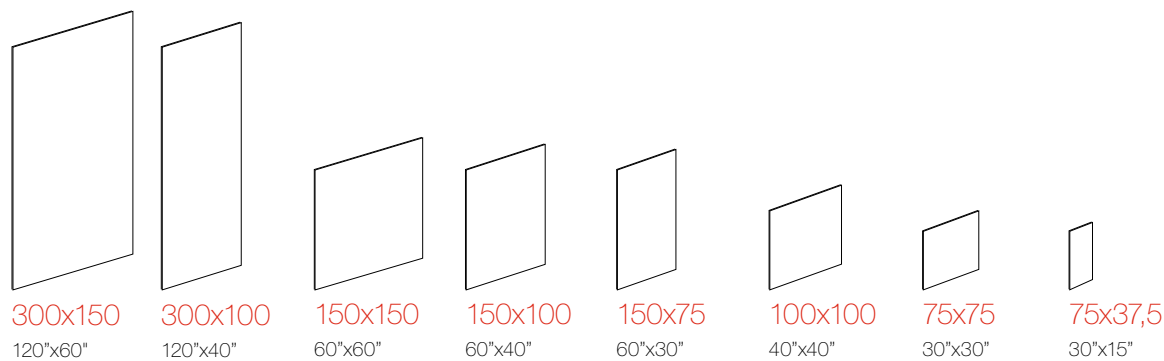

Design inspiration 6 MM

ROADS WHITE PURITY	N	P315197MF6	-	P150197MF6	-	P175197MF6	-	P75197MF6	P737197MF6
ROADS SAND HEARTH	N	P315198MF6	-	P150198MF6	-	P175198MF6	-	P75198MF6	P737198MF6
ROADS COFFEE TRUTH	N	P315199MF6	-	P150199MF6	-	P175199MF6	-	P75199MF6	P737199MF6
ROADS PEARL MIND	N	P315200MF6	-	P150200MF6	-	P175200MF6	-	P75200MF6	P737200MF6
ROADS GREY CALM	N	P315201MF6	-	P150201MF6	-	P175201MF6	-	P75201MF6	P737201MF6
ROADS DARK DEPTH	N	P315202MF6	-	P150202MF6	-	P175202MF6	-	P75202MF6	P737202MF6
CHROMOCODE 3D TITANIUM WHITE	LU	L315240MF6	L310240MF6	L150240MF6	L1510240MF6	L175240MF6	L100240MF6	L757240MF6	L737240MF6
	N	P315240MF6	P310240MF6	P150240MF6	P1510240MF6	P175240MF6	P100240MF6	P757240MF6	P737240MF6
CHROMOCODE 3D IVORY BLACK	LU	L315247MF6	L310247MF6	L150247MF6	L1510247MF6	L175247MF6	L100247MF6	L757247MF6	L737247MF6
	N	P315247MF6	P310247MF6	P150247MF6	P1510247MF6	P175247MF6	P100247MF6	P757247MF6	P737247MF6

10 MM Disponibile su richiesta. | Available upon request. | Réalisable sur demande. | Verfügbar auf Anfrage.

Disponibile su richiesta. | Available upon request. | Réalisable sur demande. | Verfügbar auf Anfrage.

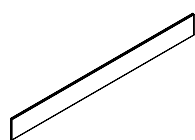

Zoccolino
150x10 cm - 60"x4"
100x10 cm - 40"x4"
75x10 cm - 30"x4"

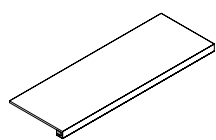

Scalino Costa retta
150x35x4 cm - 60"x14"x2"
100x35x4 cm - 40"x14"x2"

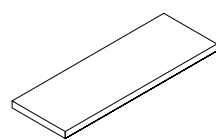

Angolo Scalino Costa retta
150x35x4 cm - 60"x14"x2"
100x35x4 cm - 40"x14"x2"

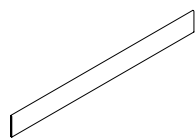

**Battiscopa
BECCO DI CIVETTA**
75x9 cm - 30"x4"

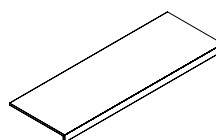

Scalino Bordo dritto
150x35x4 cm - 60"x14"x2"
100x35x4 cm - 40"x14"x2"

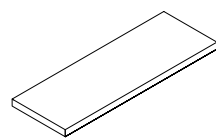

Angolo Scalino Bordo dritto
150x35x4 cm - 60"x14"x2"
100x35x4 cm - 40"x14"x2"

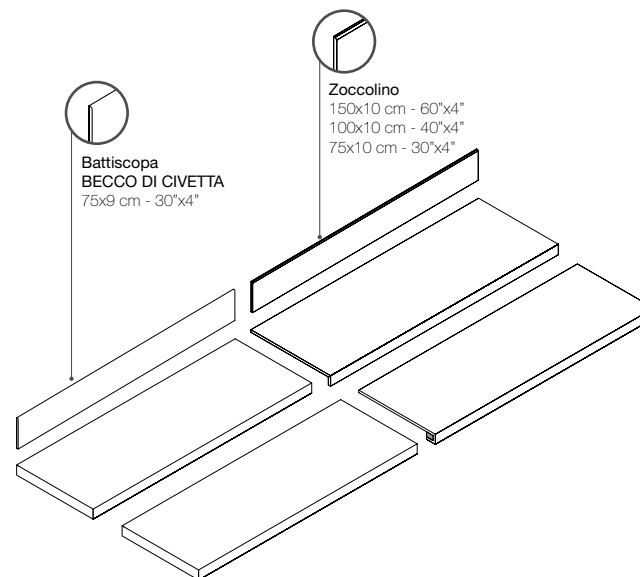

Delivered with **random veins**

VENATURA DELLE LASTRE E APPRONTAMENTO ORDINI

Per garantire la migliore resa estetica, le lastre Maxfine presentano un certo numero di facce differenti.

Nell'approntamento degli ordinativi, la selezione delle lastre rispetta la casualità tipica dei materiali naturali: non è perciò possibile garantire la continuità nel disegno della venatura tra i vari pezzi spediti. Maxfine nasce dalla combinazione della terra con il fuoco: l'eventuale continuità della venatura tra lastre diverse soggiace alla tipica tolleranza dei prodotti naturali.

SLAB VEINS AND ORDER PREPARATION

To ensure optimal aesthetic performance, Maxfine slabs have a certain number of different faces.

During order preparation, slabs are randomly selected to reproduce the random nature of natural materials: this means we cannot guarantee continuity of the veins between the various different pieces shipped. Maxfine is produced by the combination of earth and fire: continuity of veins between slabs is subject to the tolerance typical of natural materials.

VEINES DES DALLES ET PREPARATION COMMANDES

Pour garantir le meilleur rendement esthétique, les dalles Maxfine présentent un certain nombre de faces différentes.

Lors de la préparation des commandes, la sélection des dalles respecte le caractère aléatoire typique des matériaux naturels: par conséquent, il n'est pas possible de garantir la continuité du dessin des veines entre les différentes pièces expédiées. Maxfine naît de la combinaison de la terre avec le feu: l'éventuelle continuité des veines entre différentes dalles correspond à la tolérance typique des produits naturels.

PLATTENMASERUG UND AUFTRAGSVORBEREITUNG

Für die beste Ästhetik bei der Anwendung weisen die Platten Maxfine eine gewisse Anzahl unterschiedlicher Oberseiten auf.

Bei der Vorbereitung der Aufträge entspricht die Auswahl der Platten dem typischen Zufallsprinzip der natürlichen Materie: es kann von daher keine Kontinuität bei der Maserung unter den verschiedenen versandten Stücken garantiert werden. Maxfine entsteht aus der Kombination von Erde und Feuer: eine ggf. vorhandene Kontinuität der Maserung auf den Platten unterliegt der typischen Toleranz der Naturprodukte.

Nominal **sizes**

TUTTI I FORMATI SONO NOMINALI.

FMG Fabbrica Marmi e Graniti si riserva la facoltà di modificare in qualunque momento le informazioni e le caratteristiche illustrate in questo catalogo, che non sono comunque da ritenere legalmente vincolanti. I colori e le caratteristiche estetiche dei prodotti sono quanto più possibile vicini a quelli reali, nei limiti consentiti dai processi di stampa.

ALL SIZES ARE NOMINAL.

FMG Fabbrica Marmi e Graniti reserves the right to modify the information and the characteristics illustrated in this catalogue (which are in any case not legally binding) at any moment.

The colours and appearance features of the products are as close as possible to reality, within the limitation of the printing process.

TOUS LES FORMATS SONT NOMINAUX.

FMG Fabbrica Marmi e Graniti se réserve la faculté de modifier à tout moments les informations et les caractéristiques figurant dans le présent catalogue, lesquelles n'engagent pas par le fabricant au plan légal. Les couleurs et les caractéristiques esthétiques sont fidèles aux couleurs et caractéristiques réelles dans les limites des procédés d'impression.

ALLE FORMATE SIND NENNWERTE.

Die Firma FMG Fabbrica Marmi e Graniti behält sich vor, die in diesem Katalog enthaltenen Informationen und Eigenschaften jederzeit zu ändern; sie gelten auf keinen Fall als gesetzlich bindend. Die Farben und ästhetischen Eigenschaften der Produkte kommen innerhalb der Möglichkeiten der Druckverfahren den tatsächlichen Eigenschaften so weit wie möglich nahe.

Chromatic variations

La trasformazione di materie prime naturali, associata all'utilizzo di innovative tecnologie di produzione brevettate, consente di ottenere materiali dalle elevate prestazioni tecniche, che si distinguono per i tipici effetti a tutto spessore da sempre prerogativa esclusiva dei marmi e delle pietre di cava.

Le variazioni cromatiche, di venatura e le piccole puntature sono pertanto caratteristiche di alto pregio dei materiali FMG, ricercate e volute proprio al fine di ricreare la suggestione di una pavimentazione esclusiva, in cui si possa riscoprire la casualità e la bellezza dei materiali naturali. In ragione di quanto sopra i riferimenti cromatici presentati su cataloghi e campionature sono da intendersi puramente indicativi.

The processing of natural raw materials, combined with the use of leading-edge patented production techniques, makes it possible to obtain high-tech materials characterized by typical full-body effects, a feature that has always been the exclusive hallmark of quarried marble and stone.

Chromatic variations, veining and speckling are thus prized characteristics of FMG materials, designed and produced to recreate the fascination of exclusive floorings, that reveal the randomness and beauty of natural materials. On the basis of the above statements, the colour references in the catalogues and samples are to be considered as approximate.

La transformation de matières premières naturelles, allée à l'application de technologies de production d'avant-garde brevetées, permet d'obtenir des matériaux capables de performances techniques élevées se distinguant par leurs effets pleine masse typiques qui sont depuis toujours la prérogative exclusive des marbres et des pierres de carrière.

Les variations chromatiques, les veines et les petits points sont donc des caractéristiques de grande valeur des matériaux FMG, recherchées et voulues dans le but de recréer la suggestion d'un sol exclusif grâce auquel il est possible de redécouvrir l'impondérable et la splendeur des matériaux naturels. C'est la raison pour laquelle les références chromatiques présentées sur les catalogues et les échantillons ne sont données qu'à titre indicatif.

Die Umwandlung von natürlichen Rohmaterialien mit Hilfe von innovativen und patentierten Produktionstechnologien, ermöglicht die Herstellung von Materialien mit hoher technischer Leistungsfähigkeit, die sich durch die typischen vollgemischten Effekte unterscheiden und die seit jeher die charakteristische Besonderheit der Marmorarten und der Steine aus dem Steinbruch sind.

Die farblichen Unterschiede, die Äderungen und die kleinen Punkte sind aus diesem Grund charakteristische Eigenschaften der Materialien FMG von besonderem Wert. Diese "Unvollkommenheiten" sind besonders gewählt und gewollt, um einen exklusiven Bodenbelag zu erzielen, bei dem die Zufälligkeit und die Schönheit der natürlichen Materialien voll zum Ausdruck kommen können. Angesichts der oben aufgeführten Tatsache sind die Farben der Kataloge und der Muster unverbindlich.



PAVIMENTO POSA TRADIZIONALE

La posa delle lastre **MAXFINE** richiede condizioni di posa simili a quelle richieste per lastre in formato tradizionale. **MAXFINE** richiede l'utilizzo della tecnica a doppia spalmatura, ovvero il collante deve essere applicato sia sul fondo di posa che sul retro della lastra.

Per la posa a pavimento, **MAXFINE** richiede le migliori condizioni di sottofondo:

- planarità;
- pulizia da polvere, detriti ed eliminazione di grumi di cemento;
- il fondo di posa deve essere omogeneo e avere già compiuto il ritiro igrometrico di maturazione;
- riparazione di eventuali fessurazioni;
- i dislivelli di planarità devono essere colmati con idonei prodotti di rasatura.

Strumentazione necessaria

- Collante in polvere a base cementizia a letto pieno di classe "C2E secondo le normative EN 12004 e S1 secondo la normativa EN 12002"
- spatola a denti quadri 3x3 mm e spatola a denti tondi 15 mm;
- telaio a ventosa per la movimentazione o biventosa
- battitore in plastica antirimbato 170x370 mm;
- sistema livellante: base + cuneo + pinza.

Fasi di lavorazione

INCOLLAGGIO A PAVIMENTO

- 1) Assicurarsi che la superficie da rivestire sia consistente, planare, priva di polvere e unti/grassi.
- 2) Utilizzare i collanti sopra descritti miscelati in base alle specifiche indicate nella scheda tecnica del collante prescelto.
- 3) Stendere il collante sulla superficie da rivestire con spatola a denti tondi 15 mm per un'area superiore di 5/10 cm rispetto alle dimensioni della lastra.
- 4) Con la lastra in posizione verticale sul telaio di movimentazione, stendere il collante sul retro della lastra con spatola a denti quadri 3x3 mm.
- 5) Con l'utilizzo del telaio a ventosa portare la lastra in posizione orizzontale e posarla.
- 6) Per garantire l'incollaggio uniforme della lastra, si deve utilizzare apposito battitore in plastica anti-rimbato 170x370 mm, effettuando una battitura dal centro verso i bordi per eliminare eventuali sacche d'aria fra il retro della lastra, il collante ed il fondo di posa.
- 7) Utilizzo di sistema livellante.

SISTEMA LIVELLANTE

Il sistema livellante è volto a garantire con semplicità e rapidità pavimenti perfettamente livellati eliminando i dislivelli ("denti") tra le lastre. Il sistema livellante è vivamente consigliato per la posa delle lastre **MAXFINE**.

Strumentazione necessaria

- Base;
- Cuneo;
- Pinza regolabile per installazione a pavimento / rivestimento.

Applicazione del sistema livellante

Posizionamento della base:

- a) Dopo avere steso il collante inserire la base al di sotto della lastra **MAXFINE** in corrispondenza dei 4 lati.
- b) In funzione del formato della lastra posizionare uno o più supporti per ogni lato della lastra.
- c) Posizionare la lastra.

Inserimento del cuneo:

- a) Inserire il cuneo nella feritoia del supporto facendo attenzione a non superare il punto di rottura.
- b) Per agevolare l'inserimento del cuneo si consiglia l'uso della pinza a trazione regolabile.

Eliminazione del supporto:

- a) A maturazione del collante avvenuta, la parte sporgente del supporto si separa dalla base battendo con il piede nella direzione della linea di fuga.

CONSIGLI GENERALI DI STUCCATURA

Fare attenzione nella scelta dei sigillanti per le fughe; controllare le schede tecniche, sceglierli possibilmente tono su tono e seguire scrupolosamente i tempi di pulizia consigliati in quanto diversi sigillanti colorati di nuova generazione, contengono pigmenti ed additivi che possono essere particolarmente tenaci.

Per le superfici levigate/lucidate non adoperare stucchi epossidici o malte flessibili a base di materiali sintetici (Flexfughe) e non aggiungere additivi/lattici allo stucco in quanto essi rendono estremamente difficoltosa l'eliminazione dei residui coi normali prodotti di pulizia. Qualora si decida comunque di utilizzarli, si raccomanda di eseguire sempre una prova preventiva fuori d'opera.

TRADITIONAL FLOOR LAYING

Laying **MAXFINE** slabs requires similar laying conditions to those required for traditional format slabs. **MAXFINE** requires the adhesive to be applied both on the setting bed and on the back of the slab.

MAXFINE slabs for flooring require the following conditions:

- A flat surface;
- Clean and free from dust, scraps and any lumps of cement;
- The setting bed must be uniform and have already undergone the drying shrinkage process;
- Repair of any cracks;
- Any uneven parts on the surface must be filled with suitable levelling compounds.

Instruments required

- Cement-based powder adhesive for full spread, class "C2E according to EN12004 and S1 according to EN12002 standards";
- 3x3 mm square toothed trowel and 15 mm round toothed trowel;
- Frame with suction cups for handling or double suction cups;
- Non-bounce plastic mallet 170x370 mm;
- Levelling system: base clip + wedge + pliers.

Processing stages

BONDING TO THE FLOOR

- 1) Ensure that the surface to be covered is solid, flat and free from dust and oil/grease.
- 2) Use the adhesives described above mixed according to the specifications indicated in the technical data sheet of the chosen adhesive.
- 3) Spread the adhesive onto the surface to be covered with a 15 mm round toothed trowel across an area of 5/10 cm more than the dimensions of the slab.
- 4) With the slab in a vertical position on the handling frame, spread the adhesive onto the back of the slab with a 3x3 mm square toothed trowel.
- 5) Using the frame with suction cups, bring the slab into a horizontal position and lay it.
- 6) To guarantee uniform bonding of the slab, the special 170x370 mm non-bounce plastic mallet must be used, tapping from the middle towards the edges so as to remove any air pockets between the back of the slab, the adhesive and the surface to be tiled.
- 7) Using the levelling system.

LEVELLING SYSTEM

The levelling system aims to guarantee perfectly levelled floors simply and quickly, eliminating any unevenness between the slabs. The levelling system is strongly recommended for laying **MAXFINE** slabs.

Instruments required

- Base clip;
- Wedge;
- Adjustable pliers for installing floors/wall tiles.

Application of the levelling system

Positioning the base clip:

- a) After spreading the adhesive, insert the base clip below the **MAXFINE** slab on the 4 sides.
- b) Depending on the format of the slab, position one or more supports for each side of the slab.
- c) Position the slab.

Inserting the wedge:

- a) Insert the wedge in the slot of the support, taking care not to exceed the breaking point.
- b) To make inserting the wedge easier, it is recommended to use the adjustable pliers.

Removing the support:

- a) Once the adhesive has dried, the protruding part of the support can be separated from the base clip by tapping with your foot in line with the joint.

GENERAL ADVICE FOR GROUTING

Pay attention while choosing joint sealants: check the technical sheets, choose them shade-matched and follow carefully the recommended cleaning times, as many new generation coloured sealants contain pigments and additives that can be very strong. For polished/glossy surfaces do not use epoxy grouts or synthetic based flexible mortars (Flexfughe) and do not add additives/latexes to the grout, as they make the removal of residues with standard detergents very difficult. However, should you decide to use them, it is recommended to make a previous test off site.



SOL, POSE TRADITIONNELLE

La pose des dalles **MAXFINE** exige des conditions de pose analogue à celles demandées pour les dalles de format traditionnel. **MAXFINE** exige la technique du double encollage: la colle doit être appliquée sur la sous-couche et au dos de la dalle.

Pour la pose au sol, **MAXFINE** exige les meilleures conditions de sous-couche :

- planéité
- dépoussiérage, suppression de débris et de grumeaux de béton
- la sous-couche doit être homogène et avoir déjà effectué le retrait hygrométrique de maturation
- réparation d'éventuelles fissurations
- les dénivelés de planéité doivent être comblés avec des produits de ragréage appropriés

Outils nécessaires

- ciment-colle en poudre à lit plein classe C2E selon les EN 12004 et S1 selon l'EN 12002
- spatule à dents carrées 3x3 mm et spatule à dents rondes 15 mm
- châssis à ventouse pour la manutention ou biventouse
- batteur en plastique anti-rebond 170x370 mm
- système de ragréage : base + coin + pince

Phases d'exécution

ENCOLLAGE AU SOL

- 1) Assurez-vous que la surface à revêtir est consistante, plane, dépoussiérée, sans graisse/huile.
- 2) Utilisez les colles décrites plus haut mélangées selon les spécifications indiquées sur la fiche technique du produit choisi.
- 3) Étalez la colle sur la surface à revêtir à l'aide d'une spatule à dents rondes 15 mm, en débordant de la dalle de 5/10 cm.
- 4) En tenant la dalle à la verticale sur le châssis de manutention, étalez la colle à l'aide de la spatule à dents carrées 3x3 mm au dos de la dalle.
- 5) À l'aide du châssis à ventouse, mettez la dalle à l'horizontale et posez-la.
- 6) Pour garantir l'encollage uniforme de la dalle, vous devrez utiliser un batteur spécial en plastique anti-rebond 170x370 mm et battre du centre vers les bords pour chasser les bulles d'air coincées entre le dos de la dalle, la colle et la sous-couche.
- 7) Utilisation du système de ragréage.

SYSTÈME DE RAGRÉAGE

Le système de ragréage est destiné à garantir, simplement et rapidement, des sols parfaitement mis de niveau en supprimant les dénivelés entre les dalles. Le système de ragréage est vivement conseillé pour la pose des dalles **MAXFINE**.

Outils nécessaires

- Base
- Coin
- Pince réglable pour pose au sol/ au mur

Application du système de ragréage

Positionnement de la base:

- a) Après avoir étalé la colle, insérez la base sous la dalle **MAXFINE** des 4 côtés.
- b) En fonction du format de la dalle, positionnez un ou plusieurs supports de chaque côté de celle-ci.
- c) Positionnez la dalle.

Insertion du coin:

- a) Insérez le coin dans la fente du support en faisant attention à ne pas dépasser le point de rupture.
- b) Pour faciliter l'insertion du coin, il est conseillé d'utiliser la pince de traction réglable.

Élimination du support:

- a) Dès que la colle est arrivée à maturation, séparez de la base la partie qui dépasse du support en battant du pied dans la direction de la ligne de fuite.

CONSEILS POUR LE JOINTOIEMENT

Faites attention dans le choix des mastics pour les joints ; vérifiez les fiches techniques, choisissez-le si possible ton sur ton et respectez scrupuleusement les temps de nettoyage conseillés dans la mesure où différents mastics colorés de nouvelle génération contiennent des pigments et d'additifs qui peuvent s'avérer particulièrement tenaces. Pour les surfaces polies, n'utilisez pas de mastics époxy ou de mortiers flexibles à base de matériaux synthétiques (Flexfughe) et n'ajoutez pas d'additifs/éléments lactiques au mastic, dans la mesure où ils rendent extrêmement difficile l'élimination des résidus avec les produits de nettoyage normaux. Si vous décidez de les utiliser malgré tout, nous vous recommandons de toujours effectuer un essai préalable en dehors de l'ouvrage.

TRADITIONNELLE BODENVERLEGUNG

Die Verlegung von **MAXFINE** - Platten erfordert ähnliche Bedingungen wie jene von Platten traditionellen Formats. **MAXFINE** erfordert die Anwendung der Technik des doppelten Auftragens; das heißt, der Klebstoff wird sowohl auf den Untergrund als auch auf die Unterseite der Platte aufgetragen. Für die Bodenverlegung erfordert **MAXFINE** die besten Untergrundbedingungen:

- Ebenheit;
- Keinerlei Staub, Schutt oder Zementklumpen;
- Die zu verlegende Fläche muss homogen sein und keine Restfeuchte verzeichnen;
- Reparatur eventueller Risse;
- Niveauunterschiede müssen mit entsprechenden Ausgleichsmitteln geebnet werden.

Notwendige Werkzeugausrüstung

- Klebstoff in Pulverform, auf Zementbasis im Vollbett der Klasse "C2E laut der Normen EN 12004 und S1 sowie der Norm EN 12002"
- Spachtel mit quadratischen Zacken, 3x3mm, und Spachtel mit runden Zacken, 15mm;
- Gestell mit Saugnäpfen oder Doppel-Saugnapfe
- Prallfester Kunststoffhammer, 170x370 mm;
- Planierungssystem: Grundelement + Keil + Zange.

Bearbeitungsphasen

AUFTRAGEN DES KLEBSTOFFS AUF DEM BODEN

- 1) Sicherstellen, dass die zu verlegende Bodenfläche robust, eben, staub- und fettfrei ist.
- 2) Die oben beschriebenen Klebstoffe gemäß der, auf dem Etikett des gewählten Klebstoffs angegebenen Zusammenstellung mischen und anwenden.
- 3) Den Klebstoff auf die zu verlegende Fläche mittels des Spachtels mit runden 15 mm-Zacken auftragen, auf eine Fläche, die 5/10 cm größer ist als die der Platte selbst.
- 4) Die Platte mit dem Gestell mit Saugnäpfen in senkrechte Position bringen und den Klebstoff, mittels des Spachtels mit quadratischen 3x3mm-Zacken, auf die Unterseite auftragen.
- 5) Mittels des Gestells mit Saugnäpfen die Platte in waagrechte Position bringen und verlegen.
- 6) Um das gleichmäßige Verlegen der Platte zu garantieren, muss der prallfeste Kunststoffhammer 170x370 mm verwendet werden, indem man von der Mitte der Platte aus in Richtung Ränder klopft, um eventuelle Luftblasen zwischen der Unterseite der Platte, dem Klebstoff und dem Boden zu beseitigen.
- 7) Das Planierungssystem anwenden.

PLANIERUNGSSYSTEM

Das Planierungssystem soll schnell und einfach perfekt geebnete Böden garantieren, indem es Niveauunterschiede ("Zacken") zwischen den Platten beseitigt. Das Planierungssystem wird für die Verlegung von **MAXFINE** - Platten wärmstens empfohlen. Notwendige Werkzeugausrüstung

- Grundelement;
- Keil;
- Verstellbare Zange für Installationen an Boden/Wandverkleidungen.

Anwendung des Planierungssystems

Positionierung des Grundelementes:

- a) Nachdem der Klebstoff aufgetragen wurde, das Grundelement über der Platte, entsprechend der 4 Seiten, anbringen.
- b) Je nach Format der Platte, ein oder mehrere Träger auf jeder Seite der Platte anbringen.
- c) Die Platte positionieren.

Anbringen des Keils:

- a) Den Keil am Schlitz des Trägers anbringen und dabei Acht geben, nicht über den Bruchpunkt hinaus zu gehen.
- b) Um das Anbringen des Keils zu erleichtern, empfiehlt sich der Gebrauch der, mit Zug verstellbaren Zange.

Entfernen des Trägers:

- a) Sobald der Klebstoff fest ist, wird der hervorstehende Teil des Trägers vom Grundelement getrennt, indem man mit dem Fuß in Richtung der Fugenlinie schlägt.

ALLGEMEINE HINWEISE FÜR DIE VERFUGUNG

Bei der Wahl der Fugendichtstoffe immer sehr vorsichtig sein. Prüfen Sie jeweils die Angaben in den technischen Merkblättern, und bevorzugen Sie Dichtstoffe im gleichen Farbton. Halten Sie sich strengstens an die für die Reinigung vorgegebenen Zeiten, da viele moderne farbige Dichtstoffe Pigmente und Zusatzstoffe enthalten, die besonders hartnäckig sein könnten. Benutzen Sie für die polierten/geschliffenen Oberflächen keine Epoxidstückmaterialien bzw. flexible Mörtel auf synthetischer Materialbasis (Flexfugen) und fügen Sie dem Stück weder Zusatzstoffe noch Latex hinzu, da ansonsten eventuelle Rückstände nur sehr schwer mit herkömmlichen Reinigungsmitteln entfernt werden können. Sollte man diese Materialien jedoch trotzdem einsetzen, ist es empfehlenswert, zuerst einen Test an einer nicht sichtbaren Stelle durchzuführen.

PULIZIA E MANUTENZIONE

Premessa_Tutti i materiali FMG sono di facile pulizia e di semplice manutenzione. Una pulizia adeguata ne valorizza le caratteristiche estetiche donando ad ogni pavimento un'eccezionale brillantezza.

Pulizia iniziale_È di basilare importanza e deve essere effettuata immediatamente dopo la posa, per eliminare completamente i residui cementizi derivanti dalle malte, i residui di collanti e i residui epossidici che possono provenire dalle fughe. Viene consigliato l'uso di un prodotto acido, tipo DETERDEK a concentrazione 1:5.

Strofinare energicamente e, dopo la pulizia, risciacquare abbondantemente con acqua pulita, per asportare tutte le tracce del detergente utilizzato.

Queste operazioni sono indispensabili per tutte le collezioni FMG.

Manutenzione e cura_Grazie al procedimento produttivo impiegato (alte temperature di cottura, materie prime di qualità e processo di sinterizzazione) la superficie dei materiali FMG è praticamente impermeabile (assorbimento d'acqua minimo). Pertanto anche la sporcizia non può penetrare ma deve soltanto essere asportata dalla superficie del materiale. In questa operazione si sconsiglia di utilizzare detergenti contenenti cere o prodotti ceranti onde evitare la formazione di strati untuosi; per la scelta del detergente più appropriato, fare riferimento ai capitoli seguenti.

Consigli generali_Per grandi superfici soggette a carichi di sporco notevoli, quali aeroporti, ospedali, supermercati e luoghi pubblici ad alta intensità di traffico, si rendono indispensabili macchine per la pulizia con aspirazione dei liquidi di lavaggio. Ciò permetterà di ottenere non solo una pulizia profonda ma anche l'asportazione dei liquidi contenenti la sporcizia: in tal modo viene evitata la formazione di patine o pellicole altrimenti molto difficili da asportare.

Al fine di preservare le superfici dallo sporco e dalle lavorazioni di cantiere, a posa terminata le pavimentazioni, in particolar modo quelle realizzate con materiali levigati, devono essere adeguatamente protette con truciolare o altri materiali idonei. In tal modo sarà possibile evitare danneggiamenti provocati da lavorazioni successive.

Sui materiali FMG possono essere utilizzati tutti i detergenti esistenti sul mercato alla concentrazione indicata; è escluso l'acido fluoridrico (HF) e tutti i suoi composti, come da norma UNI-EN 176. La concentrazione del detergente deve essere sempre la più bassa possibile, sia per contenere i costi che per velocizzare la manutenzione.

Per pavimenti sopraelevati si consigliano prodotti lucidati o levigati in formati grandi in modo da effettuare operazioni di manutenzione a secco, o con un minimo utilizzo di liquidi.

Una volta ultimata la posa in opera è necessario effettuare una pulizia iniziale approfondita della pavimentazione con prodotti idonei.

Materiali naturali_Per questi materiali, dopo aver effettuato le operazioni specificate nella sezione "Pulizia iniziale" è sufficiente una normale manutenzione con una soluzione acquosa contenente piccole percentuali di un detergente alcalino, tipo FILA CLEANER alla concentrazione 1:200.

Per questi tipi di superficie è sconsigliabile eseguire un trattamento impermeabilizzante: non essendoci alcuna porosità, l'impermeabilizzazione si depositerebbe soltanto sulla superficie in modo disomogeneo causando così effetti estetici disarmonici.

CLEANING AND MAINTENANCE

Introduction_All FMG materials are easy to clean and maintain. Regular cleaning highlights the aesthetic features of the material and gives the floor an exceptional shine.

Initial cleaning_The initial cleaning done immediately after the flooring laid is of essential importance for removing all mortar, adhesives and epoxy residues that may be left in the joints. In this initial phase, we recommend that you use an acid product such as DETERDEK, in a 1:5 concentration. Rub energetically to obtain the maximum cleaning. After washing the floor, which is just as important, rinse thoroughly with plenty of water to remove all traces of the detergent used. These steps are recommended for all FMG collections.

Maintenance and care_Thanks to the characteristics of the production process (high firing temperature, raw materials of great quality, sinterizing process), the surface of FMG material is waterproof (the water absorption is minimum). Therefore the dirt cannot penetrate but it is necessary to remove it from the surface. For this procedure do not use detergents containing waxes or waxing products, in order to avoid the forming of greasy layers; for choosing the most appropriate detergent refer to the following chapters. After the installation of floors, particularly of those made with polished materials, the surfaces should be adequately protected with particle board or other suitable materials in order to protect them from dirt and on-site processing. This prevents damage caused by subsequent processing

General recommendations_For commercial and heavily used surface areas such as airports, hospitals, supermarkets, and any public spaces with heavy foottraffic which are thus subject to considerable soiling, it is necessary to use automatic cleaning machines with suction of the washing liquids.

This allows not only deep cleaning, but also the continuous removal of liquids containing substances that cause soiling, thus preventing the formation of films which are very difficult to remove. Any detergent on the market can be used in the desired concentration for cleaning the high technology sinterized FMG products, with the exception of HYDROFLUORIC acid (HF) or its compounds, according to UNI-EN 176 standards. In order to keep costs limited and speed up maintenance operations, the concentration of the detergent must always be as low as possible. For raised floors we suggest to choose bright or polished surfaces in large sizes: these materials can be dry cleaned or with the minimum use of liquids. After the floor is laid it is necessary to make a very accurate initial cleaning with proper products.

Matt materials_For these materials, after completing the steps described in the section "Initial Cleaning", you only need to clean the floor with hot water containing small quantities of an alkaline detergent such as FILA CLEANER in a concentration 1:200.

On these types of surface it is not advisable to apply a waterproofing product: the absence of porosity causes the waterproofing agent to deposit on the surface in an uneven way and to have unpleasant aesthetic effects.

EINIGUNG UND PFLEGE

Einleitung_Alle FMG Materialien sind einfach zu reinigen und pflegeleicht. Eine angemessene Reinigung wertet die ästhetischen Eigenschaften auf und verleiht jedem Boden einen außergewöhnlichen Glanz.

Erste Reinigung_Von entscheidender Bedeutung ist die Anfangsreinigung, die direkt nach dem Verlegen zu erfolgen hat, um aus dem Mörtel stammende Zementrückstände, Klebrückstände sowie Epoxydrückstände der Fugen vollständig zu beseitigen. In dieser Phase wird die Verwendung eines säurehaltigen Produktes empfohlen zum Beispiel DETERDEK in einer Konzentration von 1:5. Für eine gründliche Reinigung muß kräftig geschauert werden. Nach der Reinigung

ist das Spülen mit reichlich Wasser ebenfalls von großer Wichtigkeit, um alle Spuren des verwendeten Reinigungsmittels zu entfernen. Diese Arbeitsgänge sind für alle Kollektionen unverzichtbar.

Wartung und pflege_Dank des angewandten Prouktionsverfahrens (hohe Brenn-temperatur, qualitativ hochwertiges Rohmaterial und Sinterung) ist die Oberfläche der FMG Materialien praktisch völlig wasserabweisend (minimale Feuchtigkeitsaufnahme). Daher kann Schmutz auch nicht in die Oberfläche eindringen, sondern muß nur von der Oberfläche entfernt werden. Es ist davon abzuraten, dafür wachshaltige Reinigungsmittel oder Produkte zum Einwachsen zu verwenden, um die Bildung von öligen Schichten zu vermeiden.

In den nachfolgenden Abschnitten wird näher auf die Auswahl der geeigneten Reinigungsmittels eingegangen. Um die Oberflächen vor Verschmutzungen und Beschädigungen durch Bauarbeiten zu schützen, müssen die Bodenbeläge, insbesondere die aus geschliffenen Materialien, nach der Verlegung entsprechend mit Spanplatten oder anderen geeigneten Materialien abgedeckt werden. Auf diese Weise können Beschädigungen durch spätere Arbeiten vermieden werden.

Allgemeine Hinweise_Für grosse, bedeutende Oberflächen wie Flughäfen, Krankenhäuser, Supermärkte und andere öffentliche Bereiche mit hohem Verkehrsaufkommen, die daher auch einer starken Verschmutzung ausgesetzt sind, ist der Einsatz von automatischen Reinigungsmaschinen mit Absaugung der Reinigungsflüssigkeit unverzichtbar, da sie nicht nur eine tiefe Reinigung erlauben, sondern auch ständig die Flüssigkeit mit dem Schmutz entfernen und so die Bildung von eventuellen Schmutz-oder Schmierfilmen vermeiden, die immer schwer zu entfernen sind.

Auf den FMG Materialien, können alle auf dem Markt befindlichen Reinigungsmittel in der gewünschten Konzentration verwendet werden, mit Ausnahme von Fluorsäure (HF) oder ähnlichen Produkten, gemäss UNI-EN 176.

Die Konzentration des Reinigungsmittels muss aus Gründen der Kosten und der Schnelligkeit der Reinigung stets so gering wie möglich sein. Für die Doppelböden werden grossen Formate in glänzender oder geschliffener Ausführung empfohlen, so, dass eine trockene oder leicht feuchte Pflege ausreichend ist. Nach Abschluss der Verlegearbeit ist es notwendig, mit geeigneten Reinigungsmitteln eine gründliche Anfangsreinigung des Fussbodens durchzuführen.

Matt Materialien_Für diese Materialien ist, nachdem die im Kapitel "Anfangsreinigung" dargelegten Schritte durchgeführt wurden, eine gewöhnliche Wartung mit einer wässrigen Lösung, die einen kleinen Anteil alkalischen Reinigungsmittels (zum Beispiel FILA CLEANER in der Konzentration 1:200) enthält, notwendig. Für diese Arten von Oberfläche ist von einer Wasserfestigkeitsbehandlung abzuraten; da die Oberflächen nicht porös sind, würde eine Wasserfestigkeitsbehandlung nur zu ungleichmässigen Ablagerungen auf der Oberfläche und damit zu einem optisch disharmonischen Eindruck führen.

NETTOYAGE ET ENTRETIEN

Avant-propos_Tous les matériaux FMG sont faciles à nettoyer et à entretenir. Un nettoyage adéquat met en relief les caractéristiques esthétiques, conférant à chaque sol un éclat particulier.



Nettoyage initial_Le nettoyage initial est d'une importance fondamentale et doit s'effectuer immédiatement après la pose pour éliminer totalement les résidus de ciment des mortiers, les résidus de colle et les résidus epoxy provenant des joints. Nous conseillons dans cette phase d'utiliser un produit acide, du type DETERDEK concentré à 1:5. Frottez énergiquement pour obtenir un nettoyage parfait.

Après le lavage, il est également important de rincer abondamment à l'eau claire pour éliminer toutes les traces du détergent utilisé. Ces opérations sont indispensables pour toutes les collections de FMG.

Entretien et soin_Grâce aux caractéristiques du procédé de production (hautes températures de cuisson, matières premières de qualité et procédé de grésage) la surface des matériaux FMG est pratiquement imperméable (l'absorption d'eau est minimum). Cela signifie que la saleté ne peut pas pénétrer mais doit seulement être retirée de la surface du matériau. Pour cette opération on déconseille l'usage des détergents contenant de la cire ou des produits de cirage afin d'éviter la formation de couches de graisse ; pour le choix du détergent le plus approprié, lisez les chapitres suivants. Après avoir achevé la pose des sols, notamment ceux réalisés avec des matériaux polis, appliquer des panneaux de particules ou autres matériaux adéquats pour protéger comme il se doit les surfaces contre la saleté et les résidus de chantier. Il sera ainsi possible d'éviter que les opérations suivantes n'abîment le carrelage.

Conseils généraux_Pour les grandes et importantes surfaces comme les aéroports, les hopitaux, les supermarchés et les lieux publics à circulation très intense et qui par conséquent se salissent beaucoup, il est indispensable d'utiliser des machines automatiques de nettoyage qui aspirent les liquide de lavage. Vous obtiendrez non seulement un nettoyage profond mais vous éliminerez en permanence les liquides contenant les matériaux responsable de saleté et vous éviterez la formation de patine ou de pellicule qui sont toujours très difficiles à éliminer. Vous pouvez utiliser sur les matériaux FMG, produits de haute technologie et grésage, tous les détergents que propose le marché, à la concentration souhaitée, excepté l'acide fluorhydrique (HF) et ses composants, suivant les normes UNIEN 176. La concentration du détergent doit toujours être la plus faible possible pour réduire le coût et activer l'entretien. Pour les faux-planchers nous conseillons, dans les grands formats, les produits lustrés ou polis. En effet, nous recommandons un entretien à sec, ou avec un minimum de liquide. Quand la pose est terminée, il est nécessaire d'effectuer un nettoyage initial très approfondi avec les produits appropriés.

Materiaux non polis_Après avoir effectué les opérations décrites plus haut, un entretien normal suffit à ces matériaux, avec une solution aqueuse contenant un faible pourcentage de détergent alcalin, type FILA CLEANER à des concentration de 1:200 pour ces types de surface ni est pas conseillable de faire un traitement imperméabilisant : vu qu'ils ne sont pas poreuses l'argent imperméabilisant resterait sur la surface et causerait des effets esthétiques non harmonieux.

IMBALLO Cassa di legno PACKAGING Crate in wood		FORMATO lastre in mm FORMAT slabs in mm	PEZZI capienza max ITEMS max capacity	SCATOLE capienza max BOXES max capacity	MQ capienza max SQ.M. max capacity	KG capienza max KG max capacity	NOTE NOTES
	CASSA CON INTERFALDA 300x150: Ingombro: 322 x 163 x h.34 cm Peso: 114 kg Crate with padding layers 300x150: Size: 322 x 163 x 34(H) cm Weight: 114 kg	300x150	12	-	54,00	870,00	- ordine minimo 2 lastre per cassa; - non sono ammessi più di 6 articoli (codici) differenti per cassa; carico su camion: - sovrapposibilità max. su camion n. 6 casse; - max. 24 casse su camion (4 spazi) compatibilmente con i limiti di peso totale; - possibilità di affiancare a ciascuna pila nr. 2 europallet; - minimum order: 2 slabs per crate; - no more than 6 items (codes) per crate allowed; loading on lorry: - stack max. 6 crates on lorry; - max. 24 crates on lorry (4 spaces) within total weight limits; - option of placing 2 euro-pallets next to each stack;
	CASSA CON INTERFALDA 300x100: Ingombro: 324 x 115 x h.37 cm Peso: 100 kg Crate with padding layers 300x100: Size: 324 x 115 x 37(H) cm Weight: 100 kg	300x100	16	-	48,00	776,00	- ordine minimo 3 lastre per cassa; - non sono ammessi più di 6 articoli (codici) differenti per cassa; carico su camion: - sovrapposibilità max. su camion n. 5 casse; - max. 32 casse su camion (8 spazi) compatibilmente con i limiti di peso totale; - possibilità di affiancare le casse l'una all'altra; - minimum order: 3 slabs per crate; - no more than 6 items (codes) per crate allowed; loading on lorry: - stack max. 5 crates on lorry; - max. 32 crates on lorry (8 spaces) within total weight limits; - option of placing crates next to each other;
	CASSA CON INTERFALDA 150x150: Ingombro: 172 x 163 x h.41 cm Peso: 66,5 kg Crate with padding layers 150x150: Size: 172 x 163 x 41(H) cm Weight: 66,5 kg	150x150	24	-	54,00	822,50	- ordine minimo 4 lastre per cassa; - in ciascuna cassa il numero di lastre per articolo deve sempre essere pari; - non sono ammessi più di 6 articoli (codici) differenti per cassa; carico su camion: - sovrapposibilità max. su camion n. 5 casse; - max. 28 casse su camion (7 spazi) compatibilmente con i limiti di peso totale; - possibilità di affiancare a ciascuna pila nr. 1 europallet; - minimum order: 4 slabs per crate; - each crate must always contain an even number of slabs per item; - no more than 6 items (codes) per crate allowed; loading on lorry: - stack max. 5 crates on lorry; - max. 28 crates on lorry (7 spaces) within total weight limits; - option of placing 1 euro-pallet next to each stack;





NOTE

- Il peso di casse e cavalletti è suscettibile di variazioni sensibili in base allo stato di umidità al momento della misurazione del peso;
- carico su camion: l'indicazione del numero massimo di casse è riferito ad un pianale unico di 13,6 x 2,45 m, compatibilmente con il peso; per camion di dimensioni differenti occorre riformulare il calcolo sulla base dello spazio e del volume delle casse;
- Carico su camion: per la sovrapposibilità di casse alte e basse non oltrepassare l'altezza max. del numero di casse alte indicate per ciascun formato;
- Imballo in casse alte / basse / pallet: a parità di articolo (codice) ordinato, le casse vengono via via riempite secondo l'imballo di massima capienza (es: ordine 90 mq articolo XYZ in formato 150x75 cm sarà imballato con nr. 1 cassa alta contenente 58,5 mq + nr. 1 cassa alta per 31,5 mq);
- Reso delle casse: Il cliente avrà la facoltà di restituire le casse addebitate in fattura, franco stabilimento Ariosteaa. Personale autorizzato accerterà lo stato delle casse rese e compilerà il modulo di reso esclusivamente per le casse integre e complete dei quattro dischi metallici (bulldog) posti su ciascun angolo. Non possono essere resi né cavalletti, né pallet.

NOTE

- The weight of the crates and racks is subject to significant variations based on the moisture content at the time the weight was measured;
- Loading on lorry: the specified maximum number of crates refers to a single 13.6 x 2.45 m platform, within weight limits; for lorries of different sizes, calculation must be made based on the space and volume of the crates;
- Loading on lorry: to stack tall and short crates, do not exceed the maximum height for the number of tall crates specified for each format;
- Packaging in pallets/tall/short crates: for the same item (code) ordered, the crates are gradually filled according to the package of maximum capacity (e.g.: an order of 90 sq.m. of item XYZ in format 150 x 75 cm will be packaged in 1 tall crate containing 58.5 sq.m. + 1 tall crate containing 31.5 sq.m.);
- Crate return: the customer will have the option of returning the crates billed on the invoice, ex-factory Ariosteaa. Authorised employees will check the conditions of the returned crates and will fill out the return form, exclusively for undamaged crates that include the four toothed metal discs placed on each corner. Racks and pallets cannot be returned.

IMBALLO Cassa di legno PACKAGING Crate in wood		FORMATO lastre in mm FORMAT slabs in mm	PEZZI capienza max ITEMS max capacity	SCATOLE capienza max BOXES max capacity	MQ capienza max SQ.M. max capacity	KG capienza max KG max capacity	NOTE NOTES
	<p>CASSA ALTA: Ingombro: 172 x 112 x h.65 cm Peso: 72 kg CASSA BASSA: Ingombro: 172 x 112 x h.40 cm Peso: 51 kg</p> <p>TALL CRATE: Size: 172 x 112 x 65(H) cm Weight: 72 kg SHORT CRATE: Size: 172 x 112 x 40(H) cm Weight: 51 kg</p>	<p>150x100 cassa alta tall crate</p> <p>150x100 cassa bassa short crate</p>	<p>40</p> <p>18</p>	<p>40</p> <p>18</p>	<p>60,00</p> <p>27,00</p>	<p>912,00</p> <p>432,00</p>	<p>- ordine minimo 2 scatole (= 2 lastre); - ordine tassativo multipli di 2 lastre / scatole; - una cassa alta / bassa non possono contenere articoli (codici) differenti; carico su camion: - sovrapposibilità max. su camion n. 3 casse alte; - max. 30 casse alte su camion (15 spazi) compatibilmente con i limiti di peso totale;</p> <p>- <i>minimum order: 2 boxes (= 2 slabs);</i> - <i>each crate must always contain an even number of slabs/boxes;</i> - <i>a tall/short crate may not contain different items (codes);</i> loading on lorry: - <i>stack max. 3 tall crates on lorry;</i> - <i>max. 30 tall crates on lorry (15 spaces) within total weight limits;</i></p>
	<p>CASSA ALTA: Ingombro: 172 x 89 x h.65 cm Peso: 57 kg CASSA BASSA: Ingombro: 172 x 89 x h.41 cm Peso: 41 kg</p> <p>TALL CRATE: Size: 172 x 89 x 65(H) cm Weight: 57 kg SHORT CRATE: Size: 172 x 89 x 41(H) cm Weight: 41 kg</p>	<p>150x75 cassa alta tall crate</p> <p>150x75 cassa bassa short crate</p>	<p>52</p> <p>24</p>	<p>26</p> <p>12</p>	<p>58,50</p> <p>27,00</p>	<p>876,00</p> <p>419,00</p>	<p>- ordine minimo 1 scatola (= 2 lastre); - una cassa alta / bassa non possono contenere articoli (codici) differenti; carico su camion: - sovrapposibilità max. su camion n. 3 casse alte; - max. 30 casse alte su camion (15 spazi) compatibilmente con i limiti di peso totale;</p> <p>- <i>minimum order: 1 box (= 2 slabs);</i> - <i>a tall/short crate may not contain different items (codes);</i> loading on lorry: - <i>stack max. 3 tall crates on lorry;</i> - <i>max. 30 tall crates on lorry (15 spaces) within total weight limits;</i></p>
	<p>CASSA ALTA: Ingombro: 172 x 89 x h.65 cm Peso: 57 kg CASSA BASSA: Ingombro: 172 x 89 x h.41 cm Peso: 41 kg</p> <p>TALL CRATE: Size: 172 x 89 x 65(H) cm Weight: 57 kg SHORT CRATE: Size: 172 x 89 x 41(H) cm Weight: 41 kg</p>	<p>75x75 cassa alta tall crate</p> <p>75x75 cassa bassa short crate</p>	<p>114</p> <p>54</p>	<p>38</p> <p>18</p>	<p>64,13</p> <p>30,38</p>	<p>954,82</p> <p>466,32</p>	<p>- ordine minimo 1 scatola (= 3 lastre); - una cassa alta / bassa non possono contenere articoli (codici) differenti; carico su camion: - sovrapposibilità max. su camion n. 3 casse alte; - max. 30 casse alte su camion (15 spazi) compatibilmente con i limiti di peso totale;</p> <p>- <i>minimum order: 1 box (= 3 slabs);</i> - <i>a tall/short crate may not contain different items (codes);</i> loading on lorry: - <i>stack max. 3 tall crates on lorry;</i> - <i>max. 30 tall crates on lorry (15 spaces) within total weight limits;</i></p>
	<p>CASSA ALTA: Ingombro: 172 x 89 x h.65 cm Peso: 57 kg CASSA BASSA: Ingombro: 172 x 89 x h.41 cm Peso: 41 kg</p> <p>Tall crate: Size: 172 x 89 x 65(H) cm Weight: 57 kg Short crate: Size: 172 x 89 x 41(H) cm Weight: 41 kg</p>	<p>75x37,5 cassa alta tall crate</p> <p>75x37,5 cassa bassa short crate</p>	<p>264</p> <p>120</p>	<p>44</p> <p>20</p>	<p>74,25</p> <p>33,75</p>	<p>1096,5</p> <p>513,50</p>	<p>- ordine minimo 1 scatola (= 6 lastre); - una cassa alta / bassa non possono contenere articoli (codici) differenti; carico su camion: - sovrapposibilità max. su camion n. 3 casse alte; - max. 30 casse alte su camion (15 spazi) compatibilmente con i limiti di peso totale;</p> <p>- <i>minimum order: 1 box (= 6 slabs);</i> - <i>a tall/short crate may not contain different items (codes);</i> loading on lorry: - <i>stack max. 3 tall crates on lorry;</i> - <i>max. 30 tall crates on lorry (15 spaces) within total weight limits;</i></p>
	<p>CASSA ALTA: Ingombro: 121 x 112 x h.65 cm Peso: 55 kg CASSA BASSA: Ingombro: 121 x 112 x h.41 cm Peso: 46,5 kg</p> <p>Tall crate: Size: 121 x 112 x 65(H) cm Weight: 55 kg Short crate: Size: 121 x 112 x 41(H) cm Weight: 46.5 kg</p>	<p>100x100 cassa alta tall crate</p> <p>100x100 cassa bassa short crate</p>	<p>52</p> <p>24</p>	<p>26</p> <p>12</p>	<p>52,00</p> <p>24,00</p>	<p>783,50</p> <p>382,50</p>	<p>- ordine minimo 1 scatola (= 2 lastre); - una cassa alta / bassa non possono contenere articoli (codici) differenti; carico su camion: - sovrapposibilità max. su camion n. 3 casse alte; - max. 44 casse alte su camion (22 spazi) compatibilmente con i limiti di peso totale;</p> <p>- <i>minimum order: 1 box (= 2 slabs);</i> - <i>a tall/short crate may not contain different items (codes);</i> loading on lorry: - <i>stack max. 3 tall crates on lorry;</i> - <i>max. 44 tall crates on lorry (22 spaces) within total weight limits;</i></p>

IMBALLO Cassa di legno <i>PACKAGING</i> Crate in wood		FORMATO lastre in mm <i>FORMAT</i> slabs in mm	PEZZI capienza max <i>ITEMS</i> max capacity	SCATOLE capienza max <i>BOXES</i> max capacity	MQ capienza max <i>SQ.M.</i> max capacity	KG capienza max <i>KG</i> max capacity	NOTE <i>NOTES</i>
	CAVALLETTO DA 50 LASTRE: Ingombro: 310 x 74 x h.188 cm Peso: 215 kg <i>Rack for 50 slabs:</i> <i>Size: 310 x 74 x 188(H) cm</i> <i>Weight: 215 kg</i>	300x150 cavalletto 50 lastre <i>rack</i> 50 slabs	50	-	225,00	3366,50	<ul style="list-style-type: none"> - un cavalletto può contenere max. 5 articoli (codici) differenti; - il cavalletto deve essere riempito per la massima capacità indicata; - per ragioni di ottimizzazione spazi, in questo cavalletto possono essere inserite anche 48 lastre (al posto di nr. 2 cavalletti da 24 lastre) <ul style="list-style-type: none"> - one rack may contain up 5 different items (codes); - the rack must be filled to the maximum capacity specified; - in order to optimise space, this rack may be filled with 48 slabs (instead of 2 racks with 24 slabs each)
	300x100 cavalletto 50 lastre <i>rack</i> 50 slabs	50	-	150,00	2316,50		
	CAVALLETTO DA 24 LASTRE: Ingombro: 319 x 71 x h.185 cm Peso: 148 kg <i>Rack for 24 slabs:</i> <i>Size: 319 x 71 x 185(H) cm</i> <i>Weight: 148 kg</i>	300x150 cavalletto 24 lastre <i>rack</i> 24 slabs	24	-	108,00	1660,00	<ul style="list-style-type: none"> - un cavalletto può contenere max. 5 articoli (codici) differenti; - il cavalletto deve essere riempito per la massima capacità indicata; <ul style="list-style-type: none"> - one rack may contain up 5 different items (codes); - the rack must be filled to the maximum capacity specified;
	CAVALLETTO DA 32 LASTRE: Ingombro: 319 x 71 x h.185 cm Peso: 148 kg <i>Rack for 32 slabs:</i> <i>Size: 319 x 71 x 185(H) cm</i> <i>Weight: 148 kg</i>	300x100 cavalletto 32 lastre <i>rack</i> 32 slabs	32	-	96,00	1474,66	<ul style="list-style-type: none"> - un cavalletto può contenere max. 5 articoli (codici) differenti; - il cavalletto deve essere riempito per la massima capacità indicata; <ul style="list-style-type: none"> - one rack may contain up 5 different items (codes); - the rack must be filled to the maximum capacity specified;
	CAVALLETTO DA 48 LASTRE: Ingombro: 160 x 71 x h.185 cm Peso: 85 kg <i>Rack for 48 slabs:</i> <i>Size: 160 x 71 x 185(H) cm</i> <i>Weight: 85 kg</i>	150x150 cavalletto 48 lastre <i>rack</i> 48 slabs	48	-	108,00	1602,00	<ul style="list-style-type: none"> - un cavalletto può contenere max. 5 articoli (codici) differenti; - il cavalletto deve essere riempito per la massima capacità indicata; <ul style="list-style-type: none"> - one rack may contain up 5 different items (codes); - the rack must be filled to the maximum capacity specified;



CONTAINER 40 PIEDI (11,90 x 2,33 x h.2,35 m)*

- nr. 18 casse 300x150;
- nr. 30 casse 300x100 + nr. 5 casse 150x150;
- nr. 30 casse 300x100 + nr. 6 casse alte 75x37,5\75x75\150x75;
- nr. 30 casse 300x100 + nr. 6 casse alte 100x100;
- nr. 30 casse 300x100 + nr.10 casse alte 150x100;
- nr. 35 casse 150x150 (compatibilmente con il peso);

*Per quanto riguarda i formati 100x100 o 75x37,5\75x75\150x75 il calcolo deve tenere conto del peso (non si occupa mai tutto lo spazio a disposizione poichè si eccederebbero i limiti di peso).

40 FOOT CONTAINER (11.90 x 2.33 x 2.35(H) m)*

- 18 crates 300x150;
- 30 crates 300x100 + 5 crates 150x150;
- 30 crates 300x100 + 6 tall crates 75x37.5\75x75\150x75;
- 30 crates 300x100 + 6 tall crates 100x100;
- 30 crates 300x100 + 10 tall crates 150x100;
- 35 tall crates 150x150 (within weight limits);

*concerning the 100x100 or 75x37.5\75x75\150x75 formats, calculation must take weight into account (the space is never completely filled as weight would be exceeded).

CONTAINER 20 PIEDI (5,90 x 2,32 x h. 2,35 m)

- nr. 6 casse 300x150;
- nr. 10 casse 300x100 + nr. 5 casse 150x150;
- nr. 10 casse 300x100 + nr. 10 casse alte150x100;
- nr. 10 casse 300x100 + nr. 6 casse alte 75x37,5\75x75\150x75;
- nr. 10 casse 300x100 + nr.12 casse alte100x100;
- nr. 15 casse 150x150 + nr. 3 casse alte 75x37,5\75x75\150x75;
- nr. 27 casse alte 100x100 (compatibilmente con il peso);
- nr. 18 casse alte 75x37,5\75x75\150x75;
- nr. 18 casse alte150x100.

20 FOOT CONTAINER (5.90 x 2.32 x 2.35(H) m)

- 6 crates 300x150;
- 10 crates 300x100 + 5 crates 150x150;
- 10 crates 300x100 + 10 tall crates 150x100;
- 10 crates 300x100 + 6 tall crates 75x37.5\75x75\150x75;
- 10 crates 300x100 + 12 tall crates 100x100;
- 15 crates 150x150 + 3 tall crates 75x37.5\75x75\150x75;
- 27 tall crates 100x100 (within weight limits);
- 18 tall crates 75x37.5\75x75\150x75;
- 18 tall crates 150x100.

NOTE

Per la **sovrapponibilità di casse alte e basse** della medesima dimensione occorre rispettare il limite di altezza massima della pila pari a 2,10 m, tenendo presente che il carrello elevatore per il carico dei container non può sollevarsi oltre 1,40 m all'interno del container stesso.

NOTE

Concerning the **stackability of tall and short crates** of the same size, the maximum stack height of 2.10 m, should be respected, bearing in mind that the lift truck for loading the container cannot lift above 1.40 m inside the container itself.

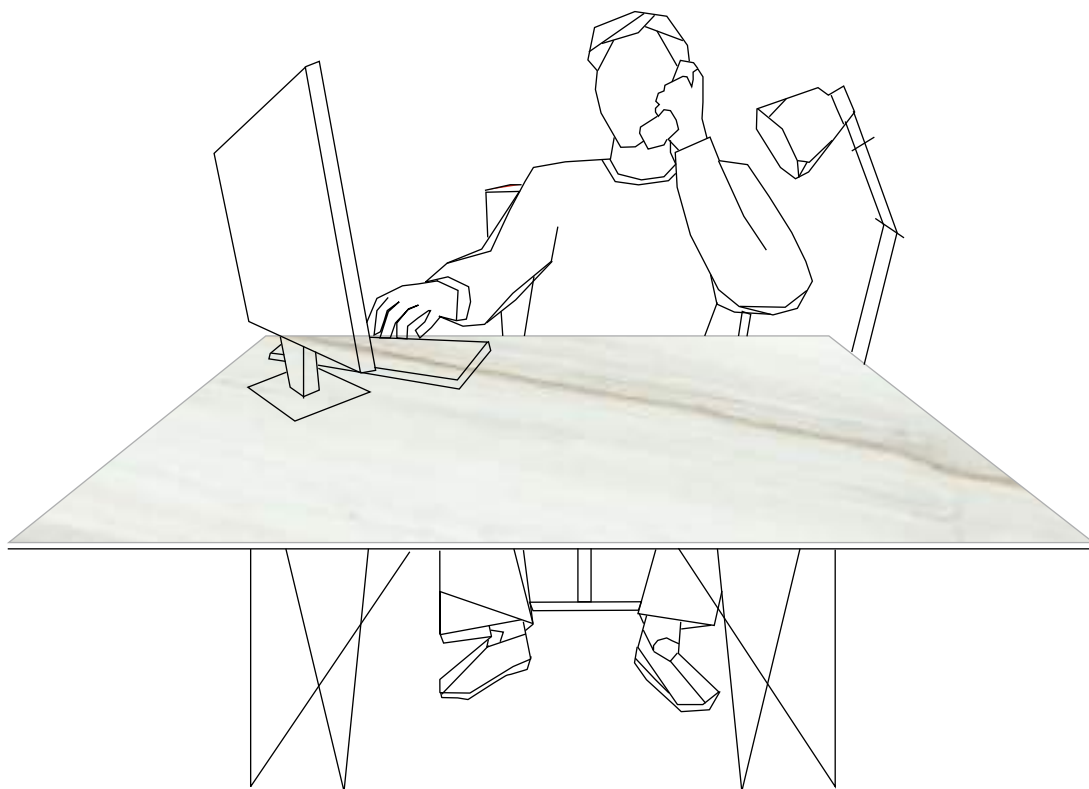

[WEBSITE / IRISFMG.COM](http://www.irisfm.com)

Italiano / English / Deutsch / Français / Español

Sezione MAXFINE:

- catalogo prodotti
- foto gallery realizzazioni
- tutorial movimentazione e posa
- servizi

MAXFINE section:

- catalogue of products
- photo gallery of finished items
- handling and laying tutorial
- services

Section MAXFINE :

- catalogue produits
- photos galerie réalisations
- tutorial sur la manutention et la pose
- services

Sektion MAXFINE:

- Produktkatalog
- Bildergalerie der realisierten Projekte
- Tutorial für Transport und Verlegung
- Dienstleistungen

Oltre alla documentazione cartacea, Iris FMG mette a disposizione una ricca biblioteca online con materiale immediatamente consultabile e scaricabile da qualsiasi dispositivo.

- website
- brochure scaricabili in pdf
- manuali tecnici scaricabili in pdf
- video tutorial
- app

In addition to its printed documentation, Iris FMG places at your disposal a rich on-line library of material that can be consulted immediately and downloaded using any device.

- website
- downloadable pdf brochures
- downloadable pdf technical manuals
- tutorial videos
- apps

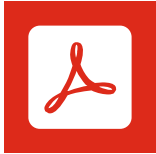

DOWNLOAD

irisfmg.com download area

GENERAL CATALOGUES

- FMG MAXFINE 2018
- IRIS HILITE 2018

SPECIALTIES BROCHURE



Kitchen / Bathroom



Hospitality / Wellness



Indoor / Outdoor furniture



Boat interiors



Wall cladding



TECHNICAL INFO & TUTORIAL HANDBOOK

Manuale tecnico posa e lavorazione

Laying and processing technical manual

Manuel technique pose et mise en œuvre

Technisches Handbuch für Verlegung und Verarbeitung



APP SMARTPHONE / TABLET

IOS - App Store

ANDROID - Google Play



VIRTUAL SHOWROOM

Google maps

Visita virtuale alla showroom

Google maps: Iris Ceramica, Via Ghiarola Nuova, 119
41042 Fiorano Modenese MO

Virtual visit to the showroom

Google maps: Iris Ceramica, Via Ghiarola Nuova, 119
41042 Fiorano Modenese MO

Visite virtuelle du showroom

Google maps: Iris Ceramica, Via Ghiarola Nuova, 119
41042 Fiorano Modenese MO

Virtueller Besuch des Ausstellungsraums

Google maps: Iris Ceramica, Via Ghiarola Nuova, 119
41042 Fiorano Modenese MO



VIDEO TUTORIAL

youtube.com/irisfmg (search: maxfine)

Video tutorial tecnici

Video di prodotto

Technical video tutorials

Product videos

Tutoriels vidéos techniques

Vidéos de produit

Technische Anleitungsvideos

Produktvideos

En plus de sa documentation papier, Iris FMG met à disposition une riche bibliothèque en ligne proposant du matériel pouvant immédiatement être consulté ou téléchargé avec n'importe quel appareil.

- site Internet
- brochures téléchargeables au format PDF
- manuels techniques téléchargeables au format PDF
- tutoriels vidéo
- applis

Außer den Unterlagen auf Papier stellt Iris FMG auch eine reich bestückte Online-Bibliothek zur Verfügung, deren Material Sie sofort ansehen und auf jede Vorrichtung herunterladen können.

- Website
- Broschüre als PDF herunterladen
- Technische Handbücher als PDF herunterladen
- Anleitungsvideos
- App

IDONEITÀ ADESIVI PER LA POSA DI LASTRE MXF A BASSO SPESSORE

					INTERNO - INDOORS								ESTERNO - OUTDOORS			
PRODOTTO Product	LATTICE Latex	CLASSIFICAZIONE Classification			PAVIMENTO - Floors					MURI - Walls				PAVIMENTO - Floors		MURI - Walls
					MASSETTO IN CEMENTO E IN CALCESTRUZZO Cement and concrete screeds	MASSETTI IN ANIDRITE Anhydrite screeds	MASSETTI RISCALDANTI Heated screeds	VECCHIE CERAMICHE, MARMETTE O MATERIALE LAPIDEO Old ceramics, marble-chip floor tiles or stone material	PAVIMENTI IN PVC, LINOLEUM O VINILICI PVC, Linoleum or vinyl flooring	INTONACO CEMENTIZIO, CALCESTRUZZO Cement plaster, concrete	INTONACO IN GESSO Gypsum plaster	CARTONGESSO PANNELLI IN FIBROCEMENTO Plasterboard Fiber cement panels	VECCHIE CERAMICHE Old ceramic	MASSETTO CEMENTIZIO CALCESTRUZZO Cement screed Concrete	VECCHIE CERAMICHE, MARMETTE O MATERIALE LAPIDEO Old ceramics, marble-chip floor tiles or stone material	INTONACO CEMENTIZIO, CALCESTRUZZO Cement plaster concrete
		EN 12004	EN 12002	CM ²					CM ²				CM ²		CM ²	
TECHNOS +	TC - LAX	C2	-	S1	IDONEO <i>Suitable</i>	IDONEO <i>Suitable*</i>	IDONEO <i>Suitable</i>	IDONEO <i>Suitable</i>	-	IDONEO <i>Suitable</i>	IDONEO <i>Suitable*</i>	IDONEO <i>Suitable</i>	IDONEO <i>Suitable</i>	IDONEO <i>Suitable</i>	-	IDONEO <i>Suitable</i>
TECHNOS +	TC LASTIC	C2	-	S2	IDONEO <i>Suitable</i>	IDONEO <i>Suitable*</i>	IDONEO <i>Suitable</i>	IDONEO <i>Suitable</i>	-	IDONEO <i>Suitable</i>	IDONEO <i>Suitable*</i>	IDONEO <i>Suitable</i>	IDONEO <i>Suitable</i>	IDONEO <i>Suitable</i>	-	IDONEO <i>Suitable</i>
TECHNO - XL	TC - LAX	C2	TE	S1	IDONEO <i>Suitable</i>	IDONEO <i>Suitable*</i>	IDONEO <i>Suitable</i>	IDONEO <i>Suitable</i>	-	IDONEO <i>Suitable</i>	IDONEO <i>Suitable*</i>	IDONEO <i>Suitable</i>	IDONEO <i>Suitable</i>	IDONEO <i>Suitable</i>	-	IDONEO <i>Suitable</i>
TECHNO - XL	TC LASTIC	C2	T	S2	IDONEO <i>Suitable</i>	IDONEO <i>Suitable*</i>	IDONEO <i>Suitable</i>	IDONEO <i>Suitable</i>	-	IDONEO <i>Suitable</i>	IDONEO <i>Suitable*</i>	IDONEO <i>Suitable</i>	IDONEO <i>Suitable</i>	IDONEO <i>Suitable</i>	-	IDONEO <i>Suitable</i>
TECHNOLA	TC - LAX	C2	TE	S1	IDONEO <i>Suitable</i>	IDONEO <i>Suitable*</i>	IDONEO <i>Suitable</i>	IDONEO <i>Suitable</i>	-	IDONEO <i>Suitable</i>	IDONEO <i>Suitable*</i>	IDONEO <i>Suitable</i>	IDONEO <i>Suitable</i>	IDONEO <i>Suitable</i>	-	IDONEO <i>Suitable</i>
TECHNOLA	TC LASTIC	C2	TE	S2	IDONEO <i>Suitable</i>	IDONEO <i>Suitable*</i>	IDONEO <i>Suitable</i>	IDONEO <i>Suitable</i>	-	IDONEO <i>Suitable</i>	IDONEO <i>Suitable*</i>	IDONEO <i>Suitable</i>	IDONEO <i>Suitable</i>	IDONEO <i>Suitable</i>	-	IDONEO <i>Suitable</i>
TECHNODUE	-	C2	TE	S1	IDONEO <i>Suitable</i>	IDONEO <i>Suitable*</i>	IDONEO <i>Suitable</i>	IDONEO <i>Suitable</i>	-	IDONEO <i>Suitable</i>	IDONEO <i>Suitable*</i>	IDONEO <i>Suitable</i>	IDONEO <i>Suitable</i>	IDONEO <i>Suitable</i>	-	IDONEO <i>Suitable</i>
TECHNORAP 2	-	C2	FT	S1	IDONEO <i>Suitable</i>	IDONEO <i>Suitable*</i>	IDONEO <i>Suitable</i>	IDONEO <i>Suitable</i>	-	IDONEO <i>Suitable</i>	IDONEO <i>Suitable*</i>	IDONEO <i>Suitable</i>	IDONEO <i>Suitable</i>	IDONEO <i>Suitable</i>	-	IDONEO <i>Suitable</i>
ALL 9000	-	C2	T	-	IDONEO <i>Suitable</i>	IDONEO <i>Suitable</i>	IDONEO <i>Suitable</i>	IDONEO <i>Suitable</i>	IDONEO <i>Suitable</i>	IDONEO <i>Suitable</i>	IDONEO <i>Suitable*</i>	IDONEO <i>Suitable</i>	IDONEO <i>Suitable</i>	IDONEO <i>Suitable</i>	IDONEO <i>Suitable</i>	IDONEO <i>Suitable</i>
TECHNOSTAR/HD	-	C2	TE	S1	≤ 10000	≤ 10000*	≤ 5000	≤ 5000	-	≤ 10000	≤ 10000*	≤ 5000	-	≤ 5000	-	-
AIR-ONE	-	C2	TE	S1	≤ 10000	≤ 10000*	≤ 5000	≤ 5000	-	≤ 10000	≤ 10000*	≤ 5000	-	≤ 5000	-	-
AIRES	-	C2	TE	S2	≤ 10000	≤ 10000*	≤ 5000	≤ 5000	-	≤ 10000	≤ 10000*	≤ 5000	-	≤ 5000	-	-
TECHNOMAX S1	-	C2	E (G)	S1	≤ 10000	≤ 10000*	≤ 5000	≤ 5000	-	-	-	-	-	≤ 5000	-	-

*DOPO UTILIZZO DI "PRIMER T"

LASTRE IN CERAMICA TECNICA CON LE CARATTERISTICHE DEL PORCELLANATO FULL-TECHNICAL CERAMIC SLABS WITH THE CHARACTERISTICS OF PORCELAIN

Classificazione secondo le norme UNI EN 14411 gruppo BIa o ISO 13006 Allegato G gruppo BI a UGL
 Classification in accordance with UNI EN 14411 standards BIa group or ISO 13006 Annex G standards BI a UGL group













* I prodotti con assorbimento < 0,5 sono classificati secondo le norme UNI CEN "Fully vitrified tiles" e secondo le norme ASTM "Impervious tiles"
 The products having an absorption < 0,5 are classified according to the UNI CEN standards "Fully vitrified tiles" and according to the ASTM standards "Impervious tiles"

** Varia secondo la finitura di superficie
 It can vary according to the surface finish

FMG FABBRICA MARMI E GRANITI
 Certificazioni Certifications



See official listing

PROPRIETÀ FISICO-CHIMICHE PHYSICAL-CHEMICAL PROPERTIES	TIPO DI PROVA STANDARD OF TEST	VALORE PRESCRITTO REQUIRED VALUE	VALORE MEDIO MAX/FINE MAX/FINE AVERAGE VALUE
 Dimensioni Sizes	ISO 10545.2	Lunghezza e larghezza Length and width Spessore Thickness Rettilineità spigoli Linearity Ortogonalità Wedging Pianarità Warpage	$\pm 0,6\%$ max $\pm 5\%$ max $\pm 0,5\%$ max $\pm 0,6\%$ max $\pm 0,5\%$ max $\pm 0,1\%$ $\pm 5\%$ $\pm 0,1\%$ $\pm 0,1\%$ $\pm 2\%$
 Assorbimento d'acqua Water absorption	ISO 10545.3	$\leq 0,5\%$	$\geq 0,06\%$ *
 Resistenza alla flessione Flexion resistance	ISO 10545.4	Modulo di rottura Breaking modulus	≥ 35 N/mm ² 53 N/mm ²
 Resistenza all'abrasione profonda Deep abrasion resistance	ISO 10545.6	Volume ≤ 175 mm ³	≤ 142 mm ³
 Coefficiente di dilatazione termica lineare Coefficient of linear thermal-expansion	ISO 10545.8	$\leq 9 \times 10^{-6}$ °C ⁻¹	6 MK ⁻¹
 Resistenza al gelo Frost resistance	ISO 10545.12	Non devono presentare rotture o alterazioni apprezzabili della superficie Must not produce noticeable alteration to surface	Non gelive Frost-proof
 Resistenza ai prodotti chimici Chemical resistance	ISO 10545.13	UB minimum	Conforme Complying with the norm
 Resistenza alle macchie Stain resistance	ISO 10545.14	$1 < X < 5$	CLASSE 5 - CLASS 5 ** Macchie rimosse con acqua corrente calda (senza detergente) Stains removed by hot running water (without detergent)
 Resistenza dei colori alla luce Color resistance to light	DIN 51094	Non devono presentare apprezzabili variazioni di colore Must not produce noticeable colour variation	Campioni inalterati in brillantezza e colore No change in brightness or colour of samples
 Coefficiente di attrito (scivolosità) Friction coefficient (slipperiness)	DIN 51130	Metodo disponibile Test method available	
 Coefficiente di attrito (scivolosità) Friction coefficient (slipperiness)	BCRA REP CEC 6/81	Attrito soddisfacente Satisfactory friction $0,40 \leq \mu \leq 0,74$	$> 0,40$ Superficie naturale Matt surface
 Resistenza al fuoco Fire resistance		96/603/CE	A1



N.B: I valori di resistenza allo scivolamento, coefficiente di attrito statico o dinamico, riportati sul catalogo sono da ritenersi puramente indicativi e non vincolanti. Ogni eventuale specifica necessità dovrà essere da noi confermata al momento dell'ordine e comunque sempre prima della posa.

NB: Slip resistance values, coefficient of static or dynamic friction, in the catalog are purely indicative and not binding. Any specific requirements must be confirmed by us at the time of ordering and in any case before installation.

N.B: Les valeurs de résistance au glissement, le coefficient de frottement statique ou dynamique, indiqués sur le catalogue doivent être considérés comme purement indicatifs et ne sauraient engager notre responsabilité. Toutes les éventuelles spécifications nécessaires devront faire l'objet d'une confirmation de notre part au moment de la commande et en tout état de cause avant la pose.

Anm.: Die Werte für die Rutschfestigkeit, also des statischen oder dynamischen Reibungskoeffizienten, die im Katalog aufgeführt sind, sind als unverbindliche Richtwerte anzusehen. Alle spezifischen Anforderungen müssen von uns bei der Bestellung und in jedem Fall vor der Verlegung immer bestätigt werden.

CARATTERISTICHE TECNICHE ARREDAMENTO-FURNITURE TECHNICAL FEATURES

CARATTERISTICA TECNICA TECHNICAL FEATURE	NORMA O METODO DI MISURA STANDARD OR MEASUREMENT METHOD	VALORE PRESCRITTO DALLE NORME VALUE LAID DOWN BY STANDARDS	VALORE MEDIO MAXFINE; MAXFINE AVERAGE VALUE
 Resistenza superfici al calore umido Surface resistance to wet heat	UNI EN 12721:2013	5 – Nessun cambiamento 5 – No change	5 – Nessun cambiamento riscontrato 5 – No change found
 Resistenza superfici al calore secco Surface resistance to dry heat	UNI EN 12722:2013	5 – Nessun cambiamento 5 – No change	5 – Nessun cambiamento riscontrato 5 – No change found
 Resistenza superfici ai liquidi freddi Surface resistance to cold liquids	UNI EN 12720:2013	5 – Nessun cambiamento 5 – No change	5 – Nessun cambiamento riscontrato 5 – No change found
 Determinazione della tendenza delle superfici a ritenere lo sporco Determination of the tendency of the surface to retain dirt	UNI 9300:1988 + A276:1989	5 – Nessun cambiamento 5 – No change	5 – Nessun cambiamento visibile 5 – No visible change
 Resistenza delle superfici agli sbalzi di temperatura Surface resistance to thermal shock	UNI 9429:1989	5 – Nessun difetto dopo 15 CICLI Length and width	5 – Nessun difetto 5 – No defect
 Determinazione della migrazione globale Determination of overall migration	DM 21/03/1973	Conforme al DM 21/03/1973 Must not produce noticeable alteration to surface	Conforme Compliant
 Resistenza delle superfici ai prodotti di pulizia Surface resistance to cleaning products	PROC. INT. 006/2014	Nessun cambiamento Must not produce noticeable signs of chemical attack	Nessun cambiamento riscontrato No change found

/ edition
2018

FMG FABBRICA
MARMILI E GRANITI

iris

Divisione FMG

Via Ghiarola Nuova, 119 - 41042 Fiorano Modenese (Mo) Italy
tel. +39 0536 862111 fax +39 0536 862452

www.irisfmg.com