

VALVOLE PER GAS BALL VALVES FOR GAS VANNES Á BOISSEAU SPHÉRIQUE POUR GAZ KUGELHÄHNE FÜR GAS VÁLVULAS POR GAS

1. Presentazione

Rubinetterie Bresciane è l'azienda leader nella produzione di valvole a sfera per gas della 4°, 5°, 6° e 7° specie installate prima e dopo il contatore. Le valvole rispondono alla norma Europea EN 331 che regola la costruzione delle valvole a sfera per gas. I brevetti delle serie CLICK-SFER e SICUR-BLOK garantiscono una sicurezza unica contro manovre accidentali e riaperture indesiderate.

1. Introduction

Rubinetterie Bresciane is the leading company in the field of gas ball valve production of 4°, 5°, 6°, 7° family, which are assembled before and after the meter. These valves comply with the European standard EN 331, regulating the manufacturing of gas ball valves. The patents of CLICK-SFER and SICUR-BLOK series warrant a unique safety against unintentional moves as well as undesired reopenings.

1. Présentation

Rubinetterie Bresciane est la société leader pour la production de vannes à boisseau sphérique pour différents genres de gaz, installés avant, avec et après le compteur. Les vannes répondent au normative européenne EN 331 qui régleme la construction des vannes à boisseau sphérique pour gaz. Les brevets du series CLICK-SFER et SICUR-BLOK garantissent une sécurité unique contre manoeuvres accidentelles et réouverturee non désirées.

1. Einführung

Rubinetterie Bresciane ist der führende Hersteller für Gaskugelhähne der 4., 5., 6., und 7. Klasse, die vor, nach bzw. zusammen als Einheit mit dem Gaszähler eingebaut werden. Die Kugelhähne entsprechen der europäischen Norm EN 331, die die Herstellung der Kugelhähne für Gasanwendungen normiert. Die Patente der Serien CLICK-SFER und SICUR-BLOK garantieren eine einzigartige Sicherung gegen unabsichtliche Betätigungen und Wiederöffnungen.

1. Presentación

Rubinetterie Bresciane es la empresa líder por la producción de válvulas esfera por gas de las 4° - 5° - 6° y 7° especie, instaladas antes, con y después el medidor. Las válvulas son conformes a la norma europea EN 331 que regula la construcción de las válvulas esferas por Gas. Las licencias de las series CLICK-SFER y SICUR-BLOCK garantizan una seguridad absoluta contra maniobras incidentales y abieturas indeseadas.

2. Caratteristiche e vantaggi

- Passaggio totale della sfera che permette un'altissima portata con una bassissima perdita di carico.
- Passaggio del fluido nei due sensi (se non diversamente indicato) e quindi possibilità di montare la valvola in qualsiasi posizione.
- Asta montata dall'interno con sistema antiespulsione, secondo le più rigide normative internazionali, per garantire elevati standard di sicurezza.
- Tripla tenuta sull'asta per garantire la tenuta a qualsiasi pressione e temperatura di utilizzo della valvola.
- Profilo della sede sfera brevettata, che garantisce una grande affidabilità e resistenza nel tempo oltre a caratterizzare la valvola con una manovra molto delicata.
- Garantita dalle approvazioni dei più importanti istituti di certificazione internazionali.

2. Features and advantages

- Full bore, allows a huge flow rate and an extremely low loss of load.
- Flow in both direction (if not differently specified), therefore the valves may be mounted in all positions.
- Anti blow-out stem mounting according to the strongest international standards in order for high safety guarantee.
- Triple stem seats to grant tightness at any working pressure and temperature.
- Patented seat profile in order to enable high reliability and long-life together with smooth torque.
- Guaranteed with approvals of the leading international certification institutes.

2. Caractéristiques et avantages

- Passage total du sphère, qui permet une haute porte avec une basse perte de charge.
- Passage du fluide dans les deux sens (si pas autrement indiqué) et en conséquence, possibilité de monter la vanne à n'importe quel position.
- La tige est assemblée par l'intérieur avec un système antiexpulsion, selon les plus rigides directives internationales, pour garantir un niveau de sécurité très élevé.
- Triple tenue sur la tige pour garantir la tenue à toute les pressions et températures d'usage de la vanne.
- Le profil de siège sphère breveté qui garantie une grande précision et résistance longtemps au-delà d'une manoeuvre très douce.
- La vanne est garantie par les approbations des plus importants instituts de certification international.

2. Eigenschaften und Vorteile

- Voller Durchgang der Kugel wodurch eine hohe Durchflussleistung erreicht wird mit einem sehr geringem Druckverlust.
- Durchflussrichtung beliebig (falls nicht anders angegeben) und daher ist die Einbaulage frei wählbar.
- Ausblässichere Spindelkonstruktion gemäss den strengen internationalen Vorschriften um einen hohen Sicherheitsstandard zu garantieren.
- Die dreifache Spindelabdichtung gewährleistet bei unterschiedlichsten Druck- und Temperaturverhältnisse ein hohes Mass an Dichtigkeit.
- Das patentierte Profil des Kugelsitzes garantiert eine hohe Zuverlässigkeit, Lebensdauer und niedrige Drehmomente.
- Die Armatur ist zugelassen durch die namhaftesten internationalen Zulassungsinstitute.

2. Características y ventajas

- Paso total de la esfera que permite un caudal altísimo con una pérdida de carga muy baja.
- Paso del fluido en los dos sentidos (si no diversamente indicado) y pues, posibilidad de armar la válvula en cualquiera posición.
- Vástago ensamblado al interior con sistema contra expulsión, cumpliendo con las más estrictas reglamentaciones internacionales, por garantizar elevados estándar de seguridad.
- Tripla hermeticidad en el vástago por garantizar la misma en la válvula a cualquiera temperatura y / o presión de uso.
- Perfil de la sede esfera patentada. El mismo garantiza una grande fiabilidad y resistencia en el tiempo. Además permite una maniobra muy simple.
- Garantida y aprobada por los más importantes institutos de aprobaciones internacionales.

3. Campi d'impiego

Le valvole a sfera per gas di Rubinetterie Bresciane possono essere utilizzate per gas della 4°, 5°, 6° e 7° specie.

- Temperatura minima e massima di utilizzo: -20°C +60°C (MOT-20).
- Pressione di esercizio massima: 5 bar (MOP5).

3. Working conditions

The gas ball valves of Rubinetterie Bresciane may be used for gas installations of the 4th, 5th, 6th and 7th class.

- The minimum and maximum working temperatures are from -20°C up to +60°C (MOT-20).
- The maximum working pressure is 5 bar (MOP5).

3. Champs d'emploi

Les Vannes à boisseau sphérique pour Gaz de Rubinetterie Bresciane peuvent être utilisées pour différentes genres du gaz.

- Température d'utilisation: minimum -20°C, maximum +60°C (MOT-20).
- La Pression d'exercice est de 5 bar (MOP5).

3. Anwendungsbereiche

Die Gaskugelhähne von Rubinetterie Bresciane dürfen für Gasanwendungen der Klassen 4, 5, 6 und 7 eingesetzt werden.

- Die minimal und maximal Einsatztemperatur ist -20°C bis +60°C (MOT-20).
- Der maximale Betriebsdruck beträgt 5 Bar (MOP 5).

3. Aplicaciones

Las válvulas esferas por gas de Rubinetterie Bresciane se pueden utilizar por gas de la 4° - 5° - 6° y 7° especies.





- Las temperaturas mínimas y máximas de uso son -20°C e +60°C (MOT-20).
- La presión máxima d'ejercicio es 5 bar (MOP5).



serie FIDO-SFER

Art. 9000



-  Valvola a sfera per gas a passaggio totale, filettatura F/F, con farfalla in alluminio.
-  Full bore ball valve for gas, F/F threaded, with aluminium T-handle.
-  Robinet à boisseau sphérique à passage total pour gaz taraudée F/F, avec poignée à papillon en aluminium.
-  Kugelhahn mit vollem Durchgang für Gas, beiderseits Innengewinde mit Aluminiumgriff.
-  Válvula esfera por gas, paso total, roscas hembra/hembra, con mariposa de aluminio.

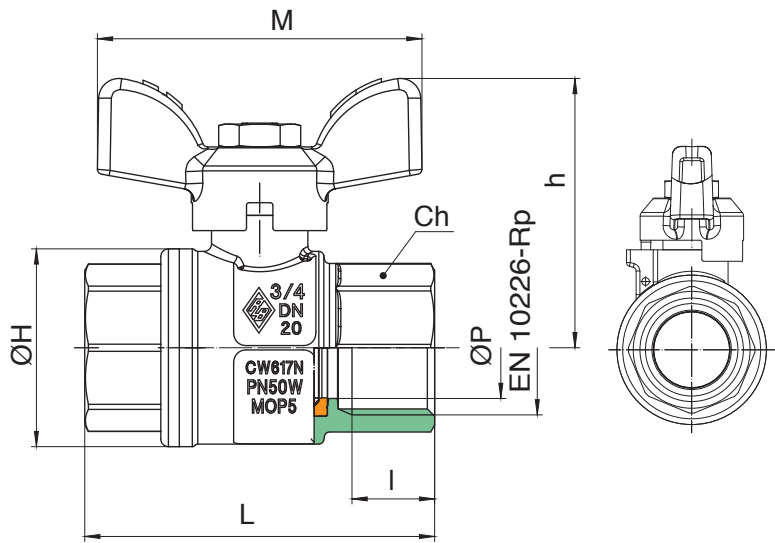
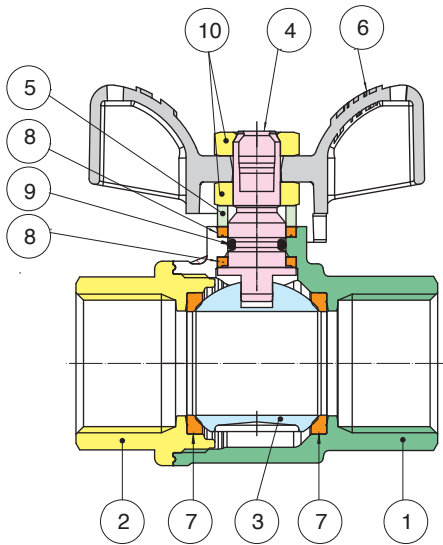

POS.	DENOMINAZIONE	PART NAME	DESCRIPTION	TEILBENENNUNG	DENOMINACION	MATERIALE-MATERIALS MATERIAUX-WERKSTOFF- MATERIAL	N°P
1	CORPO	BODY	CORPS	GEHÄUSE	CUERPO	OTTONE CW617N UNI EN 12165	1
2	MANICOTTO	END CONNECTION	MANCHON	MUFFE	MANGUITO	OTTONE CW617N UNI EN 12165	1
3	SFERA	BALL	BILLE	KUGEL	ESFERA	OTTONE CW617N UNI EN 12165	1
4	ASTA	STEM	TIGE	SPINDEL	EJE	OTTONE CW614N UNI EN 12164	1
5	BUSSOLA PREMIGUARNIZ.	PACKING GLAND	BAGUE DE PRESSE ETOUPE	VORSPANNRING	ANILLO PRENSAESTOPA	OTTONE CW614N UNI EN 12164	1
6	FARFALLA	T-HANDLE	POIGNÉE A PAPILLON	GRIFF	MARIPOSA	ALLUMINIO EN-AC 46100 EN 1706	1
7	GUARNIZIONE SFERA	BALL SEAT	JOINT DE TENUE BILLE	KUGELDICHTUNG	JUNTA ESFERA	P.T.F.E	2
9	O-RING	O-RING	O-RING	O-RING	O-RING	NBR	1
8	GUARNIZIONE ANTIATTRITO	STEM SEAL/THRUST WASHER	JOINT DE L'AXE/ANTIFRICTION	ASIEN TO EJE / ANTI-FRICCIÓN	JUNTA EJE/ANTIFRICCIÓN	P.T.F.E	2
10	DADO	NUT	ECROU	MUTTER	TUERCA	ACCIAIO CL 04	2

MISURA SIZE	DN	BOX	MASTER BOX	CODICE CODE	ØP	I	L	ØH	Ch	M	h	MOP	Kg
1/4"	8	25	50	9000020000	10	11	51,5	23	20	50	37,5	5	0,14
3/8"	10	25	50	9000030000	10	11,4	51,5	23	20	50	37,5	5	0,12
1/2"	15	50	100	9000040000	15	15	62	33	25	50	41	5	0,19
3/4"	20	25	50	9000050000	20	16,3	69	39	31	64	53	5	0,32
1"	25	20	40	9000060000	25	19,1	83	49	38	64	57	5	0,50

Limiti di temperatura: -20°C +60°C - Temperature range: -20°C +60°C.

Disponibili accessori, artt. 96T0-9602-97K0, a pag. 138 - The accessories, item 96T0-9602-97K0, are available. See at page 138.

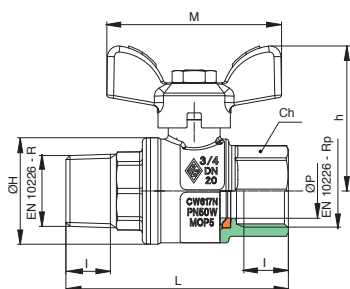
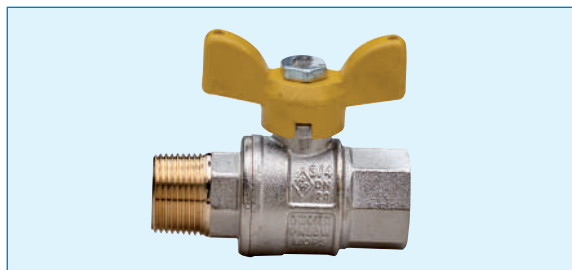

Art. 9001

- Valvola a sfera per gas a passaggio totale, filettatura M/F, con farfalla in alluminio.
- Full bore ball valve for gas, M/F threaded, with aluminium T-handle.
- Robinet à boisseau sphérique à passage total pour gaz taraudée M/F, avec poignée à papillon en aluminium.
- Kugelhahn mit vollem Durchgang für Gas, IG/AG mit Aluminiumgriff.
- Válvula esfera por gas, paso total, roscas macho/hembra, con mariposa de aluminio.

MISURA SIZE	DN	BOX	MASTER BOX	CODICE CODE	ØP	I	L	ØH	Ch	M	h	MOP	Kg
1/4"	8	25	50	9001020000	10	11	59	23	20	50	37,5	5	0,13
3/8"	10	25	50	9001030000	10	11,4	59,5	23	20	50	37,5	5	0,13
1/2"	15	50	100	9001040000	15	15	72,5	33	25	50	41	5	0,21
3/4"	20	25	50	9001050000	20	16,3	81,5	39	31	64	53	5	0,35
1"	25	15	30	9001060000	25	19,1	94,5	49	38	64	57	5	0,53

Limiti di temperatura: -20°C +60°C - Temperature range: -20°C +60°C.

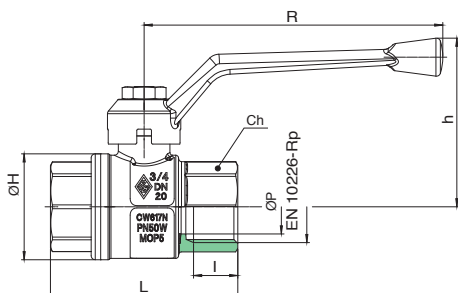

Art. 9010

- Valvola a sfera per gas a passaggio totale, filettatura F/F, con leva in alluminio.
- Full bore ball valve for gas, F/F threaded, with aluminium handle.
- Robinet à boisseau sphérique à passage total pour gaz taraudée F/F, avec poignée en aluminium.
- Kugelhahn mit vollem Durchgang für Gas, beiderseits Innengewinde mit Aluminiumhebel.
- Válvula esfera por gas, paso total, roscas hembra/hembra, con palanca de aluminio.

MISURA SIZE	DN	BOX	MASTER BOX	CODICE CODE	ØP	I	L	ØH	Ch	R	h	MOP	Kg
1/4"	8	25	50	9010020000	10	11	51,5	23	20	95	46,5	5	0,14
3/8"	10	25	50	9010030000	10	11,4	51,5	23	20	95	46,5	5	0,12
1/2"	15	50	100	9010040000	15	15	62	33	25	95	50	5	0,20
3/4"	20	25	50	9010050000	20	16,3	69	39	31	110	62	5	0,33
1"	25	20	40	9010060000	25	19,1	83	49	38	110	66	5	0,51
1 1/4"	32	10	20	9010070000	32	21,4	96	59	48	160	79	5	0,84
1 1/2"	40	6	12	9010080000	40	21,4	108	73	54	160	85,5	5	1,24
2"	50	4	8	9010100000	50	25,7	127	86	67	170	103	5	1,96
2 1/2"	65	2	4	9010120000	65	30,2	152	111	90	205	129	5	3,65
3"	80	-	4	9010140000	80	33,3	177	136	105	205	140	5	5,87
4"	100	-	2	9010180000	100	39,3	214	166	130	260	160	5	10,49

Limiti di temperatura: -20°C +60°C - Temperature range: -20°C +60°C.

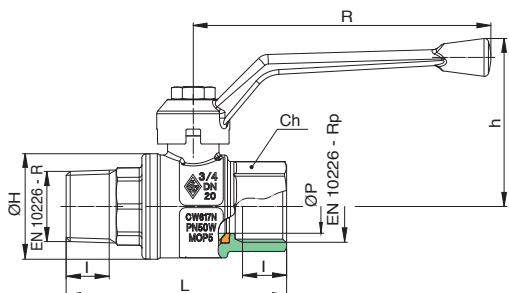

Art. 9011

- Valvola a sfera per gas a passaggio totale, filettatura M/F, con leva in alluminio.
- Full bore ball valve for gas, M/F threaded, with aluminium handle.
- Robinet à boisseau sphérique à passage total pour gaz taraudée M/F, avec poignée en aluminium.
- Kugelhahn mit vollem Durchgang für Gas, IG/AG mit Aluminiumhebel.
- Válvula esfera por gas, paso total, roscas macho/hembra, con palanca de aluminio.

MISURA SIZE	DN	BOX	MASTER BOX	CODICE CODE	ØP	I	L	ØH	Ch	R	h	MOP	Kg
1/4"	8	25	50	9011020000	10	11	59	23	20	95	46,5	5	0,14
3/8"	10	25	50	9011030000	10	11,4	59,5	23	20	95	46,5	5	0,14
1/2"	15	35	70	9011040000	15	15	72,5	33	25	95	50	5	0,21
3/4"	20	25	50	9011050000	20	16,3	81,5	39	31	110	62	5	0,36
1"	25	15	30	9011060000	25	19,1	94,5	49	38	110	66	5	0,54
1 1/4"	32	10	20	9011070000	32	21,4	111	59	48	160	79	5	0,91
1 1/2"	40	6	12	9011080000	40	21,4	119	73	54	160	85,5	5	1,27
2"	50	4	8	9011100000	50	25,7	141,5	86	67	170	103	5	2,03
2 1/2"	65	2	4	9011120000	65	30,2	175	111	90	205	129	5	4,05
3"	80	-	4	9011140000	80	33,3	203,5	136	105	205	140	5	6,27
4"	100	-	2	9011180000	100	39,3	250	166	130	260	160	5	11,79

Limiti di temperatura: -20°C +60°C - Temperature range: -20°C +60°C.

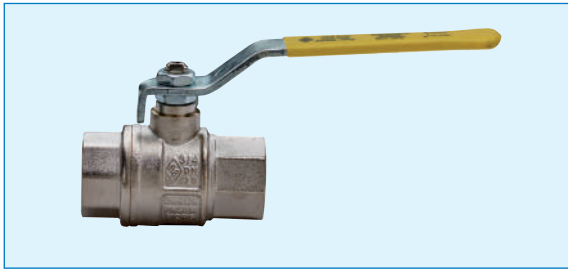

Art. 5980

- Valvola a sfera per gas a passaggio totale, filettatura F/F, con leva in acciaio gialla.
- Full bore ball valve for gas, F/F threaded, with yellow steel handle.
- Robinet à boisseau sphérique à passage total pour gaz, taraudée F/F, avec poignée en acier jaune.
- Kugelhahn mit vollem Durchgang für Gas, beiderseits Innengewinde mit gelbem Stahlhebel.
- Válvula esfera por gas, paso total, roscas hembra/hembra, con palanca de hierro amarilla.

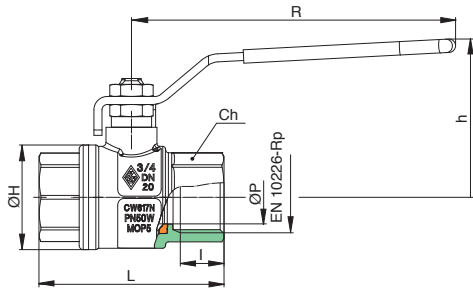

MISURA SIZE	DN	BOX	MASTER BOX	CODICE CODE	ØP	I	L	ØH	Ch	R	h	MOP	Kg
1/4"	8	25	50	5980020000	10	11	51,5	23	20	95	43	5	0,15
3/8"	10	25	50	5980030000	10	11,4	51,5	23	20	95	43	5	0,14
1/2"	15	50	100	5980040000	15	15	62	33	25	95	47	5	0,21
3/4"	20	25	50	5980050000	20	16,3	69	39	31	120	59	5	0,36
1"	25	20	40	5980060000	25	19,1	83	49	38	120	63	5	0,53
1"1/4	32	10	20	5980070000	32	21,4	96	59	48	150	76	5	0,89
1"1/2	40	6	12	5980080000	40	21,4	108	73	54	150	82	5	1,29
2"	50	4	8	5980100000	50	25,7	127,5	86	67	160	95	5	2,00
2"1/2	65	2	4	5980120000	65	30,2	152	111	90	205	122	5	3,73
3"	80	-	4	5980140000	80	33,3	177	136	105	205	133	5	5,95
4"	100	-	2	5980180000	100	39,3	214	166	130	260	166	5	10,57

Limiti di temperatura: -20°C +60°C - Temperature range: -20°C +60°C.



Art. 5981

- Valvola a sfera per gas a passaggio totale, filettatura M/F, con leva in acciaio gialla.
- Full bore ball valve for gas, M/F threaded, with yellow steel handle.
- Robinet à boisseau sphérique à passage total pour gaz, taraudée M/F, avec poignée en acier jaune.
- Kugelhahn mit vollem Durchgang für Gas, IG/AG mit gelbem Stahlhebel.
- Válvula esfera por gas, paso total, roscas macho/hembra, con palanca de hierro amarilla.

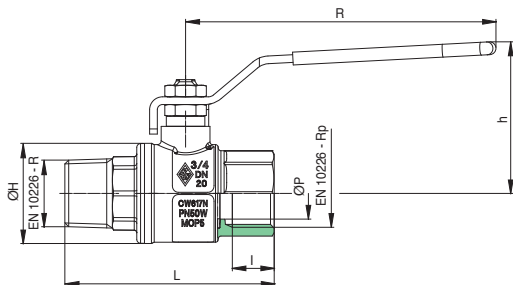

MISURA SIZE	DN	BOX	MASTER BOX	CODICE CODE	ØP	I	L	ØH	Ch	R	h	MOP	Kg
1/4"	8	25	50	5981020000	10	11	59	23	20	95	43	5	0,15
3/8"	10	25	50	5981030000	10	11,4	59,5	23	20	95	43	5	0,15
1/2"	15	35	70	5981040000	15	15	72,5	33	25	95	47	5	0,23
3/4"	20	25	50	5981050000	20	16,3	81,5	39	31	120	59	5	0,39
1"	25	15	30	5981060000	25	19,1	94,5	49	38	120	63	5	0,57
1"1/4	32	10	20	5981070000	32	21,4	111	59	48	150	76	5	0,97
1"1/2	40	6	12	5981080000	40	21,4	119	73	54	150	82	5	1,33
2"	50	4	8	5981100000	50	25,7	141,5	87	67	160	95	5	2,06
2"1/2"	65	2	4	9011120000	65	30,2	175	111	90	205	129	5	4,19
3"	80	-	4	9011140000	80	33,3	203,5	136	105	205	140	5	6,15
4"	100	-	2	9011180000	100	39,3	250	166	130	260	160	5	11,20

Limiti di temperatura: -20°C +60°C - Temperature range: -20°C +60°C.

* Art. 9011



Art. 9040

- Valvola a sfera per gas a passaggio totale, filettatura femmina con raccordo per contatore gas e farfalla in alluminio.
- Full bore ball valve for gas, female threaded and gas meter connection, with aluminium T-handle.
- Robinet à boisseau sphérique à passage total pour gaz taraudée femelle, avec raccord pour compteur à gaz et poignée à papillon en aluminium.
- Kugelhahn mit vollem Durchgang für Gas, Innengewinde und Anschluss für Gaszähler, mit Flügelgriff.
- Válvula esfera por gas, paso total, roscas hembra con conexión por medidor gas y mariposa de aluminio.

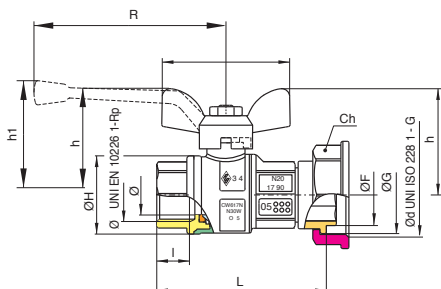

ØD x Ød	BOX	MASTER BOX	CODICE CODE	ØP	ØF	ØG	ØH	M	I	R	h	h1	L	Ch	MOP	Kg
3/4" x 1"1/4"	20	40	9040280000	20	31	39,5	39	64	16,3	-	53	-	85	46	5	0,50
1" x 1"1/4"	10	20	9040290000	25	31	39,5	49	64	19,1	-	57	-	102	46	5	0,70
*1"1/2 x 2"	4	8	9040690000	40	46	57	73	-	21,4	160	-	85	130	63	5	1,82
*2" x 2"1/2"	2	4	9040700000	50	59	72,5	87	-	25,7	170	-	103	151	80	5	2,67

Limiti di temperatura: -20°C +60°C - Temperature range: -20°C +60°C.

* Versione con leva in alluminio - Version with aluminium handle.

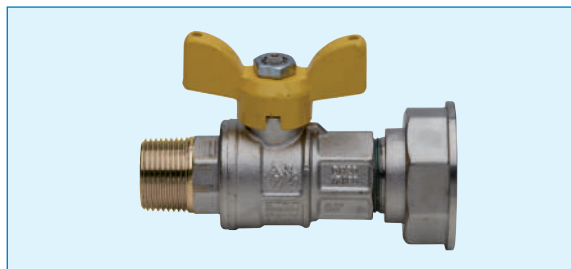

Art. 9041

- Valvola a sfera per gas a passaggio totale, filettatura maschio con raccordo per contatore gas e farfalla in alluminio.
- Full bore ball valve for gas, male threaded and gas meter connection, with aluminium T-handle.
- Robinet à boisseau sphérique à passage total pour gaz taraudée mâle, avec raccord pour compteur à gaz et poignée à papillon en aluminium.
- Kugelhahn mit vollem Durchgang für Gas, Außengewinde und Anschluss für Gaszähler, mit Flügelgriff.
- Válvula esfera por gas, paso total, roscas macho con conexión por medidor gas y mariposa de aluminio.

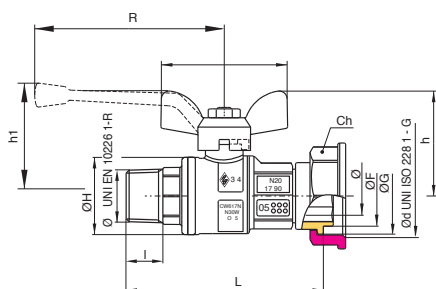

ØD x Ød	BOX	MASTER BOX	CODICE CODE	ØP	ØF	ØG	I	R	h	h1	L	M	ØH	Ch	MOP	Kg
3/4" x 1"1/4	20	40	9041280000	20	31	39,5	16,3	-	53	-	98	64	39	46	5	0,53
1" x 1"1/4	10	20	9041290000	25	31	39,5	19,1	-	57	-	114	64	49	46	5	0,74
**1"1/4 x 1"1/4	10	20	9041070000	25	31	39,5	21,4	-	57	-	102	64	49	63	5	0,72
*2" x 2"	4	8	9041100000	40	46	57	21,4	160	-	85,5	143	-	73	63	5	1,80
*2" 1/2 x 2"1/2	2	4	9041120000	50	59	72,5	25,7	170	-	104	163	-	87	80	5	2,91

Limiti di temperatura: -20°C +60°C - Temperature range: -20°C +60°C.

* Versione con leva in alluminio - Version with aluminium handle.

** La misura da 1"1/4 ha il corpo maschio e il manicotto femmina - The 1"1/4 size has male threaded body and female threaded end connection.



Art. 9068

- Valvola a sfera per gas a passaggio totale, a squadra, filettatura F/F, con farfalla in alluminio.
- Angle full bore ball valve for gas, F/F threaded and aluminium T-handle.
- Robinet à boisseau sphérique pour gaz à passage total, à équerre, taraudée F/F, avec poignée à papillon en aluminium.
- Eck-Kugelhahn mit vollem Durchgang für Gas, beiderseits Innengewinde mit Aluminiumgriff.
- Válvula esfera por gas, paso total angular, roscas hembra/hembra, con mariposa dealuminio.

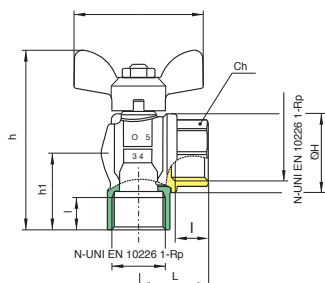

MISURA SIZE	DN	BOX	MASTER BOX	CODICE CODE	I	L	ØH	h	h1	Ch	M	MOP	Kg
1/2"	15	30	60	9068040000	15	31	33	76	34	26	50	5	0,27
3/4"	20	20	40	9068050000	16,3	34,5	39	89	38	31	64	5	0,41
1"	25	15	30	9068060000	19,1	42	49	100	45,5	38	64	5	0,73

Limiti di temperatura: -20°C +60°C - Temperature range: -20°C +60°C.



Art. 9070

- Valvola a sfera per gas a passaggio totale, a squadra, filettatura femmina, con raccordo per contatore gas e farfalla in alluminio.
- Angle full bore ball valve for gas, female threaded and gas meter connection, with aluminium T-handle.
- Robinet à boisseau sphérique pour gaz à passage total, taraudée femelle, à équerre, avec raccord pour compteur à gaz et poignée à papillon en aluminium.
- Eck-Kugelhahn mit vollem Durchgang für Gas, Innengewinde und Anschluss für Gaszähler mit Aluminiumgriff.
- Válvula esfera por gas, paso total angular, roscas hembra con conexión por medidor gas, con mariposa de aluminio.

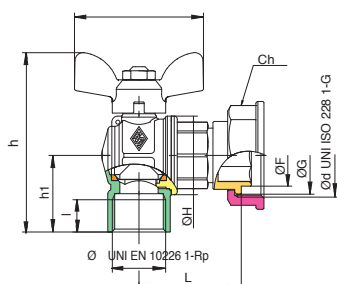

ØD x Ød	BOX	MASTER BOX	CODICE CODE	I	L	h	h1	Ch	ØH	ØF	ØG	M	MOP	Kg
3/4" x 1"1/4	15	30	9070280000	16,3	51	89	38	46	39	30,5	38,5	64	5	0,59
1" x 1"1/4	10	20	9070290000	19,1	63	100	45,5	46	49	30,5	38,5	64	5	0,94

Limiti di temperatura: -20°C +60°C - Temperature range: -20°C +60°C.

serie FIDO-SFER

Art. 6273



- Valvola a sfera per gas a passaggio totale, filettatura F/F, con leva in acciaio gialla.
- Full bore ball valve for gas, F/F threaded, with yellow steel handle.
- Robinet à boisseau sphérique à passage total pour gaz, F/F, avec poignée en acier jaune.
- Kugelhahn mit vollem Durchgang für Gas, beiderseits Innengewinde mit gelbem Stahlhebel.
- Válvula esfera por gas, paso total, roscas hembra/hembra, con palanca de hierro amarilla.

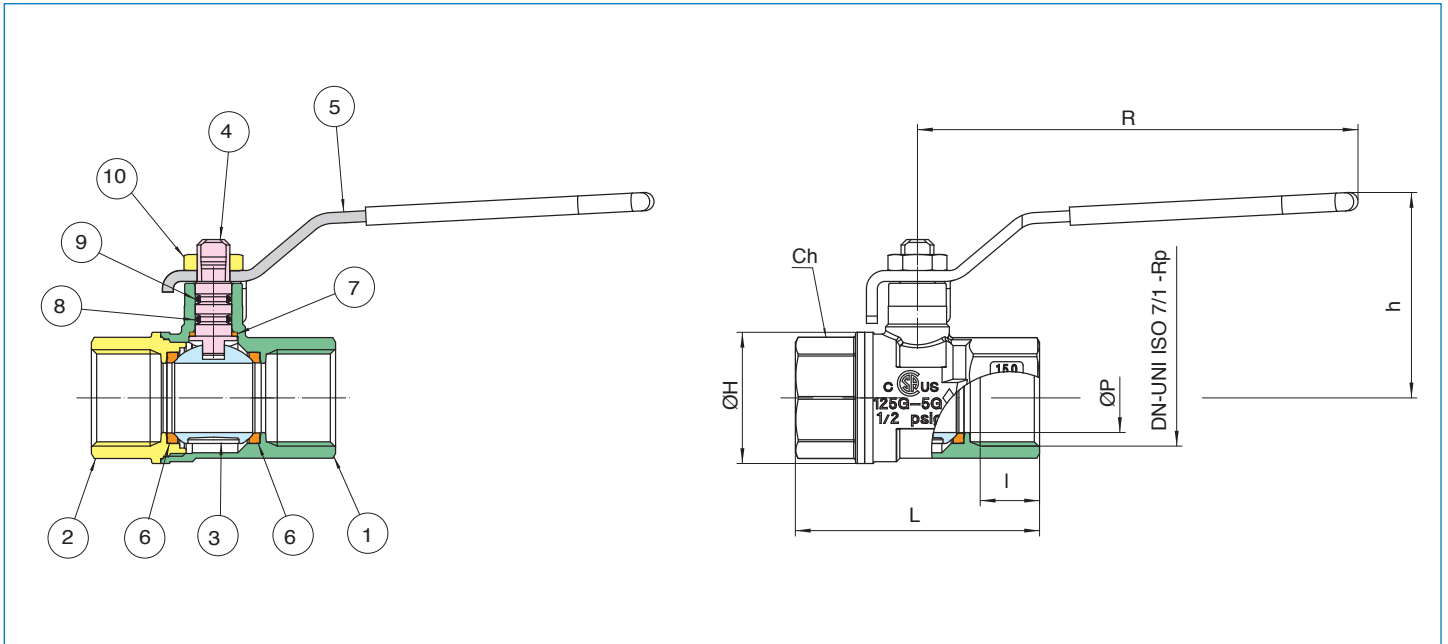

POS.	DENOMINAZIONE	PART NAME	DESCRIPTION	TEILBENENNUNG	DENOMINACION	MATERIALE-MATERIALS MATERIAUX-WERKSTOFF- MATERIAL	N°P
1	CORPO	BODY	CORPS	GEHÄUSE	CUERPO	OTTONE CW617N UNI EN 12165	1
2	MANICOTTO	END CONNECTION	MANCHON	MUFFE	MANGUITO	OTTONE CW617N UNI EN 12165	1
3	SFERA	BALL	BILLE	KUGEL	ESFERA	OTTONE CW617N UNI EN 12165	1
4	ASTA	STEM	TIGE	SPINDEL	EJE	OTTONE CW614N UNI EN 12164	1
5	LEVA	HANDLE	PIOGNÉE	HANDHENEL	PALANCA	ACCIAIO DD11	1
6	GUARNIZIONE SFERA	BALL SEAT	JOINT DE TENUE BILLE	KUGELDICHTUNG	JUNTA ESFERA	P.T.F.E	2
7	GUARNIZIONE ANTIATTRITO	STEM SEAL/THRUST WASHER	JOINT DE L'AXE/ANTIFRICTION	ASIENTO EJE / ANTIFRICCIÓN	JUNTA EJE/ANTIFRIFRICCIÓN	P.T.F.E	1
8	O-RING	O-RING	O-RING	O-RING	O-RING	NBR	1
9	O-RING	O-RING	O-RING	O-RING	O-RING	FKM	1
10	DADO	NUT	ECROU	MUTTER	TUERCA	ACCIAIO CL 04	1





MISURA SIZE	DN	BOX	MASTER BOX	CODICE CODE	I	L	ØH	Ch	R	h	MOP	Kg
1/4**	8	25	50	5980020000	11	51,5	23	20	95	47,5	5	0,14
3/8**	10	25	50	5980030000	11,4	51,5	23	20	95	47,5	5	0,12
1/2"	15	50	100	6273040000	15	59	30	25	96	46	5	0,18
3/4"	20	25	50	6273050000	16,3	67	36	31	121	57	5	0,30
1"	25	20	40	6273060000	19,1	81,5	43,5	38	121	59	5	0,44
1"1/4	32	10	20	6273070000	21,4	94	53	48	151	73	5	0,77
1"1/2	40	6	12	6273080000	21,4	102,5	65	54	151	79	5	1,03
2"	50	4	8	6273100000	25,7	123	80	67	160	93,5	5	1,76
2"1/2*	65	2	4	5980120000	30,2	152	111	90	205	129	5	3,71
3**	80	-	4	5980140000	33,3	177	136	105	205	140	5	5,85
4**	100	-	2	5980180000	39,3	214	166	130	260	160	5	10,20

Limiti di temperatura: -20°C +60°C - Temperature range: -20°C +60°C.

* Art. 5980



Art. 6274

-  Valvola a sfera per gas a passaggio totale, filettatura M/F, con leva in acciaio gialla.
-  Full bore ball valve for gas, M/F threaded, with yellow steel handle.
-  Robinet à boisseau sphérique à passage total pour gaz, M/F, avec poignée en acier jaune.
-  Kugelhahn mit vollem Durchgang für Gas, IG/AG mit gelbem Stahlhebel.
-  Válvula esfera por gas, paso total, roscas macho/hembra, con palanca de hierro amarilla.

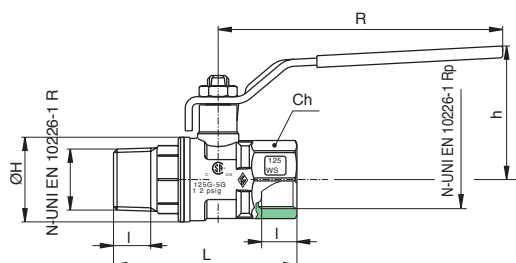





MISURA SIZE	DN	BOX	MASTER BOX	CODICE CODE	I	L	ØH	Ch	R	h	MOP	Kg
1/4**	8	25	50	5981020000	11	59	23	20	95	47,5	5	0,13
3/8**	10	25	50	5981030000	11,4	59,5	23	20	95	47,5	5	0,14
1/2**	15	35	70	6274040000	15	68,7	30	25	96	45	5	0,18
3/4**	20	25	50	6274050000	16,3	75	36	31	121	56,5	5	0,30
1"	25	15	30	6274060000	19,1	92,2	43,5	38	121	59	5	0,44
1 1/4	32	10	20	6274070000	21,4	107	53	48	151	72,5	5	0,77
1 1/2	40	6	12	6274080000	21,4	117,5	65	54	151	78,5	5	1,03
2"	50	4	8	6274100000	25,7	137	80	67	160	91,5	5	1,76
2 1/2**	65	2	4	9011120000	30,2	175	111	90	205	129	5	4,19
3**	80	-	4	9011140000	33,3	203,5	136	105	205	140	5	6,15
4**	100	-	2	9011180000	39,3	250	166	130	260	160	5	11,20

Limiti di temperatura: -20°C +60°C - Temperature range: -20°C +60°C.

* Art. 5981 - ** Art. 9011



Art. 6275

-  Valvola a sfera per gas a passaggio totale, filettatura F/F, con farfalla in alluminio.
-  Full bore ball valve for gas, F/F threaded, with aluminium T-handle.
-  Robinet à boisseau sphérique à passage total pour gaz taraudée F/F, avec poignée à papillon en aluminium.
-  Kugelhahn mit vollem Durchgang für Gas, beiderseits Innengewinde mit Aluminiumgriff.
-  Válvula esfera por gas, paso total, roscas hembra/hembra, con mariposa de aluminio.

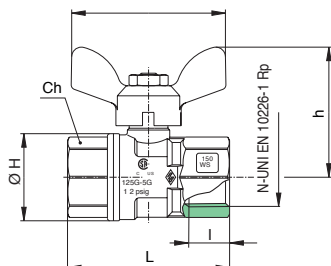



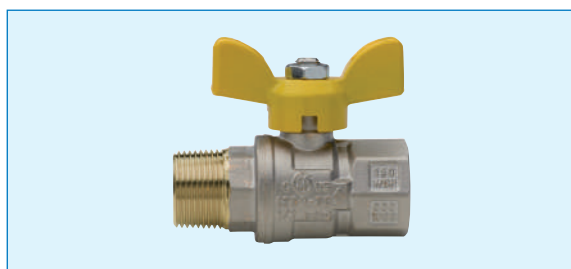

MISURA SIZE	DN	BOX	MASTER BOX	CODICE CODE	I	L	ØH	Ch	M	h	MOP	Kg
1/4**	8	25	50	9000020000	11	51,5	23	20	50	37,5	5	0,14
3/8**	10	25	50	9000030000	11,4	51,5	23	20	50	37,5	5	0,12
1/2"	15	50	100	6275040000	15	59	30	25	50	41	5	0,16
3/4"	20	30	60	6275050000	16,3	67	36	31	64	51	5	0,27
1"	25	20	40	6275060000	19,1	91,5	43,5	38	64	53	5	0,42

Limiti di temperatura: -20°C +60°C - Temperature range: -20°C +60°C.

* Art. 9000



Art. 6276

-  Valvola a sfera per gas a passaggio totale, filettatura M/F, con farfalla in alluminio.
-  Full bore ball valve for gas, M/F threaded, with aluminium T-handle.
-  Robinet à boisseau sphérique à passage total pour gaz taraudée M/F, avec poignée à papillon en aluminium.
-  Kugelhahn mit vollem Durchgang für Gas, IG/AG mit Aluminiumgriff.
-  Válvula esfera por gas, paso total, roscas macho/hembra, con mariposa de aluminio.

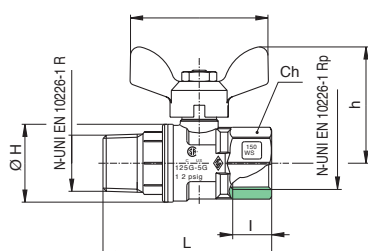

MISURA SIZE	DN	BOX	MASTER BOX	CODICE CODE	I	L	ØH	Ch	M	h	MOP	Kg
1/4**	8	25	50	9001020000	11	59	23	20	50	37,5	5	0,13
3/8**	10	25	50	9001030000	11,4	59,5	23	20	50	37,5	5	0,13
1/2"	15	50	100	6276040000	15	68,7	30	22	50	41	5	0,18
3/4"	20	30	60	6276050000	16,3	78	36	27	64	51	5	0,29
1"	25	20	40	6276060000	19,1	92,2	43,5	34	64	53	5	0,45

Limiti di temperatura: -20°C +60°C - Temperature range: -20°C +60°C.

* Art. 9001

serie FIDO-SFER

Art. 9052

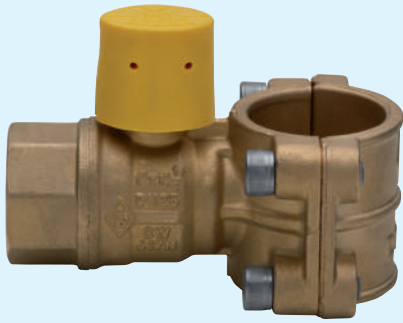

- Valvola a sfera per presa in carico gas a passaggio totale, filettatura femmina con flangia di presa tubo ferro da 1" x 25 a 1"1/2 x 50.
- Full bore gas ball valve for iron rising pipe connection, one side female threaded, sizes 1" x 25 to 1"1/2 x 50.
- Vanne gaz à boisseau sphérique passage total, avec bride pour connections sous pression de gaz, taraudage femelle avec bride de 1" x 25 à 1"1/2 x 50.
- Kugelhahn, voller Durchgang, Innengewinde, für Gasentnahme unter Druck, mit Flansch 1" x 25 bis zu 1"1/2 x 50.
- Válvula esfera paso total, para derivación de gas en presión de tubo montante en hierro, rosca hembra, brida de 1" x 25 a 1"1/2 x 50.

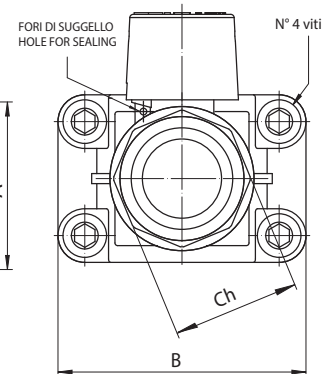
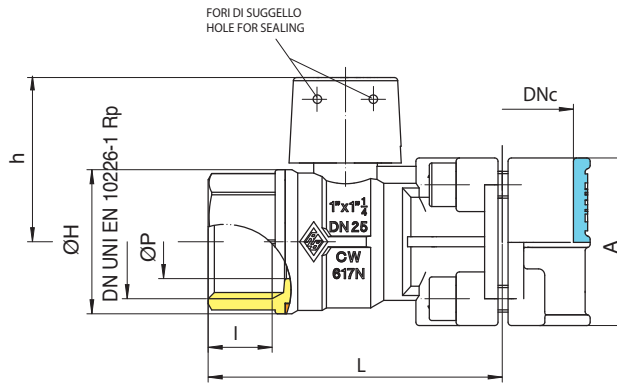
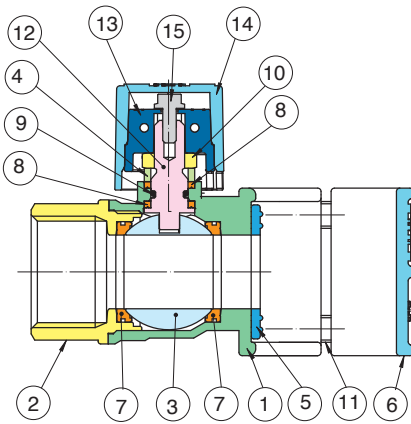

POS.	DENOMINAZIONE	PART NAME	DESCRIPTION	TEILBENENNUNG	DENOMINACION	MATERIALE	N°P
1	CORPO	BODY	CORPS	GEHÄUSE	CUERPO	OTTONE CW617N UNI EN 12165	1
2	MANICOTTO	END CONNECTION	MANCHON	MUFFE	MANGUITO	OTTONE CW617N UNI EN 12165	1
3	SFERA	BALL	BILLE	KUGEL	ESFERA	OTTONE CW617N UNI EN 12165	1
4	BUSSOLA PREMIGUARNIZIONE	PACKING GLAND	BAGUE DE PRESSUREE ETOUPE	VORSPANNRING	ANILLO PRENSAESTOPA	OTTONE CW614N UNI EN 12164	1
5	GUARNIZIONE	SEAL	JOINT	DICHTUNG	AJUNTA	FKM	1
6	SUPPORTO	SUPPORT	SUPPORT	LAGER	SOPORTE	OTTONE CW617N UNI EN 12165	1
7	GUARNIZIONE SFERA	BALL SEAT	JOINT DE TENUE BILLE	KUGELDICHTUNG	JUNTA ESFERA	P.T.F.E	2
8	GUARNIZIONE ANTIATTRITO	STEM SEAL/THRUST WASHER	JOINT DE L'AXE/ANTIFRICTION	STOßHEMME DICHTUNG	JUNTA EJE/ANTIFRIFRICCIÓN	P.T.F.E	2
9	O-RING	O-RING	O-RING	O-RING	O-RING	NBR	1
10	DADO	NUT	ECROU	MUTTER	TUERCA	ACCIAIO CL 04	1
11	VITE	SCREW	VIS	SCHRAUBE	TORNILLO	ACCIAIO INOX A2	4
12	ASTA	STEM	TIGE	SPINDEL	EJE	OTTONE CW614N UNI EN 12164	1
13	CAPPUCCIO PIOMBABILE	CAP	CAPUCHON	KAPPE	CAPUCHO	ZAMA/G Zn A14 ALLOY	1
14	CAPPELOTTO	LOCKABLE CAP	CAPUCHON PLOMBABLE	VERSIEGELUNGSKAPPE	CAPUCHO CERRABLE	PE	1
15	VITE	SCREW	VIS	SCHRAUBE	TORNILLO	ACCIAIO CL 4.8	1

DN x Dnc	DN	BOX	MASTER BOX	CODICE CODE	N°4 viti/screw	I	L	ØH	h	Ch	A	B	MOP	Kg
1" x 25	25	10	20	9052060025	M8 X 25	19,1	83,5	43	55	38	50	64	5	0,76
1" x 32	25	8	16	9052060032	M8 X 25	19,1	88	43	59	38	50	74	5	0,81
1" x 40	25	8	16	9052060040	M8 X 25	19,1	91,5	43	69,5	38	50	84	5	0,90
1"1/2 x 50	40	4	8	9052080050	M8 X 25	21,4	116	73	75,5	54	64	92	5	2,06

Limiti di temperatura: -20°C +60°C - Temperature range: -20°C +60°C.

DERIVAZIONE D'UTENZA IN CARICO – UN'INSTALLAZIONE SICURA E SEMPLICE





SADDLE TAPPING VALVE – A SAFE AND EASY INSTALLATION

DANBOHRKUGELHAHN, ANWENDUNG BEI DRUCK – SICHERE UND EINFACHE INSTALLATION

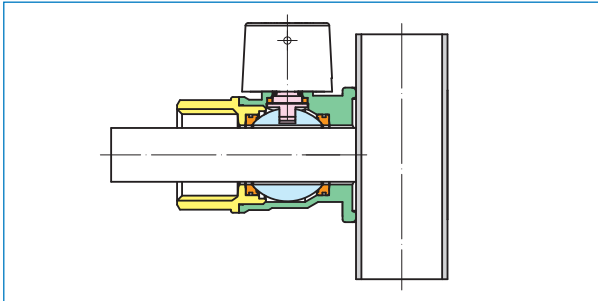



ROBINET DE PRISE EN CHARGE – UNE INSTALLATION SÛRE ET SIMPLE

VALVULA DE TOMA EN CARGO LATERAL – INSTALACION SEGURA Y FÁCIL

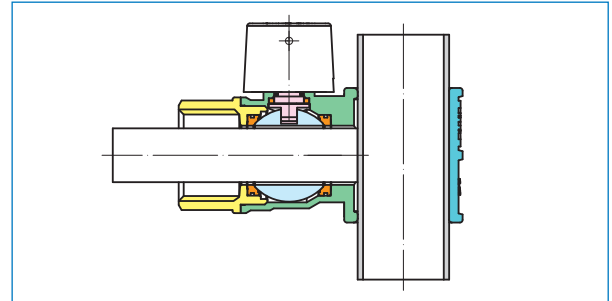





-  Iniziare l'installazione avendo cura di pulire e rendere liscia da asperità o rigature la parte di tubo in ferro dove verrà installata la valvola, in particolare nella zona circostante a ove verrà effettuato il foro, in corrispondenza della zona di contatto con la guarnizione.
-  Start the installation process remembering to clean and smooth the surface of the iron pipe on which the valve will be assembled, especially near the area where the bore will be made.
-  Commencer l'installation, en n'oubliant pas de nettoyer et lisser la surface du tube en fer où la vanne sera installée, en particulier la zone où le trou sera percé, dans la zone de contact du joint.
-  Die Installation vorbereiten durch Reinigung und Anschleifen der Oberfläche des Stahlrohres an der der Kugelhahn montiert wird. Insbesondere im Kontaktbereich der Dichtung.
-  Comenzar la instalación, teniendo cuidado de limpiar y alisar la superficie del tubo en hierro donde se instalará la válvula, en particular, el área donde se hará el agujero, en la zona de contacto de la junta.

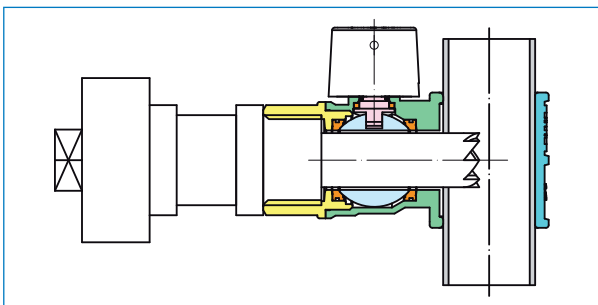





-  Montare la flangia e la valvola sulla tubazione serrando le viti contrapposte in modo che la flangia rimanga parallela al corpo. Durante il montaggio, verificare che la posizione delle guarnizioni rimanga corretta (evitare spostamenti o pieghe).
-  Fit the flange of the valve onto the pipe, tighten the screws opposed to one another in order for the flange to stay parallel to the body. While assembling, verify that the joints' position remains steady (avoid displacements or laps).
-  Installer la bride et la vanne sur le tuyau en serrant les vis en face, en tenant la bride parallèle au corps. Pendant l'installation, vérifier que la position des joints soit correcte (éviter déplacements et plis).
-  Den Flansch und den Kugelhahn auf dem Rohr durch Anziehen der gegenüberliegenden Schrauben montieren, so dass der Flansch parallel zum Körper bleibt. Während der Installation die Einhaltung der richtigen Position der Dichtungen prüfen (Verschiebungen und Faltenbildung verhindern).
-  Montar la brida y la válvula sobre la tubería apretando los tornillos de lo contrario, en manera que la brida esté paralela al cuerpo. Durante la instalación tener controlada la posición correcta de las juntas (evitar el movimiento y los pliegues).

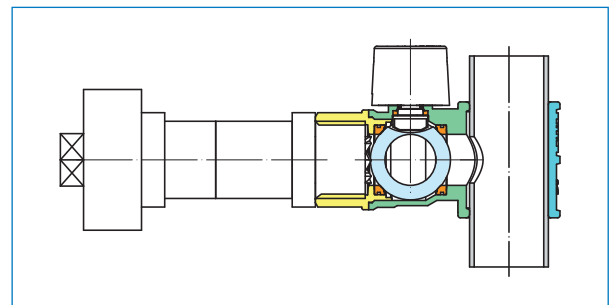

-  Inserire l'attrezzo foratubi avvitandolo sulla valvola, ponendo attenzione che la sfera sia aperta. Facendo ruotare la chiave e la ghiera dell'attrezzatura, procedere con la foratura della tubazione in ferro.
-  Take the drilling machine and screw it onto the valve, paying attention that the ball is open. Turn the key and the ring of the tool, proceed with the boring of the iron pipe.
-  Insérez l'outil de forage en le visseant sur la vanne, en faisant attention que le boisseau sphérique soit ouvert. Tourner la clé et la bague de l'outil et percer le tuyau.
-  Das Bohrwerkzeug am Kugelhahn ansetzen und einschrauben. Sicherstellen, dass der Kugelhahn geöffnet ist. Den Schlüssel und den Ring des Werkzeuges drehen und somit die Stahl Rohrleitung anbohren.
-  Insertar el utillaje de perforación atornillado en la válvula y asegurándose que la esfera está abierta. Girar la llave y el anillo del utillaje haciendo la perforación de la tubería en hierro.







-  A foro eseguito, ritirare la fresa tramite il blocco superiore dell'attrezzatura e chiudere la valvola. Infine smontare l'attrezzatura avendo cura di rimuovere completamente il deposito di lavorazione prima di fissare il tubo di derivazione.
-  Once the boring is done, draw the cutter back through the up-block of the tooling and close the valve. Remove the tooling.
-  Après avoir percé le trou, enlever la pointe de l'outil par le bloc supérieur et fermer la vanne. Enfin, détacher l'outil et éliminer complètement le bavures de l'usinage.
-  Nach der Bohrung des Lochs das Bohrwerkzeug mit dem Oberteil des Gerätes zurückziehen und den Kugelhahn schließen. Schließlich das Werkzeug entfernen und die Rückstände der Bearbeitung entfernen.
-  Una vez que el agujero esta hecho, retirar la punta del utillaje con la parte superior del mismo y cerrar la válvula. Por último, eliminar por completo las rebabas de perforación.

serie FIDO-SFER

Art. 9700

**BREVETTATO
PATENTED**



-  Valvola a sfera per gas, a passaggio totale, filettatura F/F, con blocco di sicurezza per colonna montante gas e cappuccio di protezione.
-  Full bore ball valve for gas rising pipe, F/F threaded, with security lock and protection cap.
-  Robinet à boisseau sphérique à passage total pour gaz, taraudée F/F avec dispositif de sécurité pour colonne montante gaz avec capuchon de protection.
-  Kugelhahn mit vollem Durchgang für Gasrohrleitung, beiderseits Innengewinde, mit Sicherheitschloss und Schutzkappe.
-  Válvula esfera por gas a paso total, roscas hembra/hembra con bloqueo de seguridad por columna gas con capucho cerrable.

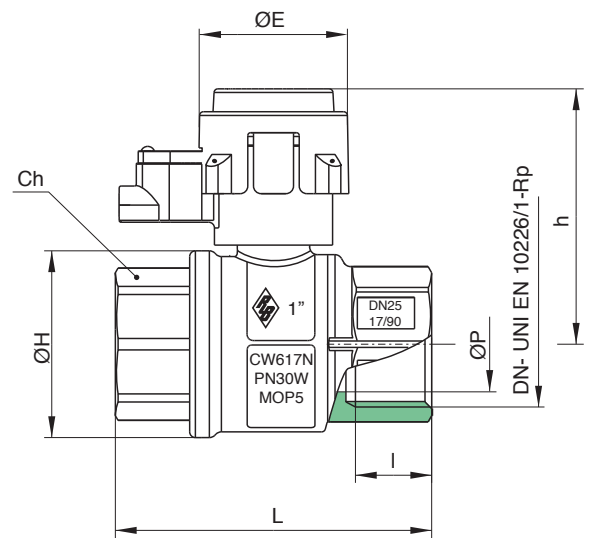
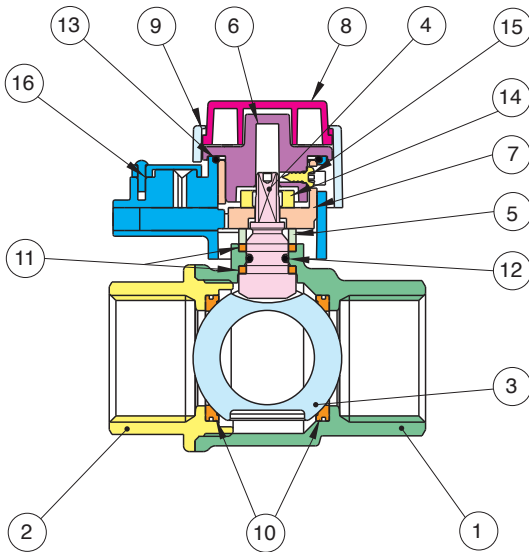

POS.	DENOMINAZIONE	PART NAME	DESCRIPTION	TEILBENENNUNG	DENOMINACION	MATERIALE-MATERIALS MATERIAUX-WERKSTOFF- MATERIAL	N°P
1	CORPO	BODY	CORPS	GEHÄUSE	CUERPO	OTTONE CW617N UNI EN 12165	1
2	MANICOTTO	END CONNECTION	MANCHON	MUFFE	MANGUITO	OTTONE CW617N UNI EN 12165	1
3	SFERA	BALL	BILLE	KUGEL	ESFERA	OTTONE CW617N UNI EN 12165	1
4	ASTA	STEM	TIGE	SPINDEL	EJE	OTTONE CW614N UNI EN 12164	1
5	BUSSOLA PREMIGUARNIZIONE	PACKING GLAND	BAGUE DE PRESSE ETOUPE	VORSPANNRING	ANILLO PRENSAESTOPA	OTTONE CW614N UNI EN 12164	1
6	CAPPUCCIO PIOMBABILE	LOCKABLE CAP	CAPUCHON PLOMBABLE	VERSIEGELUNGSKAPPE	CAPUCHO CERRABLE	ZAMA G Zn Al 4 UNI EN 1774	1
7	COPRI SERRATURA	LOCK PROTECTION	COUVRE-SERRURE	SCHLOSSABDECKUNG	TAPÓN CERRADURA	OTTONE CW614N UNI EN 12164	1
8	CAPPELOTTO	CAP	CAPUCHON	KAPPE	CAPUCHO	ABS	1
9	CAPPELOTTO	CAP	CAPUCHON	KAPPE	CAPUCHO	ABS	1
10	GUARNIZIONE SFERA	BALL SEAT	JOINT DE TENUE BILLE	KUGELDICHTUNG	JUNTA ESFERA	P.T.F.E	2
11	GUARNIZIONE ANTIATTRITO	STEM SEAL/THRUST WASHER	JOINT DE L'AXE/ANTIFRICTION	STOBHEMMENDE DICHTUNG	ASIEN TO EJE/ANTIFRICCIÓN	P.T.F.E	2
12	O-RING	O-RING	O-RING	O-RING	O-RING	NBR	1
13	O-RING	O-RING	O-RING	O-RING	O-RING	NBR	1
14	DADO	NUT	ECROU	MUTTER	TUERCA	ACCIAIO CL 04	1
15	VITE	SCREW	VIS	SCHRAUBE	TORNILLO	ACCIAIO	1
16	SERRATURA	LOCK	SERRURE	SCHLOSS	CERRADURA	ZAMA G Zn Al 4 UNI EN 1774	1

MISURA SIZE	DN	BOX	MASTER BOX	CODICE CODE	ØP	ØE	l	Ch	ØH	L	h	MOP	Kg
1"	25	20	40	9700060000	25	39	19,1	38	49	83	67	5	0,64
1 1/4"	32	10	20	9700070000	32	39	21,4	48	59	96	83	5	1,00
1 1/2"	40	6	12	9700080000	40	39	21,4	54	73	108	89	5	1,54
2"	50	4	8	9700100000	50	39	25,7	67	87	127,5	99	5	2,13





Limiti di temperatura: -20°C +60°C - Temperature range: -20°C +60°C.

Disponibili accessori, artt. 96T0-9602-97K0-5809, a pagg. 138-139 - The accessories, item 96T0-9602-97K0-5809, are available. See at pages 138-139.

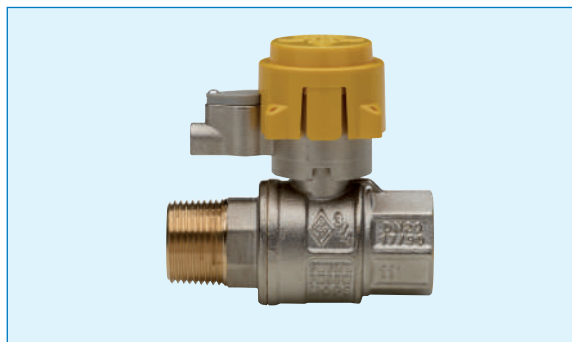
Art. 9701

**BREVETTATO
PATENTED**



-  Valvola a sfera per gas, a passaggio totale, filettatura M/F, con blocco di sicurezza per colonna montante gas e cappuccio di protezione.
-  Full bore ball valve for gas rising pipe, M/F threaded, with security lock and protection cap.
-  Robinet à boisseau sphérique à passage total pour gaz, taraudée M/F avec dispositif de sécurité pour colonne montante gaz avec capuchon de protection.
-  Kugelhahn mit vollem Durchgang für Gasrohrleitung, IG/AG, mit Sicherheitschloss und Schutzkappe.
-  Válvula esfera por gas a paso reducido, roscas macho/hembra con bloqueo de seguridad por columna gas con capucho cerrable.

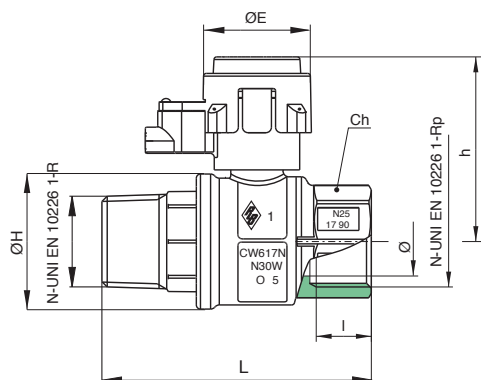

MISURA SIZE	DN	BOX	MASTER BOX	CODICE CODE	ØP	ØE	I	Ch	ØH	L	h	MOP	Kg
1"	25	20	40	9701060000	25	39	19,1	38	49	94,5	67	5	0,67
1"1/4	32	10	20	9701070000	32	39	21,4	48	59	111	83	5	1,07
1"1/2	40	6	12	9701080000	40	39	21,4	54	73	119	89	5	1,58
2"	50	4	8	9701100000	50	39	25,7	67	87	141	99	5	2,18

Limiti di temperatura: -20°C +60°C - Temperature range: -20°C +60°C.

 La valvola a sfera della serie 9700 è dotata di un blocco di sicurezza brevettato che, in caso di chiusura volontaria o accidentale della valvola stessa, impedisce la manovra di riapertura.

L'apertura o riarmo è possibile solo attraverso l'utilizzo di un estrattore di sblocco specifica che viene fornita dal personale abilitato. E' disponibile anche il kit art. 9K70 che permette di trasformare una valvola a sfera per colonna montante (serie 9000), già in esercizio, in una valvola con blocco **SENZA INTERRUPERE** l'erogazione del gas all'utente. Inoltre è possibile la sostituzione del kit in caso di rottura o danneggiamento.

 The ball valve series 9700 is equipped with a patented safety lock that, in case of intentional or accidental closing, avoid its opening.

The opening or riarmo is possible by means of a proper unlocking key only, which is available with the installator.

The kit art. 9K70 is also available and it allows to convert a standard ball valve for rising gas pipe (series 9000), already in use, into a lockable gas valve without **ANY INTERRUPTION** of the gas supply service.

The kit is also replaceable in case of break or damage.

 La vanne à boisseau sphérique du série 9700 est dotée d'un bloc de sécurité Breveté qui, en cas de fermeture volontaire ou accidentelle, prévient la manoeuvre d'ouverture.

L'ouverture est possible seulement à travers l'usage d'une clé spécifique de déblocage, qui vient fournie par le personnel compétent.

C'est aussi disponible le kit, article 9K70, qui permet de transformer une vanne à boisseau sphérique pour colonne montante (série 9000) déjà en service, en une vanne avec bloc, **SANS INTERROMPRE** la distribution de gaz au consommateur.

En autre, c'est possible de remplacer le kit en cas de rupture ou dommage.

 Die Kugelahnserie 9700 ist mit einem patentierten Sicherheitsschloß ausgestattet, um im Falle des gewollten bzw. Ungewollten Schließens, eine Öffnung zu vermeiden. Das Öffnen des Hahnes ist nur möglich mittels eines exakt passenden Schlüssels, der bei dem Installateur erhältlich ist.

Erhältlich ist auch der Umrüstsatz Artikel 9K70, mit dem es möglich ist, einen bereits in der Anwendung befindlichen Gaskugelahn (serie 9000) in einen verschließbaren Hahn umzurüsten. Diese Umrüstung kann erfolgen, ohne die Gaszufuhr in der Rohrleitung zu unterbrechen.

Dieses Montage-Kit kann auch im Falle eines Defekts oder einer Zerstörung ersetzt werden.

 La válvula esfera 9700 es dotada de un sistema de bloqueo de seguridad patentado que, en caso de cierre voluntario o incidental de la misma, impide la maniobra de abertura.

De abertura o rearmado es posible solamente por medio de una llave que esta suministrada solamente de nuestro personal apoderado.

Es disponible también el juego 9K70 que permite de transformar una válvula esfera por columna montante (serie 9000) en una válvula con bloqueo sin parar el suministro de gas al usuario.

Además es posible la substitución de dicho juego en caso se encuentre quebrado y dañado.



serie FIDO-SFER

Art. 6166



- Valvola a sfera per colonna montante gas, con cappuccio piombabile, a passaggio totale, filettatura femmina ed attacco PE, raccordo per tubo di protezione in acciaio.
- Full bore ball valve for gas for riser pipe, with sealable cap, female threaded and PE connection, with fitting for protection steel pipe.
- Robinet à boiseau sphérique pour colonne montante gaz avec capuchon plombable, à passage total, taraudage femelle et connexion PE et raccord pour tuyau de protection en acier.
- Kugelhahn mit vollem Durchgang für Gasrohrleitung, Versiegelungskappe, Innengewinde und PE Anschluss, mit Anschluss für Schutzrohr aus Stahl.
- Válvula esfera por columna d'alimentacion gas, con capucho cerrable a paso total, rosca hembra y conexión PE, racor por el tubo de protección de hierro.

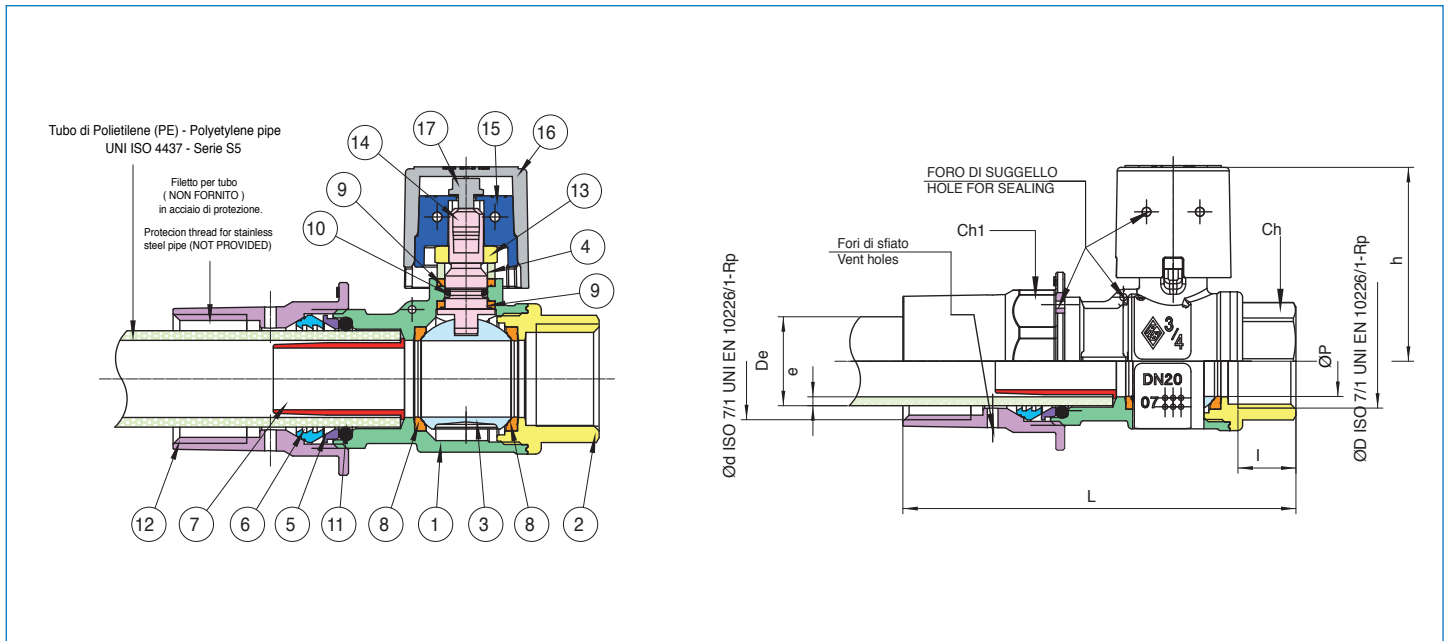

POS.	DENOMINAZIONE	PART NAME	DESCRIPTION	TEILBENENNUNG	DENOMINACION	MATERIALE-MATERIALS MATERIAUX-WERKSTOFF- MATERIAL	N°P
1	CORPO	BODY	CORPS	GEHÄUSE	CUERPO	OTTONE CW617N UNI EN 12165	1
2	MANICOTTO	END CONNECTION	MANCHON	MUFFE	MANGUITO	OTTONE CW617N UNI EN 12165	1
3	SFERA	BALL	BILLE	KUGEL	ESFERA	OTTONE CW617N UNI EN 12165	1
4	BUSSOLA PREMIGUARNIZIONE	PACKING GLAND	BAGUE DE PRESSE ETOUPE	STOFFBUCHSE	ANILLO PRENSAESTOPA	OTTONE CW614N UNI EN 12164	1
5	BUSSOLA PREMIGUARNIZIONE	PACKING GLAND	BAGUE DE PRESSE ETOUPE	STOFFBUCHSE	ANILLO PRENSAESTOPA	OTTONE CW614N UNI EN 12164	1
6	ANELLO ANTI SFILAMENTO	ANTIUNTHREADING RING	BAGUE	SICHERHEITSRING	ANILLO CONTRA DESHILO	OTTONE CW614N UNI EN 12164	1
7	SUPPORTO	SUPPORT	SOUTIEN	VERSTÄRKUNG	SOPORTE	OTTONE CW614N UNI EN 12164	1
8	GUARNIZIONE SFERA	BALL SEAT	JOINT DE TENUE BILLE	KUGELDICHTUNG	JUNTA ESFERA	P.T.F.E	2
9	GUARNIZIONE ANTIATTRITO	ANTIFRICTION SEAT	JOINT ANTI-FRICTION	STOßHEMMENDE DICHTUNG	JUNTA ANTI-FRICCIÓN	P.T.F.E	2
10	O-RING	O-RING	O-RING	O-RING	O-RING	NBR	1
11	O-RING	O-RING	O-RING	O-RING	O-RING	NBR	1
12	DADO	NUT	ECROU	MUTTER	TUERCA	OTTONE CW617N UNI EN 12165	1
13	DADO	NUT	ECROU	MUTTER	TUERCA	OTTONE CW617N UNI EN 12165	1
14	ASTA	STEM	TIGE	SPINDEL	EJE	OTTONE CW614N UNI EN 12164	1
15	CAPPUCCIO PIOMBABILE	LOCKABLE CAP	CAPUCHON PLOMBABLE	VERSIEGELUNGSKAPPE	CAPUCHO CERRABLE	ZAMA/G Zn A14 Alloy UNI 3717	1
16	CAPPELOTTO	CAP	BOUCHON	KAPPE	PROTECCION	PE	1
17	VITE	SCREW	VIS	CSHRAUBE	TORNILLO	ACCIAIO CL 4.8	1





ØD x De	DN	Ød UNI EN 10226-1 Rp	BOX	MASTER BOX	CODICE CODE	ØP	l	e	L	h	Ch	Ch1	MOP	Kg
3/4" x 25	20	1"	15	30	6166050025	20	16,3	2,5	110,5	54,5	31	40	5	0,54
1" x 32	25	1"1/4	10	20	6166060032	25	19,1	3	128	58	38	50	5	0,82
1"1/4 x 40	32	1"1/2	8	16	6166070040	32	21,4	3,7	147,5	69	48	60	5	1,27
1"1/2 x 50	40	2"	6	12	6166080050	40	21,4	4,6	167	75	54	70	5	1,87
2" x 63	50	2"1/2	2	4	6166100063	50	25,7	5,8	194,5	89	67	85	5	2,53

Limiti di temperatura: -20°C +60°C - Temperature range: -20°C +60°C.

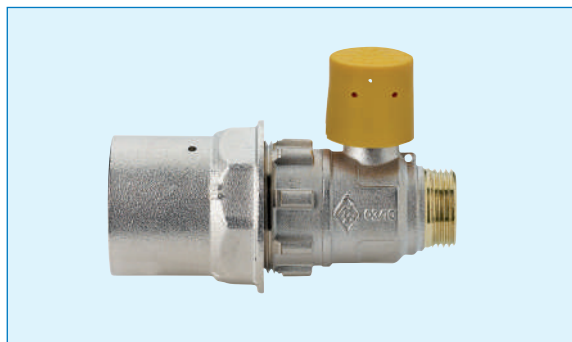
Disponibili accessori, art. 9602-97K0, a pag. 138 - The accessories, item 9602-97K0, are available. See at page 138.

Art. 6277



-  Valvola a sfera per colonna montante gas, con cappuccio piombabile, a passaggio totale, filettatura maschio sfero-conico ed attacco PE, raccordo per tubo di protezione in acciaio.
-  Full bore ball valve for gas for riser pipe, with sealable cap, male threaded and PE connection, with fitting for protection steel pipe.
-  Robinet à boisseau sphérique pour colonne montante gaz avec capuchon plombable, à passage total, taraudage mâle et connexion PE et raccord pour tuyau de protection en acier.
-  Kugelhahn mit vollem Durchgang für Gasrohrleitung, Versiegelungskappe, Außengewinde und PE Anschluss, mit Anschluss für Schutzrohr aus Stahl.
-  Válvula esfera por columna d'alimentación gas, con capucho cerrable a paso total, rosca macho esfero cónico y conexión PE, racor por el tubo de protección de hierro.

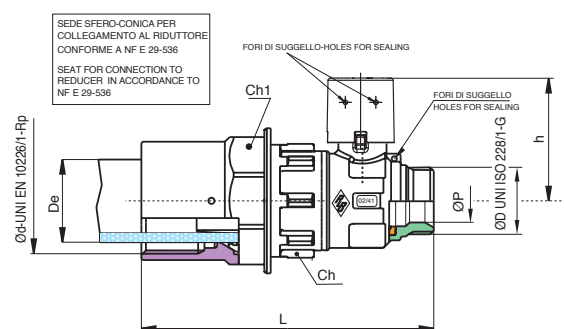



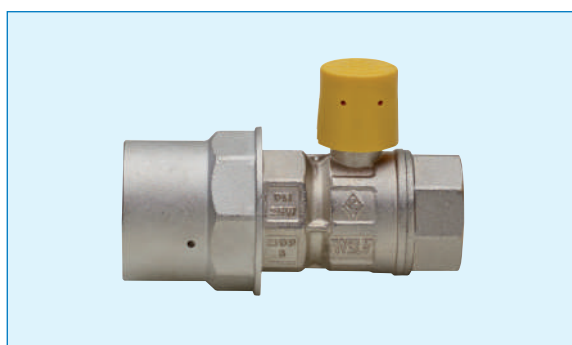

ØD x De	DN	Ød UNI EN 10226-1 Rp	BOX	MASTER BOX	CODICE CODE	ØP	Ch	Ch1	L	h	MOP	Kg
3/4" x 20	20	3/4"	10	20	6277050020	20	29	38	104	47	5	0,47
3/4" x 32	20	1"1/4	10	20	6277050032	20	43	50	115	47	5	0,66
3/4" x 50	20	2"	6	12	6277050050	40	54	70	189	79	5	2,16

Limiti di temperatura: -20°C +60°C - Temperature range: -20°C +60°C.



Art. 6594

-  Valvola a sfera per colonna montante gas, con cappuccio piombabile, passaggio ridotto filettatura femmina ed attacco PE, raccordo per tubo di protezione in acciaio.
-  Reduced bore gas ball valve for riser pipe, with sealable cap, female threaded and PE connection, with fitting for protective steel pipe.
-  Robinet à boisseau sphérique pour colonne montante gaz avec capuchon plombable, passage réduit taraudage femelle et connexion PE, raccord pour tuyau de protection en acier.
-  Kugelhahn für Gasrohrleitung mit Versiegelungskappe, reduzierter Durchgang, Innengewinde und PE-Anschluss und Fitting für Schutzrohr aus Stahl.
-  Válvula esfera para columna de alimentación gas, con capuchón cerrable, rosca hembra y conexión PE, racor para tubo de protección en acero.

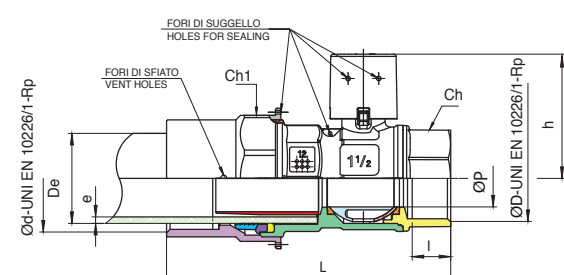





ØD x De	DN	Ød UNI EN 10226-1 Rp	BOX	MASTER BOX	CODICE CODE	ØP	I	Ch	Ch1	L	e	h	MOP	Kg
1" x 32		1"1/4	10	20	6594	20	19,1	38	50	126	3	54,5	5	0,69
1"1/2 x 50		2"	6	12	6594	32	21,4	54	70	158	4,6	69	5	1,47
2" x 63	20	2"1/2	2	2	6594	40	25,7	67	85	187	5,8	75	5	2,38

Limiti di temperatura: -20°C +60°C - Temperature range: -20°C +60°C.



Art. 9044

-  Valvola a sfera per colonna montante gas, a passaggio totale, filettatura F/F, con cappuccio piombabile.
-  Full bore ball valve for gas, F/F threaded and sealable cap.
-  Robinet à boisseau sphérique à passage total pour colonne montante gaz, taraudée F/F avec capuchon plombable.
-  Kugelhahn mit vollem Durchgang für Gas, beiderseits Innengewinde und Versiegelungskappe.
-  Válvula esfera paso por columna alimentación gas, paso total, roscas hembra/hembra con capucho cerrable.

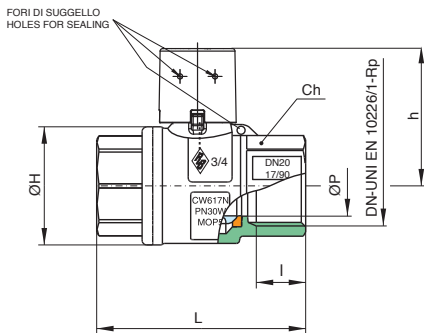



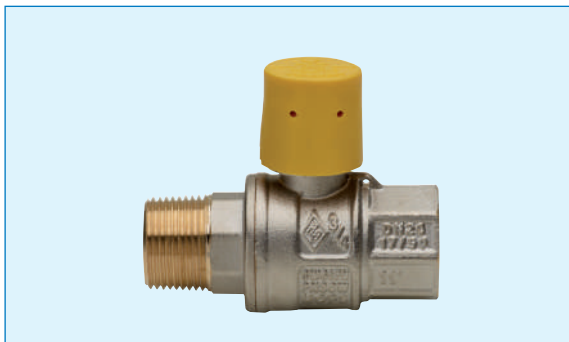

MISURA SIZE	DN	BOX	MASTER BOX	CODICE CODE	ØP	I	L	ØH	Ch	h	MOP	Kg
3/4"	20	25	50	9044050000	20	16,3	69	39	31	55	5	0,34
1"	25	20	40	9044060000	25	19,1	83	49	38	59	5	0,51
1 1/4"	32	10	20	9044070000	32	21,4	96	59	48	69,5	5	0,90
1 1/2"	40	6	12	9044080000	40	21,4	108	73	54	75,5	5	1,37
2"	50	4	8	9044100000	50	25,7	127	87	67	89	5	1,98
2 1/2"	65	2	4	9044120000	65	30,2	152	111	90	108	5	3,67
3"	80	-	4	9044140000	80	33,3	177	136	105	119	5	5,80
4"	100	-	2	9044180000	100	39,3	214	166	130	143	5	10,28

Limiti di temperatura: -20°C +60°C - Temperature range: -20°C +60°C.



Art. 9045

-  Valvola a sfera per colonna montante gas, a passaggio totale, filettatura M/F, con cappuccio piombabile.
-  Full bore ball valve for gas, M/F threaded and sealable cap.
-  Robinet à boisseau sphérique à passage total pour colonne montante gaz, taraudée M/F avec capuchon plombable.
-  Kugelhahn mit vollem Durchgang für Gas, IG/AG und Versiegelungskappe.
-  Válvula esfera paso por columna alimentación gas, paso total, roscas macho/hembra con capucho cerrable.

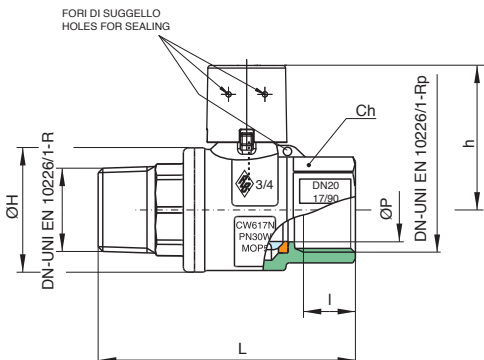



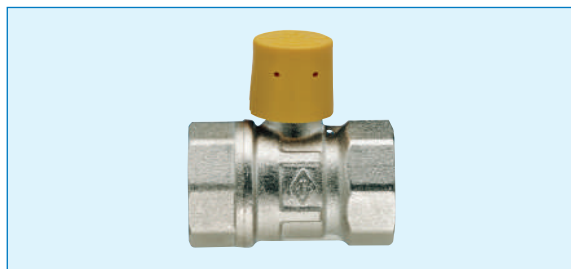

MISURA SIZE	DN	BOX	MASTER BOX	CODICE CODE	ØP	I	L	ØH	Ch	h	MOP	Kg
3/4"	20	25	50	9045050000	20	16,3	81,5	39	31	55	5	0,36
1"	25	20	40	9045060000	25	19,1	94,5	49	38	59	5	0,55
1 1/4"	32	10	20	9045070000	32	21,4	111	59	48	69,5	5	0,98
1 1/2"	40	6	12	9045080000	40	21,4	119	73	54	75,5	5	1,42
2"	50	4	8	9045100000	50	25,7	141,5	87	67	89	5	2,04
2 1/2"	65	2	4	9045120000	65	30,2	175	111	90	108	5	3,98
3"	80	-	4	9045140000	80	33,3	203,5	136	105	119	5	6,18
4"	100	-	2	9045180000	100	39,3	250	166	130	143	5	11,59

Limiti di temperatura: -20°C +60°C - Temperature range: -20°C +60°C.

Art. 9054



-  Valvola a sfera per colonna montante gas, a passaggio ridotto, filettatura F/F, con cappuccio piombabile.
-  Reduced bore ball valve for gas, F/F threaded and sealable cap.
-  Robinet à boisseau sphérique à passage réduit pour colonne montante gaz, taraudée F/F, avec capuchon plombable.
-  Kugelhahn mit reduziertem Durchgang für Gas, beiderseits Innengewinde und Versiegelungskappe.
-  Válvula esfera por columna d'alimentacion gas, paso reducido, rosca hembra/hembra con capucho cerrable.

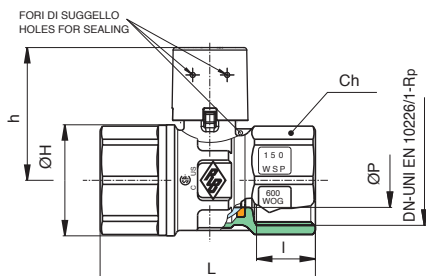

MISURA SIZE	DN	BOX	MASTER BOX	CODICE CODE	ØP	I	ØH	Ch	L	h	MOP	Kg
3/4"	20	25	50	9054050000	15	16,3	34	31	68,5	46	5	0,26
1"	25	25	50	9054060000	20	19,1	41	38	79,5	55	5	0,40
1"1/4	32	12	24	9054070000	25	21,4	52	48	91	59	5	0,67
1"1/2	40	10	20	9054080000	32	21,4	59	54	97	69,5	5	0,88
2"	50	6	12	9054100000	40	25,7	73	67	117,5	75,5	5	1,45
2"1/2	65	4	8	9054120000	50	30,2	93	84	143	90	5	2,83
3"	80	-	4	9054140000	65	33,3	111	100	161	108	5	3,96
4"	100	-	2	9054180000	80	39,3	136	125	193	119	5	6,49

Limiti di temperatura: -20°C +60°C - Temperature range: -20°C +60°C.

serie **INTER-GAS**

Art. **708000**



Valvola a sfera in acciaio, passaggio ridotto, completamente saldata, per gas colonna montante M.P., con estremità a saldare di testa, con leva.



Fully welded steel ball valve, reduced bore, for natural gas transmission and distribution, BW ends, with handle.



Robinet à boisseau sphérique en acier embouti, passage réduit, soudure en bout, pour sectionnement du gaz naturel, avec poignée.



Kugelhahn aus C-Stahl, reduzierter Durchgang, völlig geschweisst, für Gas-Rohrleitung Medium Pressure mit Anschweissenden und Hebel.



Valvula de bola en acero, paso reducido, completamente soldada, para columna de alimentación gas M.P., soldar BW, con palanca.

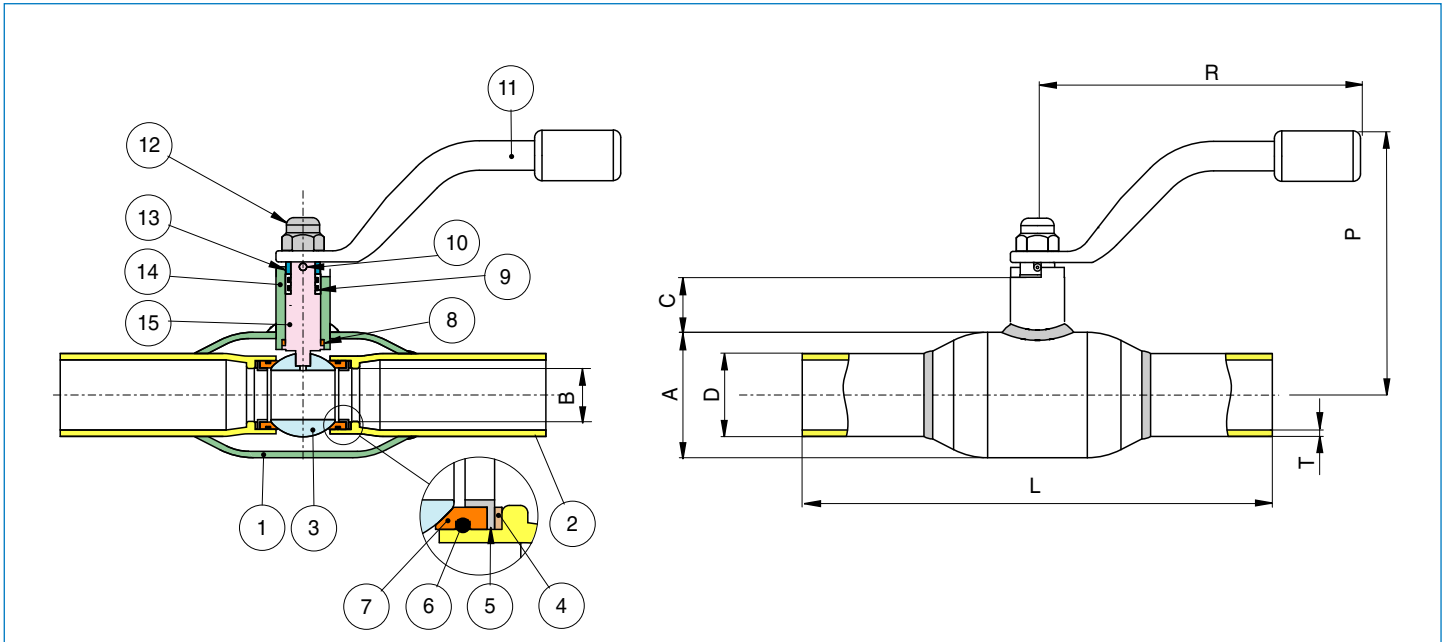





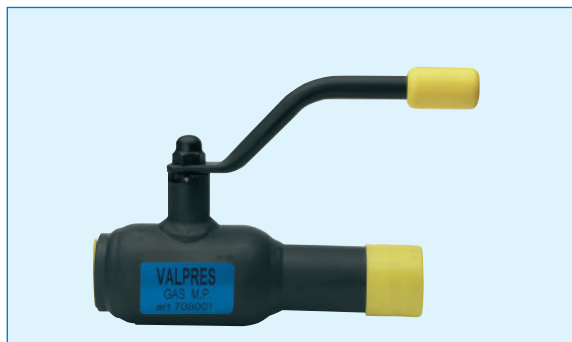

POS.	DENOMINAZIONE	PART NAME	DESCRIPTION	TEILBENENNUNG	DENOMINACION	MATERIALE-MATERIALS MATERIAUX-WERKSTOFF- MATERIAL	N°P
1	CORPO	BODY	CORPS	GEHÄUSE	CUERPO	CARBON STEEL	1
2	MANICOTTO	END CONNECTION	MANCHON	MUFFE	TERMINAL	CARBON STEEL	2
3	SFERA	BALL	BILLE	KUGEL	BOLA	A182-F304	1
4	MOLLA A TAZZA	SPRING WASHER	RESSORT A' DISQUES	TELLERFEDER	MUELLE CONTENEDOR	CARBON STEEL	2
5	RONDELLA	WASHER	RONDELLE	UNTERLEGSCHIEBE	ARANDELA	CARBON STEEL	2
6	O-RING	O-RING	O-RING	O-RING	O-RING	NBR	2
7	GUARNIZIONE SFERA	BALL SEAT	JOINT DE TENUE BILLE	KUGELDICHTUNG	ASIENTO ESFERA	P.T.F.E. + 25% CARBOGRAFITE	2
8	RONDELLA ASTA	THRUST WASHER	RONDELLE DE L'AXE	SPINDELSCHIEBE	EMPAQUETADURA	P.T.F.E. + 25% CARBOGRAFITE	1
9	GUARNIZIONE	SEAT	JOINT	DICHTUNG	JUNTAS	P.T.F.E. + 25% CARBOGRAFITE	1
10	SPINA MEZZOGIRO	90° STOP	90° STOP	90° STOP	90° STOP	STAINLESS STEEL	1
11	LEVA	HANDLE	POIGNÉE	HANDHEBEL	PALANCA	CARBON STEEL	1
12	DADO	NUT	ECROU	MUTTER	TUERCA	CARBON STEEL	1
13	BUSSOLA PREMIGUARNIZIONE	PACKING GLAND	BAGUE DE PRESSE ETOUPE	VORSPANNRING	MANGUITO PRENSAESTOPAS	CARBON STEEL	1
14	O-RING	O-RING	O-RING	O-RING	O-RING	NBR	2
15	ASTA	STEM	TIGE	SPINDEL	EJE	STAINLESS STEEL	1

MISURA SIZE	DN	BOX	MASTER BOX	CODICE CODE	A	B	L	C	D	T	R	P	Kv	PN	Kg
3/4"	20	5	10	70800005	42	15	230	17	26,9	2,3	140	85	6	40	0,80
1"	25	5	10	70800006	51	20	230	17	33,7	2,6	140	89	14	40	1,00
1"1/4	32	5	10	70800007	57	25	260	17	42,4	2,6	140	93	26	40	1,40
1"1/2	40	2	4	70800008	76	32	260	20	48,3	2,6	180	108	43	40	2,10
2"	50	-	4	70800010	89	40	300	20	60,3	2,9	180	114	64	40	3,00
2"1/2	65	-	1	70800012	108	50	360	31	76,1	2,9	275	114	100	25	4,50
3"	80	-	1	70800014	127	65	370	31	88,9	3,2	275	124	160	25	6,00
4"	100	-	1	70800018	152	80	390	78	114,3	3,6	365	192	280	25	9,70

Limiti di temperatura: -20°C +80°C - Temperature range: -20°C +80°C.

Art. 708001



-  Valvola a sfera in acciaio, passaggio ridotto, completamente saldata, per gas colonna montante M.P. con estremità filettata femmina/saldare di testa, con leva.
-  Fully welded steel ball valve, reduced bore, for natural gas transmission and distribution, F/BW ends, with handle.
-  Robinet à boisseau sphérique en acier embouti, passage réduit, F/BW, pour sectionnement du gaz naturel, avec poignée. Kugelhahn aus Stahl, reduzierter Durchgang, völlig.
-  Geschweisst, für Gas-Rohrleitung Medium Pressure, einerseits Innengewinde/andererseits Anschweisende, mit Hebel.
-  Valvula de bola en acero, paso reducido, completamente soldada, para columna de alimentacion gas M.P., roscada hembra/soldar BW, con palanca.

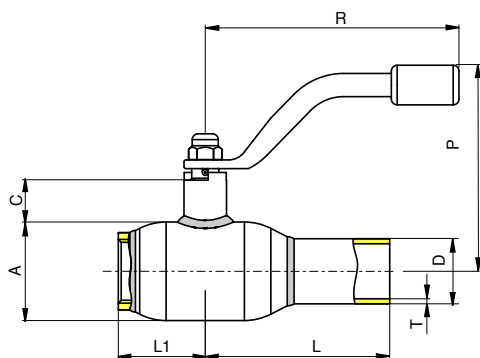

MISURA SIZE	DN	BOX	MASTER BOX	CODICE CODE	A	B	L	L1	C	T	D	R	P	Kv	PN	Kg
3/4"	20	5	10	70800105	42	15	115	38	17	2,3	26,9	140	85	6	40	0,80
1"	25	5	10	70800106	51	20	115	45	17	2,6	33,7	140	89	14	40	0,90
1"1/4	32	5	10	70800107	57	25	130	53	17	2,6	42,4	140	93	26	40	1,30
1"1/2	40	2	4	70800108	76	32	130	60	20	2,6	48,3	180	108	43	40	2,00
2"	50	-	4	70800110	89	40	150	73	20	2,9	60,3	180	114	64	40	2,90





Limiti di temperatura: -20° +80° - Temperature range: -20° +80°

serie **CLICK-SFER**

Art. **9646**

**BREVETTATO
PATENTED**



-  Valvola a sfera per gas a passaggio totale, filettatura F/F, serratura di sicurezza e morosità estraibile e sostituibile.
-  Full bore ball valve for gas, F/F threads with aluminium T-handle and extractable and replaceable security lock.
-  Robinet à boisseau sphérique pour gaz à passage total, taraudée F/F avec poignée à papillon en aluminium, serrure de sécurité, extractible et remplaçable.
-  Gas Kugelhahn, voller Durchgang, Innengewinde mit Aluminium Flügelgriff und mit abschließbarem und austauschbarem Sicherungsschloss.
-  Valvula esfera por gas paso total, rosca hembra/hembra con mariposa de aluminio, cerradura de seguridad y morosidad extractable y sustituible.

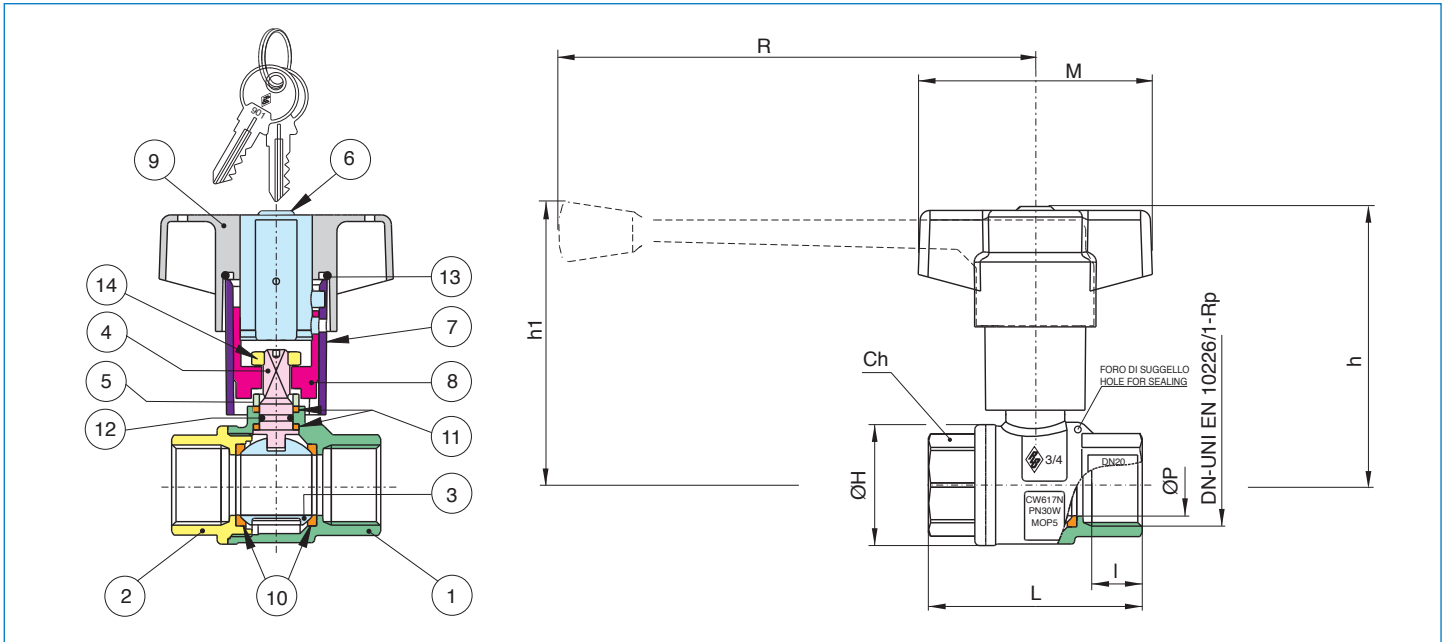

POS.	DENOMINAZIONE	PART NAME	DESCRIPTION	TEILBENENNUNG	DENOMINACION	MATERIALE-MATERIALS MATERIAUX-WERKSTOFF- MATERIAL	N°P
1	CORPO	BODY	CORPS	GEHÄUSE	CUERPO	OTTONE CW617N UNI EN 12165	1
2	MANICOTTO	END CONNECTION	MANCHON	MUFFE	MANGUITO	OTTONE CW617N UNI EN 12165	1
3	SFERA	BALL	BILLE	KUGEL	ESFERA	OTTONE CW617N UNI EN 12165	1
4	ASTA	STEM	TIGE	SPINDEL	EJE	OTTONE CW614N UNI EN 12164	1
5	BUSSOLA PREMIGUARNIZIONE	PACKING GLAND	BAGUE DE PRESSE ETOUPE	VORSPANNRING	ANILLO PRENSAESTOPA	OTTONE CW614N UNI EN 12164	1
6	SERRATURA	LOCK PROTECTION	SERRURE	SCHLOSSABDECKUNG	CERRADURA	PAmx D6	1
7	COPRI SERRATURA	CAP	COUVRE-SERRURE	KAPPE	TAPÒN CERRADURA	ZAMA - Al Zn Mg ALLOY UNI 1774	1
8	COPRI SERRATURA	CAP	COUVRE-SERRURE	KAPPE	TAPÒN CERRADURA	ZAMA - Al Zn Mg ALLOY UNI 1774	1
9	FARFALLA	T-HANDLE	PIOGNÉE A PAPILLON	GRIFF	MARIPOSA	ALLUMINIO EN-AC 46100 EN 1706	1
10	GUARNIZIONE SFERA	BALL SEAT	JOINT DE TENUE BILLE	KUGELDICHTUNG	JUNTA ESFERA	P.T.F.E	2
11	GUARNIZIONE ANTIATTRITO	STEM SEAL/THRUST WASHER	JOINT DE L'AXE/ANTIFRICTION	STOBHEMMENDE DICHTUNG	JUNTA EJE / ANTI-FRICCIÓN	P.T.F.E	2
12	O-RING	O-RING	O-RING	O-RING	O-RING	NBR	1
13	O-RING	O-RING	O-RING	O-RING	O-RING	MVQ	1
14	DADO	DADO	ECROU	MUTTER	TUERCA	ACCIAIO CL 04	1

MISURA SIZE	DN	BOX	MASTER BOX	CODICE CODE	ØP	I	Ch	ØH	L	h	h1	M	R	MOP	Kg
3/4"	20	-	25	9646050925	20	16,3	31	39	69	86	-	70	-	5	0,48
1"	25	-	25	9646060925	25	19,1	38	49	83	90	-	70	-	5	0,66
*1"1/4	32	5	10	9646070925	32	21,4	48	59	96	-	113	-	160	5	1,16
*1"1/2	40	5	10	9646080925	40	21,4	54	73	108	-	119	-	160	5	1,71
*2"	50	-	5	9646100925	50	25,7	67	87	127,5	-	128	-	160	5	2,31

Limiti di temperatura: -20°C +60°C - Temperature range: -20°C +60°C.

* Versione con leva in alluminio - Version with aluminium handle.

Disponibili accessori, artt. 9602-96T0, a pag. 138 - The accessories, item 9602-96T0, are available. See at page 138.

🇮🇹 SOSTITUZIONE DI UNA SERRATURA ESTRAIBILE

La nuova serie di valvole a sfera e mensole con serratura estraibile BREVETTATA da Rubinetterie Bresciane consente **LA SOSTITUZIONE** della serratura in modo semplice e rapido nei casi in cui sia necessario, ad esempio:

- errata collocazione di due valvole con cifrature identiche su due contatori della stessa batteria;
- mancato funzionamento della serratura stessa;
- impossibilità di manovrare la serratura stessa perchè manomessa da atti di vandalismo, oppure abbia una chiave spezzata al suo interno (procedura non indicata, le cui modalità sono fornite alle aziende distributrici su richiesta)

- La sostituzione viene eseguita solamente quando la serratura è in posizione di morosità (non a valvola chiusa), condizione per la quale l'operazione è eseguibile esclusivamente da parte dell'azienda in possesso del passe-partout e della chiave di estrazione.

- L'operazione di sostituzione si esegue a valvola aperta, quindi senza interrompere il gas all'utente evitando così i grandi disagi che ciò comporterebbe.

TRASFORMAZIONE DI UNA VALVOLA STANDARD

La soluzione BREVETTATA da Rubinetterie Bresciane consente **LA TRASFORMAZIONE** da una valvola standard in esercizio, in una valvola con serratura di sicurezza e morosità estraibile.

L'operazione consente di applicare la serratura ad una valvola Rubinetterie Bresciane già in esercizio, in modo semplice, rapido ed economico senza interrompere l'erogazione del gas!

Questo consente di:

- a) Risparmiare tempo e denaro nell'adeguamento degli impianti secondo la norma UNI 9036.
- b) Evitare lo smontaggio del contatore.
- c) Evitare lo smontaggio e rottamazione della valvola con serratura completa.
- d) Evitare l'acquisto di una valvola con serratura completa.
- e) Evitare di avvisare e concordare con l'utente la tempistica di chiusura e riapertura del contatore.

🇬🇧 REPLACEMENT OF A REMOVABLE LOCK

The new set of ball valves and brackets with removable lock PATENTED by Rubinetterie Bresciane, allows the **REPLACEMENT** of the lock easily, quickly, when needed, for instance:

- wrong placement in the set of two valves with the same code/figure on two adjacent gas meters;
- lock out of service of the locking it self;
- impossibility to maneuver the lock due to vandalism acts, or for the presence of a broken key inside;

- The lock is replaced just when it's closed, that's why the replacement can be carried out from the firm owing the master key of the extracting key.

- The replacement is carried out while the valve is opened, avoiding the gas'supply stop.

TRANSFORMATION OF A STANDARD VALVE

The option PATENTED by Rubinetterie Bresciane allows the **TRANSFORMATION** of a standard valve, in a new one with safety locking device and removable lock.

This solution delivers a new valve Rubinetterie Bresciane with security lock without stopping the gas supply!

This allows to:

- a) Save time and money adapting the line according to the UNI 9036 rule.
- b) Avoid dismantling the gas meter.
- c) Avoid dismantling and wrecking the valve with the whole lock.
- d) Avoid buying a valve with an entire lock.
- e) Avoid informing and agreeing with the customer the times for the maintenance of the gas meter.

REPLACEMENT D'UNE SERRURE EXTRACTIBLE

La nouvelle série de vannes à boisseau sphérique avec serrure extractible BREVETTÉ par Rubinetteria Bresciane permet le **REPLACEMENT** du serrure en manière simple et rapide en cas dans il est nécessaire, par exemple:

- placement erroné en batterie de deux vannes avec chiffrage identique sur deux compteurs adjacents;
- manqué fonctionnement du serrure;
- impossibilité à manoeuvrer la serrure, parce que fouillée par actions de vandalisme, ou une clé cassée à l'intérieur (cette procédure n'est pas indiquée, Ses modalités viennent fournies aux sociétés sur demande).

- Le remplacement vient effectué seulement quand la serrure est en position de blocage, condition pour la quelle l'opération est exécutable exclusivement par la société en possession du passe-partout et du clé d'extraction.
- L'opération de remplacement vient effectué à vanne ouverte, par conséquent sans interrompre la distribution du gaz au consommateur, en évitant les grands desagréments que cela implique.

TRANSFORMATION D'UNE VANNE STANDARD

La solution BREVETTÉ par Rubinetteria Bresciane permet la **TRANSFORMATION** d'une vanne standard en exercice, en une vanne avec serrure de sécurité extractible.

L'opération permet d'appliquer la serrure à une vanne Rubinetteria Bresciane déjà en exercice, d'un simple façon, rapide et économique sans interrompre la distribution du gaz!

Cela permet de:

- a) Économiser du temps et d'argent dans l'ajustement des installations selon la norme UNI 9036.
- b) Éviter le démontage du compteur.
- c) Éviter le démontage et le ferraillement du vanne avec serrure complète.
- d) Éviter l'acquisition d'une vanne avec serrure complète.
- e) Éviter d'avertir et arranger avec le consommateur le temps de fermeture et reouverture rouvrir du compteur.

AUSWECHSELUNG EINES ERSETZBAREN SCHLOSSES

Die neuen Kugelhähne und Gaszählerplatten mit ersetzbarem Schloß, patentiert durch Rubinetteria Bresciane, ermöglichen eine einfache und schnelle auswechslung des Schlosses in verschiedene Fällen. Hier einige Beispiele:

- Falsche Anbringung von zwei Kugelhähnen mit ein und desselben Schlosses, bei zwei angrenzenden Gaszählern;
- Defekt eines Schlosses;
- Schloß kann nicht betätigt werden auf Grund von Vandalismus, oder wenn der Schlüssel im Schloß bricht.

- Das Schloß kann in geschlossener Stellung ausgetauscht werden. Der Austausch kann durch die Gasgesellschaft durchgeführt werden, die im Besitz des Generalschlüssels ist.
- Der Austausch kann durchgeführt werden während der Hahn geöffnet ist, um die Gasversorgung nicht zu unterbrechen.

UMBAU EINES STANDARDHAHNS

Die Option, durch Rubinetteria Bresciane patentiert, ermöglicht den **UMBAU EINES** Standardkugelhahns in einen neuen Hahn mit Sicherheitsabsperrvorrichtung und austauschbarem Schloß.

Diese Lösung liefert einen neuen Rubinetteria Bresciane-Kugelhahn mit Sicherheitsabsperrung ohne die Gasversorgung zu unterbrechen!

Dieses ermöglicht folgendes:

- a) Zeit und Geldersparnis während die Rohrleitung gem. UNI9036 umgerüstet wird.
- b) Vermeidung der Demontage des Gaszählers.
- c) Vermeidung der Demontage des Kugelhahnes mit dem kompletten Schloß.
- d) Vermeidung des Zukaufes eine Kugelhahnes mit integriertem Schloß.
- e) Vermeidung von Abstimmung mit den Kunden für die Instandhaltungs- und Umrüstzeiten.

SUBSTITUCIÓN DE UNA CERRADURA EXTRACTABLE

La nueva serie de válvulas y mensuras esfera con cerradura extractable patentadas de Rubinetterie Bresciane permite la **SUBSTITUCIÓN** de la cerradura misma con un sistema simple y rápido, en los casos donde resulte necesario. Por ejemplo:

- colocación equivocada en batería de 2 válvulas con cifras idénticas en 2 medidores adyacentes;
- mancato funcionamiento de la misma cerradura;
- imposibilidad de maniobrar la cerradura porque manipulada por actos vandálicos o presencia de una llave quebrada al interior (procedimiento que no indicamos - las modalidades son entregadas a las empresas de distribución bajo pregunta específica).

- La substitución es efectuada solamente cuando la cerradura es en posición de morosidad, condición por la cual l'operación la puede reseguir solamente l'empresa que posee la llave matriz y la llave d'esracion.
- L'operación de substitución se conduce con la válvula abierta, pues evitando l'interrupcion del suministro del gas al usuario con las dificultades que implicaría.

TRANSFORMACIÓN DE UNA VÁLVULA ESTÁNDAR

La solución patentada de Rubinetterie Bresciane permite la **TRANSFORMACIÓN** de una válvula estándar en ejercicio en una válvula con cerradura de seguridad y morosidad extractable.

¡L'operación permite d'aplicar la cerradura a una válvula de Rubinetterie Bresciane ya en ejercicio con un sistema simple, rápido y económico sin parar el suministro del gas!





Esto significa:

- a) D'ahorrar tiempo y dinero por adaptar las instalaciones en conformidad a la norma UNI 9036.
- b) Evitar de desarmar el medidor.
- c) Evitar de desarmar y tirar la válvula con cerradura completa.
- d) Evitar la compra de una nueva válvula con cerradura completa.
- e) Evitar de concordar con l'usuario fechas y horas cuando el medidor será antes cerrado y luego nuevamente abierto.



Art. 9638

**BREVETTATO
PATENTED**

-  Valvola a sfera per gas a passaggio totale, filettatura maschio con raccordo per contatore gas, serratura di sicurezza e morosità, estraibile e sostituibile.
-  Full bore ball valve for gas, male thread with connection for gas meter, extractable and replaceable security lock.
-  Robinet à boisseau sphérique pour gaz à passage total, taraudée male avec raccord pour compteur à gaz, serrure de sécurité, extractible et remplaçable.
-  Gas Kugelhahn, voller Durchgang, Innengewidw mit Anschluss für gaszähler und mit abschliessbarem und austauschbarem Sicherheitsschloss.
-  Valvula esfera por gas paso total, rosca macho con racor por medidor gas, cerradura de seguridad y morosidad, extractable y sustituible.

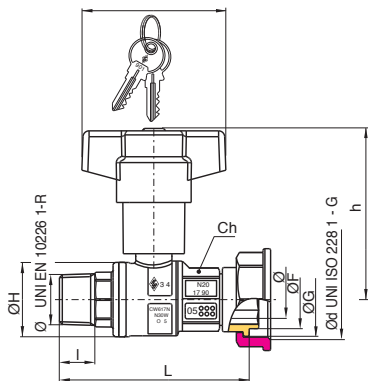





ØD x Ød	BOX	MASTER BOX	CODICE CODE	ØP	I	Ch	ØH	L	h	ØF	ØG	M	MOP	Kg
3/4" x 1"1/4	-	25	9638280925	20	16,3	46	39	99	86	31	39,5	70	5	0,88
1" x 1"1/4	-	25	9638290925	25	19,1	46	49	114	86	31	39,5	70	5	0,69

Limiti di temperatura: -20°C +60°C - Temperature range: -20°C +60°C.



Art. 9639

**BREVETTATO
PATENTED**

-  Valvola a sfera per gas a passaggio totale, filettatura femmina con raccordo per contatore gas, serratura di sicurezza e morosità, estraibile e sostituibile.
-  Full bore ball valve for gas, female thread with connection for gas meter, extractable and replaceable security lock.
-  Robinet à boisseau sphérique pour gaz à passage total, taraudée femelle avec raccord pour compteur à gaz, serrure de sécurité, extractible et remplaçable.
-  Gas Kugelhahn, voller Durchgang, Innengewidw mit Anschluss für gaszähler und mit abschliessbarem und austauschbarem Sicherheitsschloss.
-  Valvula esfera por gas paso total, rosca hembra con racor por medidor gas, cerradura de seguridad y morosidad extractable y sustituible.

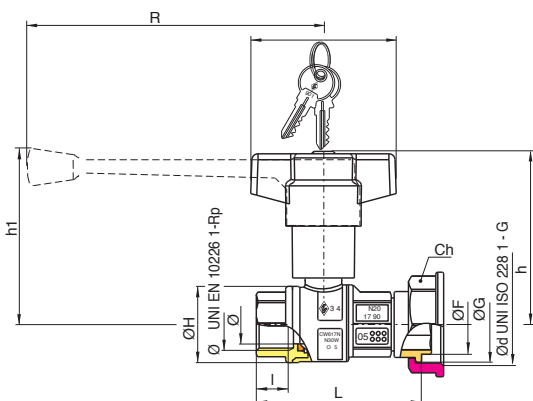

ØD x Ød	BOX	MASTER BOX	CODICE CODE	ØP	I	Ch	ØH	L	h	h1	ØF	ØG	M	R	MOP	Kg
3/4" x 1"1/4	-	25	9639280925	20	16,3	46	39	85,5	86	-	31	39,5	70	-	5	0,66
1" x 1"1/4	-	25	9639290925	25	19,1	46	49	102,5	90	-	31	39,5	70	-	5	0,86
*1"1/2 x 2"	-	5	9639690925	40	21,4	63	73	130	-	119	46	57	-	160	5	2,15
*2" x 2"1/2	-	5	9639700925	50	25,7	80	87	151	-	128	59	72,5	-	160	5	3,02





Limiti di temperatura: -20°C +60°C - Temperature range: -20°C +60°C.

* Versione con leva in alluminio - Version with aluminium handle.

Art. 9647

**BREVETTATO
PATENTED**



-  Valvola a sfera per gas a passaggio totale, filettatura M/F, serratura di sicurezza e morosità estraibile e sostituibile.
-  Full bore ball valve for gas, M/F threads, extractable and replaceable security lock.
-  Robinet à boisseau sphérique pour gaz à passage total, taraudée M/F, serrure de sécurité, extractible et remplaçable.
-  Gas Kugelhahn, voller Durchgang, IG/IG, mit abschliessbarem und austauschbarem Sicherungsschloss.
-  Valvula esfera por gas paso total, roscas macho/hembra, cerradura de seguridad y morosidad extractable y sustituible.

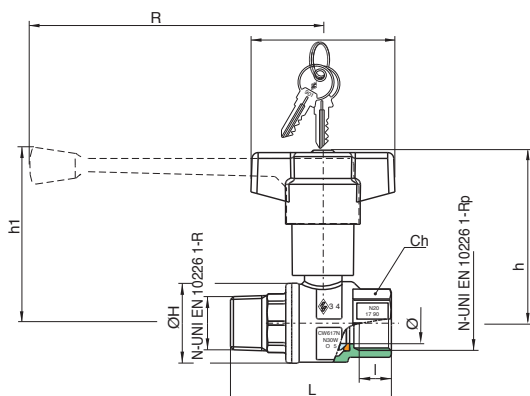

MISURA SIZE	DN	BOX	MASTER BOX	CODICE CODE	ØP	I	L	Ch	ØH	h	h1	R	M	MOP	Kg
3/4"	20	-	25	9647050925	20	16,3	81,5	31	39	86	-	-	70	5	0,51
1"	25	-	25	9647060925	25	19,1	94,5	38	49	90	-	-	70	5	0,70
*1"1/4	32	5	10	9647070925	32	21,4	111	48	59	-	113	160	-	5	1,24
*1"1/2	40	5	10	9647080925	40	21,4	119	54	73	-	119	160	-	5	1,75
*2"	50	-	5	9647100925	50	25,7	141,5	67	87	-	128	160	-	5	2,36





Limiti di temperatura: -20°C +60°C - Temperature range: -20°C +60°C.

* Versione con leva in alluminio - Version with aluminium handle.



Art. 9679

**BREVETTATO
PATENTED**

-  Valvola a sfera per gas a passaggio totale, a squadra, filettatura femmina, con raccordo per contatore gas, serratura di sicurezza e morosità, estraibile e sostituibile.
-  Angle full bore ball valve for gas, female threaded and gas meter connection, and security lock, extractable and replaceable security lock.
-  Robinet à boisseau sphérique pour gaz à passage total, taraudée femelle, à équerre, avec raccord pour compteur à gaz, serrure de sécurité, extractible et remplaçable.
-  Eck-Kugelhahn mit vollem Durchgang für Gas, Innengewinde und Anschluss für Gaszähler mit abschliessbarem, und austauschbarem Sicherungsschloss.
-  Válvula esfera angular por gas a paso total, roscas hembra/hembra, con conexión por medidor, cerradura de seguridad y morosidad, extractable y sustituible.

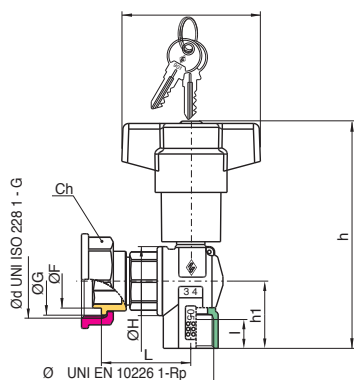





ØD x Ød	BOX	MASTER BOX	CODICE CODE	I	L	Ch	ØH	ØF	ØG	h	h1	M	MOP	Kg
3/4" x 1"1/4	-	25	9679280925	16,3	51	46	39	30,5	38,5	123	38	70	5	0,64
1" x 1"1/4	-	25	9679290925	19,1	63	46	49	30,5	38,5	134	45,5	70	5	0,87

Limiti di temperatura: -20°C +60°C - Temperature range: -20°C +60°C.



Art. 9602 KIT S

ART. PER AZIENDE DI DISTRIBUZIONE GAS (MULTIUTILITY)





-  Kit di sostituzione serratura per valvole serie CLICK-SFER 9638-9639-9647-9679-967C-967T.
-  Kit for lock replacement of the valves Series CLICK-SFER 9638-9639-9647-9679-967C-967T.
-  Jeu de substitution serrure pour vannes de la série CLICK-SFER 9638-9639-9647-9679-967C-967T.
-  Kit für Austausch des Schlosses der Kugelhähne Serie CLICK-SFER 9638-9639-9647-9679-967C-967T.
-  Juego de substitución cerradura por válvulas serie CLICK-SFER 9638-9639-9647-9679-967C-967T.

MISURE	1/2" - 3/4" - 1"
BOX	-
MASTER BOX	25
CODICE - CODE	9602050925



Art. 96TO KIT T

ART. PER AZIENDE DI DISTRIBUZIONE GAS (MULTIUTILITY)





-  Kit per la trasformazione di una valvola standard, nella versione con serratura estraibile serie CLICK SFER .
-  Kit for the conversion of the ball valve into the option with extractable lock Series CLICK SFER.
-  Jeu pour la transformation d'une vanne dans l'option avec serrure extraible série CLICK-SFER.
-  Kit für Umbau des Kugelhahnes in einen Kugelhahn mit austauschbarem Schloss Serie CLICK SFER.
-  Juego por la transformación de una válvula en l'opcion con cerradura extractable serie CLICK SFER.

MISURE	1/2"	3/4" - 1"	1"1/4 - 1"1/2	2"
BOX	-	-	5	5
MASTER BOX	25	25	20	20
CODICE - CODE	96T0040000	96T0050000	96T0070925	96T0100925



Art. 96CO KIT T

ART. PER AZIENDE DI DISTRIBUZIONE GAS (MULTIUTILITY)



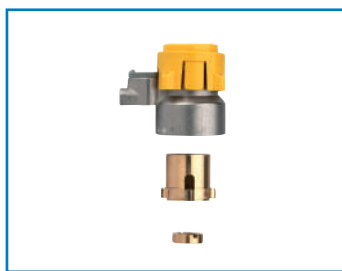

-  Kit per la trasformazione di una valvola standard di altra marca nella versione con serratura estraibile serie CLICK-SFER.
-  Kit for the conversion of a foreign ball valve into the option with extractable lock Series CLICK-SFER.
-  Jeu complet pour la transformation d'une vanne d'autre marque dans l'option avec serrure extraible série CLICK-SFER.
-  Kit für Umbau eines Kugelhahnes (Fremdfabrikat) in einen Kugelhahn mit austauschbarem Schloss Serie CLICK-SFER.
-  Juego completo por la transformación de una válvula de otra marca en l'opcion con cerradura extractable serie CLICK SFER.

MISURE	1/2" - 3/4" - 1"
BOX	25
MASTER BOX	50
CODICE - CODE	96C1050000



Art. 97K0





ART. PER AZIENDE DI DISTRIBUZIONE GAS (MULTIUTILITY)

-  Kit per la trasformazione di una valvola standard nella versione con blocco di sicurezza e cappuccio di protezione.
-  Kit for the conversion of the ball valve into an option with safety lock and protection cap.
-  Jeu pour la transformation d'une vanne en l'option avec stop de sécurité couvercle de protection.
-  Kit für Umrüstung des Kugelhahnes in einen Kugelhahn mit Sicherheitsschloss und Schutzkappe.
-  Juego por la transformación de una válvula en l'opcion con bloqueo de seguridad y capucho de protección.

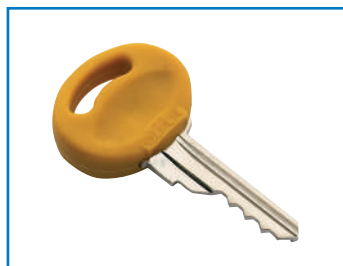
MISURE	3/4"	1"	1"1/4	1"1/2	2"
BOX	25	25	20	15	15
MASTER BOX	50	50	40	30	30
CODICE - CODE	97K0060000	97K0060000	97K0070000	97K0070000	97K0100000

ART. PER AZIENDE DI DISTRIBUZIONE GAS (MULTIUTILITY)







Art. PASSE-PARTOUT

-  Passe-partout per valvole con serrature in ottone/tecnopolimero.
-  Master key for brass and polymer lock valves.
-  Passepartout pour vannes avec serrure en laiton/polymère.
-  Generalschlüssel für Kugelhähne mit Messing/Polymer Sicherheitsschloss.
-  Llave universal por válvulas con cerradura en latón/polimero.

MISURE	-	-
Q.TA'	1 PEZZO	1 PEZZO
CODICE - CODE	5809000025	5809000G00

ART. PER AZIENDE DI DISTRIBUZIONE GAS (MULTIUTILITY)







Art. 5809000004 CHIAVE ESTRATTORE

-  Estrattore per valvole con serrature estraibili e blocco di sicurezza.
-  Key for the extraction of the lock.
-  Extracteur pour vannes avec serrures extractible et bloc de sécurité.
-  Schlüssel für die Demontage des Schlosses.
-  Extractor por válvulas con cerradura extractable y bloqueo de seguridad.

MISURE	-	-
Q.TA'	1 PEZZO	-
CODICE - CODE	5809000004	-

ART. PER AZIENDE DI DISTRIBUZIONE GAS (MULTIUTILITY)





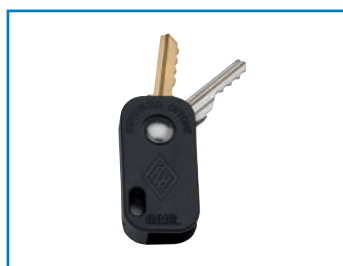

Art. 5809000005

-  Chiave di sblocco per valvole con serratura serie FIDO-SFER artt. 9700-9701.
-  Unlocking key for lockable valves Series FIDO-SFER artt. 9700-9701.
-  Clef de déblocage pour vannes avec fermeture série FIDO-SFER réf. 9700-9701.
-  Schlüssel für Ventile mit Schloss der Serie FIDO-SFER artt. 9700-9701.
-  Llave de desbloqueo para válvulas con cerradura serie FIDO-SFER art. 9700-9701.

MISURE	-	-
Q.TA'	1 PEZZO	-
CODICE - CODE	5809000005	-

ART. PER AZIENDE DI DISTRIBUZIONE GAS (MULTIUTILITY)

Art. 5809000GPO PASSE PARTOUT DOPPIO

-  Passe-partout doppio per valvole con serrature in ottone e in tecnopolimero.
-  Double master key for valves with brass and polymer lock.
-  Passe-partout double pour vannes avec serrures en laiton et en polymère.
-  Doppel-Generalschlüssel für Kugelhähne mit Messing und Polymer Sicherheitsschloss.
-  Llave universal doble por válvulas con cerradura en latón y en polimero.

MISURE	-	-
Q.TA'	1 PEZZO	-
CODICE - CODE	5809000GPO	-

NUOVI CODICI MENSOLE: UN AIUTO PER I TUOI ACQUISTI

Una nuova struttura di codifica è stata creata per poter facilitare la scelta e l'acquisto delle mensole di Rubinetterie Bresciane; che nell'ambito delle numerose soluzioni proposte permette di poter ordinare:

1. Solo la VALVOLA per mensola gas nelle diverse soluzioni.
2. Solo i FERRI per mensola gas nelle diverse soluzioni.
3. La VALVOLA+FERRI per mensola gas tradizionale.

La tabella di seguito riporta i codici delle valvole (1° colonna), le misure disponibili (2° colonna), un esempio dei ferri abbinabili alle valvole stesse (3° colonna) e il codice dell'insieme completo valvola + ferri tradizionali (4° colonna).

Nelle pagine successive del listino troverete moltissime altre soluzioni di ferri mensola che possono essere comunque abbinati alle valvole indicate in tabella e a pagina 142-143.

NEW BRACKET CODES: HELP FOR YOUR PURCHASES

A new codification structure has been done in order to facilitate the choice and the purchase of the gas brackets of Rubinetterie Bresciane that, among the different solutions offered, allows to order:

1. The valve only, available in different options, of the gas bracket.
2. The iron components only, available in different options, of the gas bracket.
3. The valve and the iron components for the traditional gas bracket.

The nearby table shows the codes of the valves (column 1), the available sizes (column 2), one example of iron components of the brackets suitable for the valves (column 3) and the code of the entire gas bracket made by valve and iron components (column 4).

In the next pages of the price list, you'll find many other solutions of iron components for gas brackets which are also suitable with the valves listed in the table at page 142-143.

LES NOUVEAUX CODES DES CONSOLES: UNE AIDE POUR VOS ACQUISITIONS:

Une nouvelle structure de codification a été créée pour vous faciliter le choix et l'acquisition des consoles de Rubinetterie Bresciane, que dans les nombreuses solutions proposées permet de pouvoir commander:

1. La seule vanne à boisseau sphérique pour console gaz dans les différentes solutions.
2. Les fers pour console gaz dans les solutions différentes.
3. La vanne + les fers pour console gaz traditionnelle.

Le tableau à côté indique les codes des vannes (1ère colonne), les dimensions disponibles (2ème colonne), un exemple d'accouplement des fers avec les vannes (3ème colonne) et le code d'ensemble complète de vanne + fers traditionnel (4ème colonne).

Dans les pages suivantes du liste des prix vous trouverez beaucoup d'autres solutions des fers console qui peuvent être combinés aux vannes indiquées dans le tableau et à page 142-143.

NEUE CODE DER TRAGWINKEL: EINE HILFE FÜR IHRE KÄUFE.

“Eine neue Kodifizierungssystematik wurde aufgestellt, um die Auswahl und den Einkauf der Gaszählerplatten von Rubinetterie Bresciane, unter Berücksichtigung der verschiedenen Möglichkeiten, zu vereinfachen:

1. Kugelhahn separat, verfügbar für unterschiedliche Gaszählerplatten.
2. Halterungselemente separat, verfügbar für verschiedene Gaszählerplatten.
3. Kugelhahn und Halterungselemente für die herkömmlichen Gaszählerplatten.

Die nebenstehende Tabelle zeigt die Codes der Hähne (Spalte 1), die verfügbaren Größen (Spalte 2), eine Möglichkeit der Halterungselemente passend zu den Kugelhähnen (Spalte 3) und die Codes der Gaszählerplatten, bestehend aus Halterungselement und Kugelhahn.

In den folgenden Seiten der Preisliste finden Sie eine große Anzahl anderer Lösungen von Halterungselementen für Gaszählerplatten, die auch zu den Hähnen der Tabelle passen 142-143.

NUEVOS CÓDIGOS MÉNSULAS; UNA AYUDA POR TUS PEDIDOS

Para facilitar la selección y compra de las mensulas de Rubinetterie Bresciane ha sido creado un nuevo sistema de codificación que permite pedir:











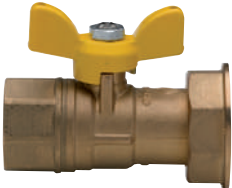

1. Solamente la válvula, por las varias mensulas gas.
2. Solamente los hierros por las varias mensulas gas.
3. Las válvulas mas hierros por mensulas gas tradicionales.

Las tablas a lado reportan los códigos de las válvulas (1° columna), las medidas disponibles (2° columna), un ejemplo de los hierros asociables a las mismas válvulas (3° columna) y el código del paquete completo válvula más hierros tradicionales (4° columna).

En las páginas sucesivas de la lista de precios encontrarán muchas otras soluciones de hierros mensulas que pueden, de cualquier modo, ser asociadas a las válvulas indicada tabla y a página 142-143.

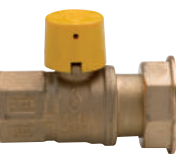





CODICE VALVOLA VALVE CODE	MISURA VALVOLA VALVE SIZE	CODICE COMPONENTE COMPONENT VALVE	CODICE VALVOLA + COMPONENTE VALVE CODE + COMPONENT
 946C	1/2" x 3/4" 1/2" x 1"1/4 1" x 1"1/4	 9F00	9468
		 9F02	6183
		 9F22	6196
 967C SERRATURA TECNOPOLIMERO TECNOPOLYMER LOCK	1/2" x 3/4" 1/2" x 1"1/4 3/4" x 1"1/4 1" x 1"1/4	 9F00	6302
		 9F04	9674
		 9F05	9675
 967T VALVOLA DI ATTIVAZIONE D'UTENZA ACCOUNT ACTIVATION VALVE	3/4" x 1"1/4 1" x 1"1/4	 9F050	6358
		 9F66	6324

CODICE VALVOLA VALVE CODE	MISURA VALVOLA VALVE SIZE	CODICE VALVOLA + COMPONENTE VALVE CODE + COMPONENT
 <p>946E</p>	<p>3/4" x 1"1/4 1" x 1"1/4</p>	 9F00
		 9F02
		 9F05
		 9F22
 <p>947E SERRATURA FISSA FIXED LOCK</p>	<p>3/4" x 1"1/4 1" x 1"1/4</p>	 9F00
		 9F02
		 9F05
		 9F22
 <p>948E CAPPUCCIO PIOMBABILE SEALABLE CAP</p>	<p>1" x 1"1/4</p>	 9F00
		 9F04
		 9F05
 <p>978E BLOCCO DI SICUREZZA SECURITY LOCK</p>	<p>1" x 1"1/4</p>	 9F50
		 9F66

serie FIDO-SFER

Art. 946 C



-  Valvola a sfera per contatore gas, con attacco per ferro mensola.
-  Ball valve for gas meter with connection for meter bracket.
-  Robinet à boisseau sphérique pour compteur à gaz, avec connexion pour console en fer.
-  Gas Kugelhahn für Gaszähler mit Anschluss für Gaszählerplatte.
-  Válvula esfera por medidor gas con conexión por hierro ménsula.

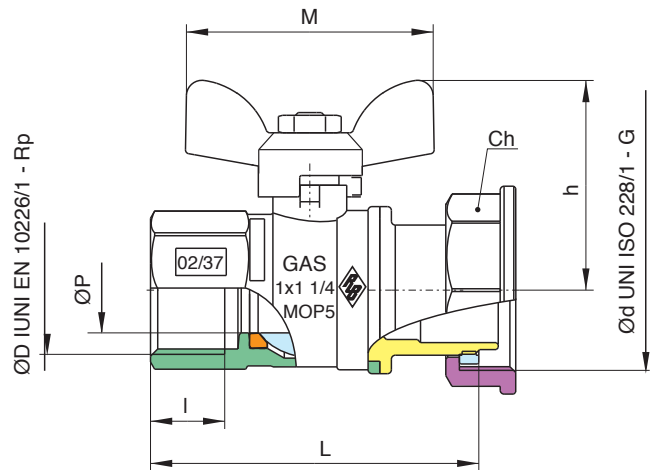
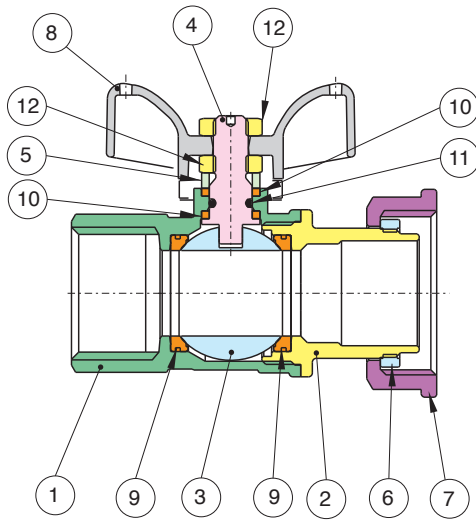

POS.	DENOMINAZIONE	PART NAME	DESCRIPTION	TEILBENENNUNG	DENOMINACION	MATERIALE-MATERIALS MATERIAUX-WERKSTOFF- MATERIAL	N°P
1	CORPO	BODY	CORPS	GEHÄUSE	CUERPO	OTTONE CW617N UNI EN 12165	1
2	MANICOTTO	END CONNECTION	MANCHON	MUFFE	MANGUITO	OTTONE CW617N UNI EN 12165	1
3	SFERA	BALL	BILLE	KUGEL	ESFERA	OTTONE CW617N UNI EN 12165	1
4	ASTA	STEM	TIGE	SPINDEL	EJE	OTTONE CW614N UNI EN 12164	1
5	BUSSOLA PREMIGUARNIZIONE	PACKING GLAND	BAGUE DE PRESSE ETOUPE	VORSPANNRING	ANILLO PRENSAESTOPA	OTTONE CW614N UNI EN 12164	1
6	GHIERA	RING NUT	RACCORD	VORSPANNRING	ANILLO ROSCADO	OTTONE CW614N UNI EN 12164	1
7	GIRELLO	NUT	ECROU	VERSCHRAUBRING	TUERCA LOCA	OTTONE CW617N UNI EN 12165	1
8	FARFALLA	T-HANDLE	POIGNÉE A PAPILLON	GRIFF	MARIPOSA	ALLUMINIO EN AC 46100 EN 1706	1
9	GUARNIZIONE SFERA	BALL SEAT	JOINT DE TENUE BILLE	KUGELDICHTUNG	JUNTA ESFERA	P.T.F.E	1
10	GUARNIZIONE ANTIATTRITO	STEM SEAL/THRUST WASHER	JOINT L'AXE/ANTIFRICTION	STOBHEMMENDE DICHTUNG	JUNTA EJE/ANTIFRICCIÓN	P.T.F.E	1
11	O-RING	O-RING	O-RING	O-RING	O-RING	NBR	1
12	DADO	NUT	ECROU	MUTTER	TUERCA	ACCIAIO 6/s	1





ØD x Ød	BOX	MASTER BOX	CODICE CODE	ØP	I	Ch	L	h	M	MOP	Kg
1/2" x 3/4"	25	50	946C260000	12	15	30	68	40,5	50	5	0,25
1/2" x 1"1/4"	-	25	946C790000	12	15	46	68	40,5	50	5	0,33
1" x 1"1/4"	-	25	946E291000	22	19,1	46	82,5	52,5	64	5	0,53

Limiti di temperatura: -20°C +60°C - Temperature range: -20°C +60°C.

Disponibili accessori, artt. 9602-96T0, a pag. 138 - The accessories, item 9602-96T0, are available. See at page 138.

Art. 967 C CLICK-SFER

**BREVETTATO
PATENTED**

-  Valvola a sfera per contatore gas, con attacco per ferro mensola, con serratura di sicurezza e morosità, estraibile e sostituibile.
-  Ball valve with security lock for gas meter with connection for meter bracket.
-  Robinet à boisseau sphérique pour compteur à gaz, avec connexion pour console en fer, avec serrure de sécurité, extractible et remplaçable.
-  Gas Kugelhahn mit abschliessbarem Flügelgriff für Gaszähler mit Anschluss für Gaszählerplatte.
-  Válvula esfera por medidor gas con conexión por soporte hierro, con cerradura de seguridad y morosidad extractable y sustituible.

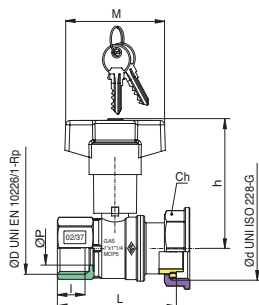
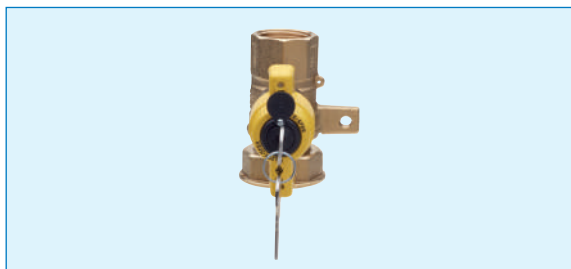





ØD x Ød	BOX	MASTER BOX	CODICE CODE	ØP	I	Ch	L	h	M	MOP	Kg
1/2" x 3/4"	25	50	967C260925	12	15	30	68	40,5	70	5	0,43
1/2" x 1"1/4	-	25	967C790925	12	15	46	68	40,5	70	5	0,52
3/4" x 1"1/4	-	25	967E280925	16	16,3	46	75	82,5	70	5	0,75
1" x 1"1/4	-	25	967E291925	22	19,1	46	82,5	83,5	70	5	0,70

Limiti di temperatura: -20°C +60°C - Temperature range: -20°C +60°C.

Art. 967 T

**BREVETTATO
PATENTED**

-  Valvola a sfera per contatore gas, con attacco per ferro mensola, predisposta al montaggio della serratura estraibile (KIT S), con cappuccio giallo plombabile.
-  Ball valve for gas meter, with connection for meter bracket suitable to be equipped with extractable lock (KIT S) and sealable cap.
-  Robinet à boisseau sphérique pour compteur à gaz, avec connexion pour console en fer, prédisposé au montage de la serrure extractible (KIT S), avec capuchon jaune plombable.
-  Kugelhahn für Gaszähler mit Anschluss für Anbindungsplatte geeignet für den Einbau des austauschbaren Schlosses (KIT S) mit Versiegelungskappe.
-  Válvula esfera por medidor gas con conexión por soporte hierro, ya lista por el armado de cerradura extractable (KIT S), con capucho cerrable amarillo.

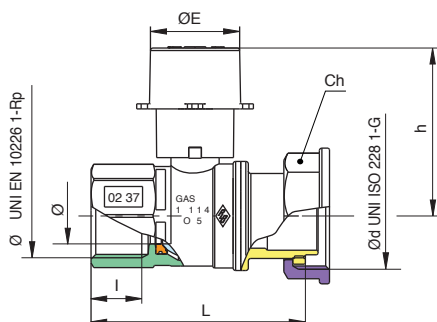





ØD x Ød	BOX	MASTER BOX	CODICE CODE	ØP	I	Ch	L	h	ØE	MOP	Kg
3/4" x 1"1/4	-	25	967T280000	16	16,3	46	75	40	35	5	0,54
1" x 1"1/4	-	25	967T291000	22	19,1	46	82,5	66,5	35	5	0,61

Limiti di temperatura: -20°C +60°C - Temperature range: -20°C +60°C.

Art. 946 E

**BREVETTATO
PATENTED**

-  Valvola a sfera per contatore gas, con attacco per ferro mensola.
-  Ball valve for gas meter with connection for meter bracket.
-  Robinet à boisseau sphérique pour compteur à gaz, avec connexion pour console en fer.
-  Kugelhahn für Gaszähler, mit Anschluss für Anbindungsplatte.
-  Válvula esfera por medidor gas con conexión por soporte hierro.

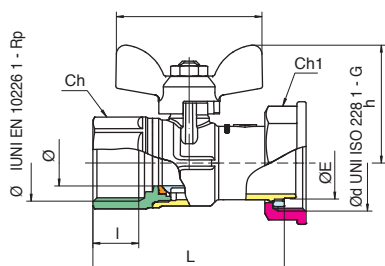





ØD x Ød	BOX	MASTER BOX	CODICE CODE	ØP	I	ØE	Ch	Ch1	L	h	M	MOP	Kg
3/4" x 1"1/4	-	25	946E280000	16	16,3	30,5	31	46	76,5	49	37	5	0,40
1" x 1"1/4	-	25	946E290000	20	19,1	30,5	38	46	83,5	51	37	5	0,48

Limiti di temperatura: -20°C +60°C - Temperature range: -20°C +60°C.

Art. 947 E



-  Valvola a sfera per contatore gas, con attacco per ferro mensola, con serratura di sicurezza e morosità da 3/4" x 1"1/4 a 1" x 1"1/4.
-  Ball valve with security lock for gas meter with connection for meter bracket from 3/4" x 1"1/4 to 1" x 1"1/4.
-  Robinet à boisseau sphérique de 3/4" x 1"1/4 à 1" x 1"1/4 pour compteur à gaz, avec serrure de sécurité et connexion pour console en fer.
-  Kugelhahn für Gaszähler, von 3/4" x 1"1/4" bis zu 1" x 1"1/4, mit Anschluss für Anbindungsplatte und Sicherheitschloss.
-  Válvula esfera de 3/4" x 1"1/4" a 1" x 1"1/4 por medidor gas con conexión por soporte hierro y cerradura de seguridad.

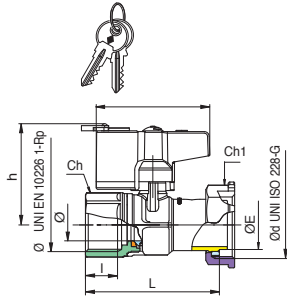



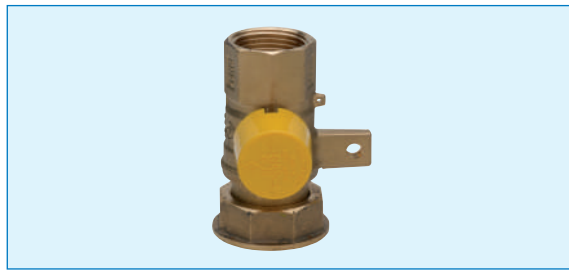

ØD x Ød	BOX	MASTER BOX	CODICE CODE	ØP	I	Ch	Ch1	L	h	ØE	M	MOP	Kg
3/4" x 1"1/4	-	25	947E280025	16	16,3	31	46	76,5	61	30,5	71	5	0,48
1" x 1"1/4	-	25	947E290025	20	19,1	38	46	83,5	63	30,5	71	5	0,56
1" x 1"1/4	-	25	947E291925	22	19,1	38	46	82,5	64,5	30,7	71	5	0,60

Limiti di temperatura: -20°C +60°C - Temperature range: -20°C +60°C.



Art. 948 E

-  Valvola a sfera per contatore gas, con attacco per ferro mensola, con cappuccio giallo piombabile.
-  Ball valve for gas meter, with connection for meter bracket, and sealable cap.
-  Robinet à boisseau sphérique pour compteur à gaz, avec connexion pour console en fer, avec capuchon jaune plombable.
-  Kugelhahn für Gaszähler mit Anschluss für Anbindungsplatte geeignet für den Einbau, mit Versiegelungskappe.
-  Válvula esfera por medidor gas con conexión por soporte hierro, con capucho cerrable amarillo.

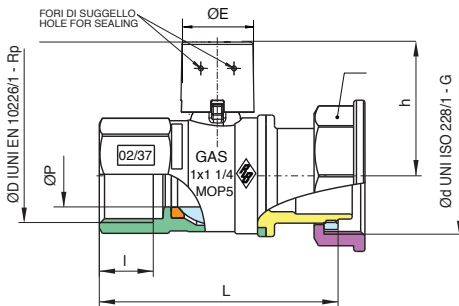



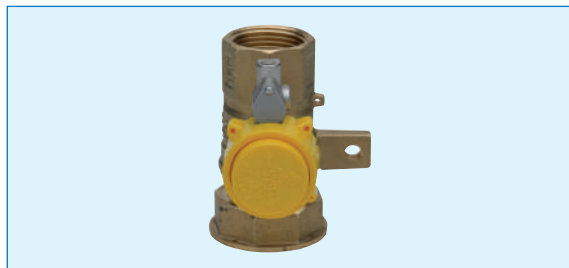

ØD x Ød	BOX	MASTER BOX	CODICE CODE	ØP	I	Ch	L	h	ØE	MOP	Kg
1" X 1"1/4	-	25	948E291000	22	19,1	46	82,5	54,5	32,5	5	0,55

Limiti di temperatura: -20°C +60°C - Temperature range: -20°C +60°C.



Art. 978 E

-  Valvola a sfera per contatore gas, con attacco per ferro mensola, blocco di sicurezza e cappuccio di protezione.
-  Ball valve for gas meter, with connection for meter with security lock and protection cap.
-  Robinet à boisseau sphérique de pour compteur gaz, avec connexion pour console en fer, arrêt et capuchon de sécurité.
-  Kugelhahn für Gaszähler, mit Anschluss für Anbindungsplatte, Sicherheitsanschlag und Versiegelungskappe.
-  Válvula esfera de por medidor gas con conexión por soporte hierro y bloque de seguridad y capucho cerrable.

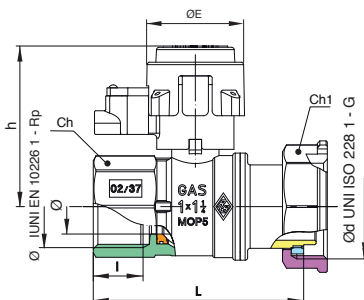

ØD x Ød	BOX	MASTER BOX	CODICE CODE	ØP	ØE	I	Ch	Ch1	L	h	MOP	Kg
3/4" x 1"1/4	-	25	978E280000	16	39	16,3	31	46	75	61,5	5	0,60
1" X 1"1/4	-	25	978E290000	20	39	20	38	46	84,5	63,5	5	0,60
1" X 1"1/4	-	25	978E291000	22	39	19,1	38	46	82,5	67,5	5	0,68

Limiti di temperatura: -20°C +60°C - Temperature range: -20°C +60°C.

POS.	DENOMINAZIONE	PART NAME	DESCRIPTION	TEILBENENNUNG	DENOMINACION	MATERIALE-MATERIALS MATERIAUX-WERKSTOFF- MATERIAL	TRATTAMENTO - TREATMENT	N°P
1	CANNOTTO	UNION TAIL	RACCORD	GEWINDEANSCHLUSS	RACCORD UNION	ACCIAIO S235JR UNI EN 10025	ZINCOTROPICALIZZAZIONE GIALLA	1
2	GIRELLO	NUT	ECROU	VERSCHRAUBRING	TUERCA LOCA	OTTONE CW 617 UNI EN 12165	ZINCOTROPICALIZZAZIONE GIALLA	1
3	TRAVERSA	BEAM	TRAVERSE	BALKEN	TRAVERSA	ACCIAIO S235JR UNI EN 10025	ZINCOTROPICALIZZAZIONE GIALLA	1
4	ZANCA	SUPPORT	SUPPORT	LAGER	SOPORTE	ACCIAIO S235JR UNI EN 10025	ZINCOTROPICALIZZAZIONE GIALLA	1
5	PIASTRA	PLATE	PLAQUE	PLATTE	PLATE	ACCIAIO UNI 7070	ZINCOTROPICALIZZAZIONE GIALLA	1
6	DADO	NUT	ECROU	MUTTER	TUERCA	ACCIAIO	ZINCATURA	1
7	VITE	SCREW	VIS	SCHRAUBE	TORNILLO	ACCIAIO	ZINCATURA	2



Art. 9F00

- Traversa in acciaio, interasse 110 mm con canotto, filettatura ISO 7/1, senza zanca.
- Steel cross beam, center distance 110 mm, with threaded union tail ISO 7/1, without fixing plate.
- Traverse en acier, entre-axes 110 mm, avec raccord, taraudée ISO 7/1, sans support.
- Stahlbalken, Achsenabstand 110 mm, mit Gewindeanschluss ISO 7/1, ohne Anbauplatte.
- Traversa en acero con distancia de 110 mm, con anillo roscado/rosca ISO 7/1 sin soporte.

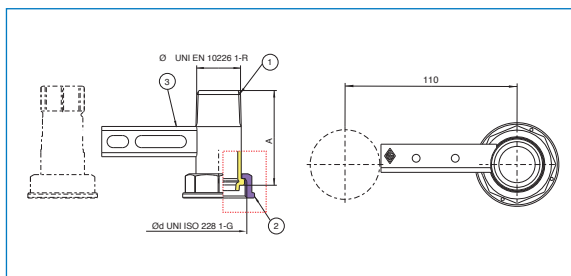

ØD x Ød	BOX	MASTER BOX	CODICE CODE	A
1/2" x 3/4"	-	25	9F00260000	63
1/2" x 1"1/4"	-	25	9F00790000	74
1" X 1"1/4"	-	25	9F00290000	70,5



Art. 9F01

- Traversa in acciaio, interasse 110 mm con canotto, filettatura ISO 7/1, zanca triangolare per tasselli ad espansione.
- Steel cross beam, center distance 110 mm, with threaded union tail ISO 7/1 and fixing plate for raw plugs.
- Traverse en acier, entre-axes 110 mm, avec raccord, taraudée ISO 7/1, avec support triangulaire pour vis murale.
- Stahlbalken, Achsenabstand 110 mm, mit Gewindeanschluss ISO 7/1, mit dreieckiger Anbauplatte für Dübel.
- Traversa en hierro, distancia 110 mm con anillo roscado/rosca ISO 7/1 y soporte triangular por juegos d'expansion.

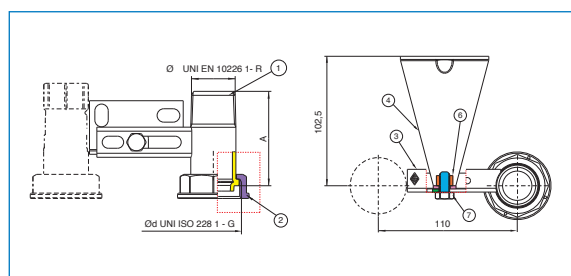





ØD x Ød	BOX	MASTER BOX	CODICE CODE	A
1/2" x 3/4"	-	25	9F01260000	63
1/2" x 1"1/4"	-	25	9F01790000	74
3/4" x 1"1/4"	-	25	9F01280000	72
1" X 1"1/4"	-	25	9F01290000	70,5

ACCOPIABILI CON LE VALVOLE DI PAGG.142-143 - TO BE USED ALONG WITH THE VALVES AT PAGES 142-143

Art. 9F02





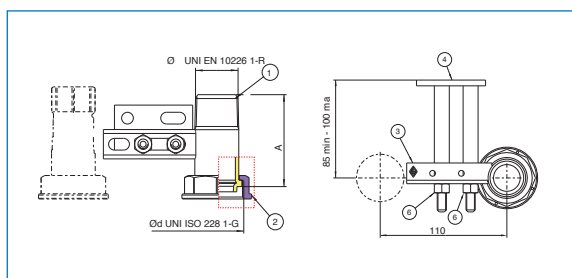

-  Traversa in acciaio, interasse 110 mm con canotto, filettatura ISO 7/1, con zanca a due colonne per tasselli ad espansione.
-  Steel cross beam, center distance 110 mm, with threaded union tail ISO 7/1, with dualcolumn fixing plate.
-  Traverses en acier, entre-axes 110 mm, avec raccord, taraudée ISO 7/1, avec double support pour vis murale.
-  Stahlbalken, Achsenabstand 110 mm, mit Gewindeanschluss ISO 7/1, mit Anbauplatte.
-  Traversa en hierro, distancia 110 mm con anillo roscado/rosca ISO 7/1 y soporte a dos columnas por juegos d'expansion

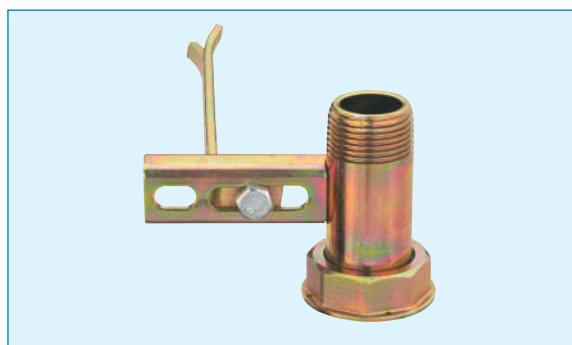

ØD x Ød	BOX	MASTER BOX	CODICE CODE	A
1" X 1"1/4	-	25	9F02290000	70,5



Art. 9F04

-  Traversa in acciaio, interasse 110 mm con canotto, filettatura ISO 7/1, con zanca a murare.
-  Steel cross beam, center distance 110 mm, with thread ISO 7/1, with wall up fixing plate.
-  Traverses en acier, entre-axes 110 mm, avec raccord, taraudée ISO 7/1, avec support mural.
-  Stahlbalken, Achsenabstand 110 mm, mit Gewindeanschluss ISO 7/1, mit Anbauplatte zum einmauern.
-  Traversa en acero con distancia de 110 mm, con anillo roscado/rosca ISO 7/1 sin soporte a murar.

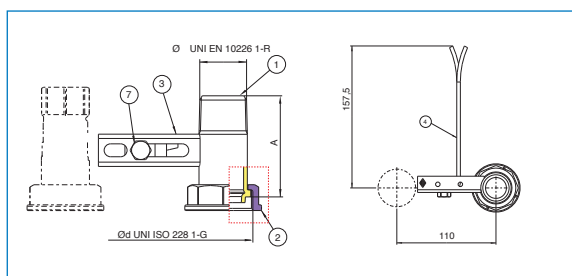



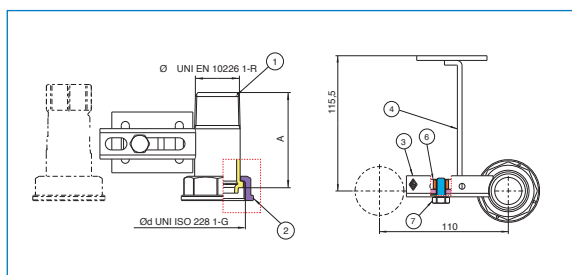

ØD x Ød	BOX	MASTER BOX	CODICE CODE	A
1" X 1"1/4	-	25	9F04290000	70,5

ACCOPIABILI CON LE VALVOLE DI PAGG.142-143 - TO BE USED ALONG WITH THE VALVES AT PAGES 142-143





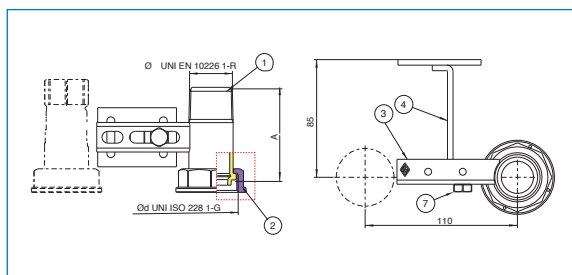

Art. 9F05

-  Traversa in acciaio, interasse 110 mm con canotto, filettatura ISO 7/1 e zanca h.115 per tasselli ad espansione.
-  Steel cross beam, center distance 110 mm, with threaded union tail ISO 7/1 and fixing plate h.115 for raw plugs.
-  Traverse en acier, entre-axes 110 mm, avec raccord, taraudée ISO 7/1, avec support pour vis murale h.115.
-  Stahlbalken, Achsenabstand 110 mm, mit Gewindeanschluss ISO 7/1 und Anbauplatte für Dübel h.115.
-  Traversa en hierro, distancia 110 mm con anillo roscado/rosca ISO 7/1 y soporte h.115 por juegos d'expansion.

ØD x Ød	BOX	MASTER BOX	CODICE CODE	A
1/2" x 3/4"	-	25	9F05260000	63
1/2" x 1"1/4	-	25	9F05790000	74
1" X 1"1/4	-	25	9F05290000	70,5



Art. 9F06





-  Traversa in acciaio, interasse 110 mm con canotto, filettatura ISO 7/1 e zanca h.85 per tasselli ad espansione.
-  Steel cross beam, center distance 110 mm, with threaded union tail ISO 7/1 and fixing plate h.85 raw plugs.
-  Traverse en acier, entre-axes 110 mm, avec raccord, taraudée ISO 7/1, avec support pour vis murale h.85.
-  Stahlbalken, Achsenabstand 110 mm, mit Gewindeanschluss ISO 7/1 und Anbauplatte für Dübel h.85.
-  Traversa en hierro, distancia 110 mm con anillo roscado/rosca ISO 7/1 y soporte h.85 por juegos d'expansion.

ØD x Ød	BOX	MASTER BOX	CODICE CODE	A
1" X 1"1/4	-	25	9F06290000	70,5

ACCOPIABILI CON LE VALVOLE DI PAGG.142-143 - TO BE USED ALONG WITH THE VALVES AT PAGES 142-143



Art. 9F66



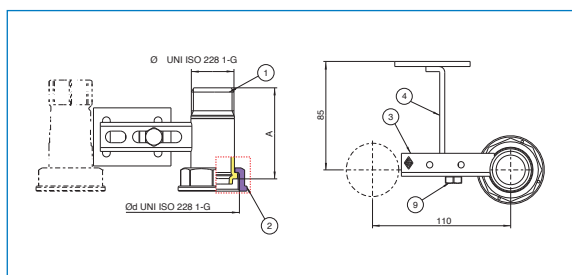

-  Traversa in acciaio, interasse 110 mm con cannotto, filettatura UNI ISO 228 e zanca h.85 per tasselli ad espansione.
-  Steel cross beam, center distance 110 mm, with threaded union tail UNI ISO 228 and plate h.85 for raw plugs.
-  Traverses en acier, entre-axes 110 mm, avec raccord, taraudée UNI ISO 228, avec support pour vis murale h.85.
-  Stahlbalken, Achsenabstand 110 mm, mit Gewindeanschluss UNI ISO 228 und Anbauplatte für Dübel h.85.
-  Traversa en hierro, distancia 110 mm con anillo roscado/rosca UNI ISO 228 y soporte h.85 por juegos d'expansion.

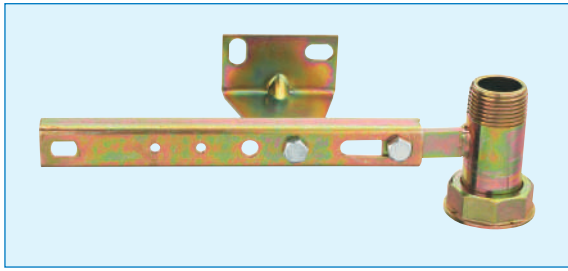

ØD x Ød	BOX	MASTER BOX	CODICE CODE	A
1" X 1 1/4	-	25	9F66290000	70,5



Art. 9F21



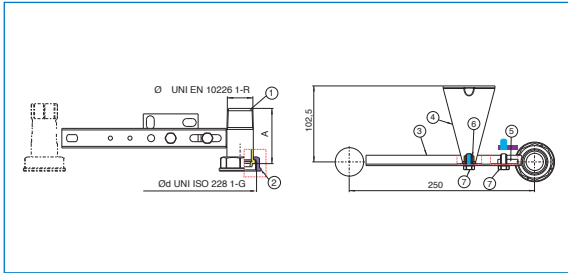

-  Traversa in acciaio, interasse 250 mm con canotto, filettatura ISO 7/1 e zanca triangolare per tasselli ad espansione.
-  Steel cross beam, center distance 250 mm, with threaded union tail ISO 7/1 and triangular fixing plate for raw plugs.
-  Traverse en acier, entre-axes 250 mm, avec raccord, taraudée ISO 7/1, avec support triangulaire pour vis murale.
-  Stahlbalken, Achsenabstand 250 mm, mit Gewindeanschluss ISO 7/1 und mit dreieckiger Anbauplatte für Dübel.
-  Traversa en hierro, distancia 250 mm con anillo roscado/rosca ISO 7/1 y soporte triangular por juegos d'expansion.

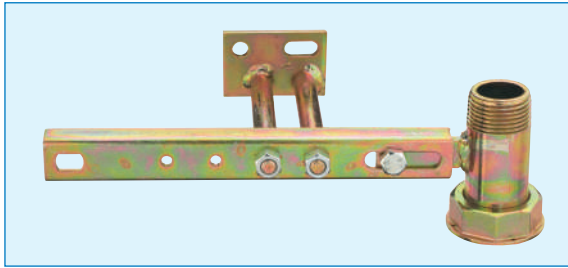

ØD x Ød	BOX	MASTER BOX	CODICE CODE	A
1" X 1"1/4	-	25	9F21290000	70,5



Art. 9F22



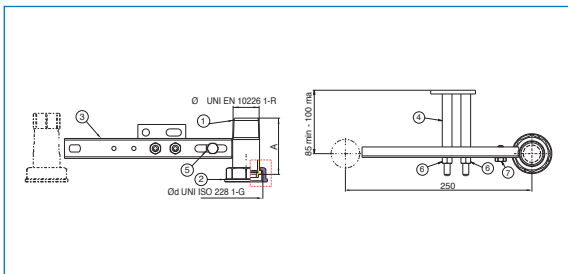

-  Traversa in acciaio, interasse 250 mm con canotto, filettatura ISO 7/1 e zanca a due colonne per tasselli ad espansione.
-  Steel cross beam, center distance 250mm, with threaded union tail ISO 7/1 and fixing plate for raw plugs.
-  Traverse en acier, entre-axes 250 mm, avec raccord, taraudée ISO 7/1, avec support pour vis murale.
-  Stahlbalken, Achsenabstand 250 mm, mit Gewindeanschluss ISO 7/1 und mit Anbauplatte für Dübel.
-  Traversa en hierro, distancia 250 mm con anillo roscado/rosca ISO 7/1 y soporte a dos columnas por juegos d'expansion.

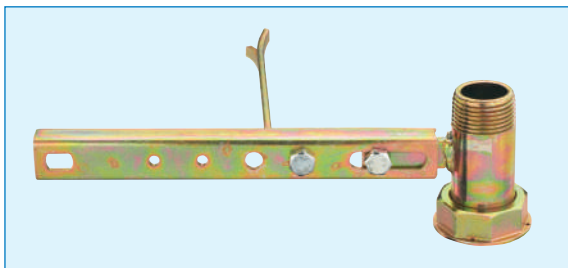

ØD x Ød	BOX	MASTER BOX	CODICE CODE	A
1" X 1"1/4	-	25	9F22290000	70,5



Art. 9F24

-  Traversa in acciaio, interasse 250 mm con canotto, filettatura ISO 7/1 e zanca a murare.
-  Steel cross beam, center distance 250 mm, with threaded union tail ISO 7/1 and wall up fixing plate.
-  Traversa en acier, entre-axes 250 mm, avec raccord, taraudée ISO 7/1, avec support mural.
-  Stahlbalken, Achsenabstand 250 mm, mit Gewindeanschluss ISO 7/1 und mit Anbauplatte zum einmauern.
-  Traversa en acero con distancia de 250 mm con anillo roscado/rosca ISO 7/1 sin Soporte a murar.

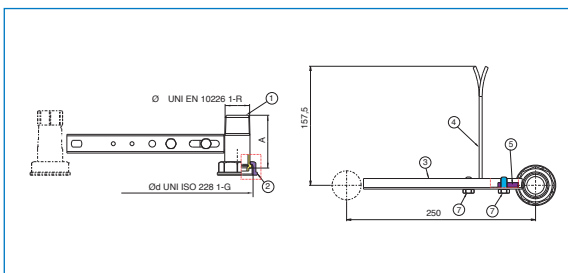





ØD x Ød	BOX	MASTER BOX	CODICE CODE	A
1" X 1"1/4	-	25	9F24290000	70,5

ACCOPIABILI CON LE VALVOLE DI PAGG.142-143 - TO BE USED ALONG WITH THE VALVES AT PAGES 142-143

POS.	DENOMINAZIONE	PART NAME	DESCRIPTION	TEILBENENNUNG	DENOMINACION	MATERIALE-MATERIALS MATERIAUX-WERKSTOFF-MATERIAL	TRATTAMENTO - TREATMENT	N°P
1	CANNOTTO	UNION TAIL	RACCORD	GEWINDEANSCHLUSS	RACCORD UNION	OTTONE CW 617 UNI EN 12165	SABBIATURA	1
2	GIRELLO	NUT	ECROU	VERSCHRAUBRING	TUERCA LOCA	OTTONE CW 617 UNI EN 12165	ZINCOTROPICALIZZAZIONE GIALLA	1
3	TRAVERSA	BEAM	TRAVERSE	BALKEN	TRAVERSA	ACCIAIO S235JR UNI EN 10025	ZINCOTROPICALIZZAZIONE GIALLA	1
4	ZANCA	SUPPORT	SUPPORT	LAGER	SOPORTE	ACCIAIO S235JR UNI EN 10025	ZINCOTROPICALIZZAZIONE GIALLA	1
5	GHIERA	RING	BAGUE	RING	ANILLO ROSCADO	OTTONE CW 614 UNI EN 12164	SABBIATURA	1
6	TAPPO	CAP	BOUCHON	KAPPE	TAPÓN	OTTONE CW 614 UNI EN 12164	SABBIATURA	1
7	O-RING	O-RING	O-RING	O-RING	O-RING	NBR	-	1
8	DADO	NUT	ECROU	MUTTER	TUERCA	ACCIAIO	ZINCATURA	1
9	VITE	SCREW	VIS	SCHRAUBE	TORNILLO	ACCIAIO	ZINCATURA	2
10	CANNOTTO	UNION TAIL	RACCORD	GEWINDEANSCHLUSS	RACCORD UNION	ACCIAIO S235JR UNI EN 10025	ZINCOTROPICALIZZAZIONE GIALLA	1



Art. 9F40



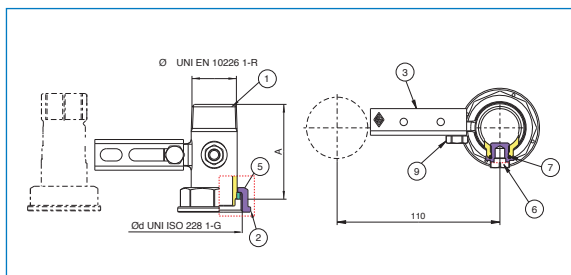

-  Traversa in acciaio, interasse 110 mm con canotto in ottone e presa pressione, filettatura ISO 7/1, senza zanca.
-  Steel cross beam, center distance 110 mm, with brass threaded ISO 7/1 union tail and pressure measurement connection, without fixing plate.
-  Traverse en acier, entre-axes 110 mm, avec raccord en laiton et prise de pression, taraudée ISO 7/1, sans support.
-  Stahlbalken, Achsenabstand 110 mm, mit Gewindeanschluss ISO 7/1 und Anschluss für Druckmessung, ohne Anbauplatte.
-  Traversa en acero, distancia 110 mm con anillo roscado en latón y conexión presión/rosca ISO 7/1 sin soporte.



Ød x Ød	BOX	MASTER BOX	CODICE CODE	A
1" X 1"1/4	-	25	9F40290000	69,5



Art. 9F41

-  Traversa in acciaio, interasse 110 mm con canotto in ottone e presa pressione, filettatura ISO 7/1, zanca triangolare per tasselli ad espansione.
-  Steel cross beam, center distance 110 mm, with brass threaded ISO 7/1 union tail and pressure measurement connection, triangular fixing plate.
-  Traverse en acier, entre-axes 110 mm, avec raccord en laiton et prise de pression, taraudée ISO 7/1, avec support triangulaire pour vis murale.
-  Stahlbalken, Achsenabstand 110 mm, mit Gewindeanschluss ISO 7/1 und Anschluss für Druckmessung, mit dreieckiger Anbauplatte.
-  Traversa en acero, distancia 110 mm con anillo roscado en latón y conexión presión/rosca ISO 7/1 y soporte triangular con juegos d'expansion.

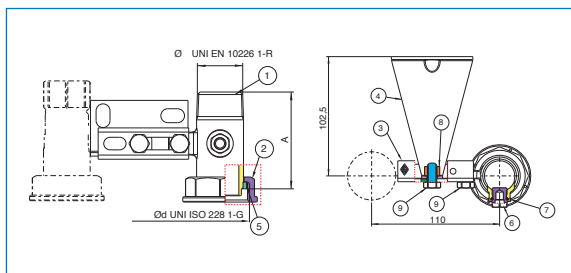

Ød x Ød	BOX	MASTER BOX	CODICE CODE	A
1" X 1"1/4	-	25	9F41290000	69,5

ACCOPIABILI CON LE VALVOLE DI PAGG.142-143 - TO BE USED ALONG WITH THE VALVES AT PAGES 142-143



Art. 9F44



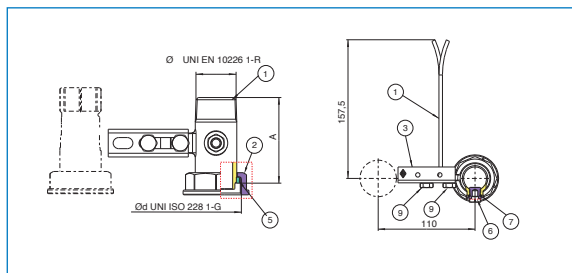

-  Traversa in acciaio, interasse 110 mm con canotto in ottone e presa pressione, filettatura ISO 7/1, zanca a murare.
-  Steel cross beam, center distance 110 mm, with brass threaded ISO 7/1 union tail and pressure measurement connection, built-in fixing plate.
-  Traverses en acier, entre-axes 110 mm, avec raccord en laiton prise de pression, taraudée ISO 7/1, avec support mural.
-  Stahlbalken, Achsenabstand 110 mm, mit Gewindeanschluss ISO 7/1 und Anschluss für Druckmessung, mit Anbauplatte zum einmauern.
-  Traversa en acero, distancia 110 mm con anillo roscado en latón y conexión presión/rosca ISO 7/1 soporte a embutir.



ØD x Ød	BOX	MASTER BOX	CODICE CODE	A
1" X 1"1/4	-	25	9F44290000	69,5



Art. 9F50

-  Traversa in acciaio, interasse 110 mm con canotto presa pressione, filettatura ISO 7/1, senza zanca.
-  Steel cross beam, center distance 110 mm, with threaded union tail for pressure measurement ISO 7/1, without fixing plate.
-  Traverses en acier, entre-axes 110 mm, avec raccord en laiton et prise de pression, taraudée ISO 7/1, sans support.
-  Stahlbalken, Achsenabstand 110 mm, mit Gewindeanschluss für Druckmessung ISO 7/1 ohne Anbauplatte.
-  Traversa en acero 110 mm con anillo roscado por contacto presión, roscas ISO 7/1 sin soporte.

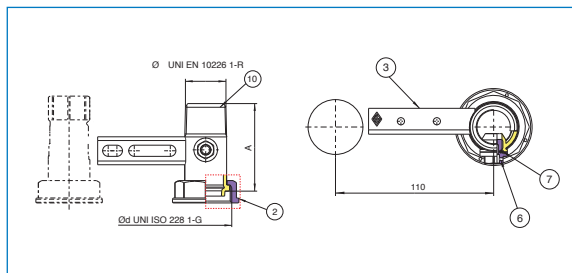

ØD x Ød	PRESA PRESSIONE	BOX	MASTER BOX	CODICE CODE	A
1" X 1"1/4	1/4	-	25	9F50290000	70
1" X 1"1/4	1/8	-	25	9F50290001	70



Art. 9F51

-  Traversa in acciaio interasse 110 mm, con canotto presa pressione filettatura ISO 7/1, zanca triangolare per tasselli ad espansione.
-  Steel cross beam, center distance 110 mm, with threaded ISO 7/1 union tail and pressure measurement connection, triangular fixing plate for raw plugs.
-  Traverses en acier, entre-axes 110 mm, avec raccord en laiton et prise de pression, taraudée ISO 7/1, avec support triangulaire pour vis murale.
-  Stahlbalken, Achsenabstand 110 mm, mit Gewindeanschluss ISO 7/1 und Anschluss für Druckmessung, mit dreieckiger Anbauplatte für Dübel.
-  Traversa en acero, distancia 110 mm con anillo roscado y conexión presión/rosca ISO 7/1 y soporte triangular con juegos d'expansion.

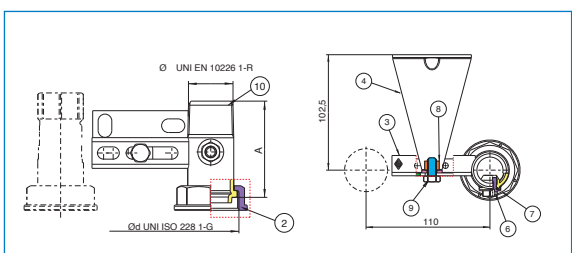



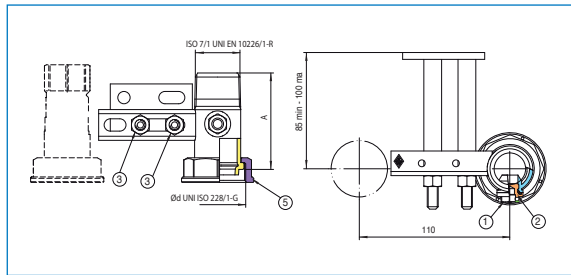

ØD x Ød	PRESA PRESSIONE	BOX	MASTER BOX	CODICE CODE	A
3/4" X 1"1/4	1/8	-	25	9F51280000	72
1" X 1"1/4	1/4	-	25	9F51290000	70

ACCOPIABILI CON LE VALVOLE DI PAGG.142-143 - TO BE USED ALONG WITH THE VALVES AT PAGES 142-143





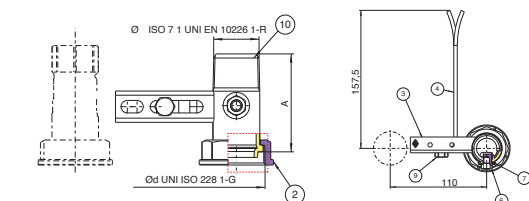

Art. 9F52

-  Traversa in acciaio interasse 110 mm, con canotto presa pressione filettatura ISO 7/1, zanca a due colonne.
-  Steel cross beam, center distance 110 mm, with threaded ISO 7/1 union tail and pressure measurement connection, avec support a deux colonnes.
-  Traverse en acier, entre-axes 110 mm, avec raccord en laiton et prise de pression, taraudée ISO 7/1, avec support a deux colonnes.
-  Doppelt Stahlbalken, Achsenabstand 110 mm, mit Gewindesnaschluss ISO 7/1 und Anschluss für Druckmessung.
-  Traversa en acero, distancia 110 mm con anillo roscado y conexión presión/rosca ISO 7/1 soporte con dos columnas.

ØD x Ød	BOX	MASTER BOX	CODICE CODE	A
1" X 1"1/4	-	25	9F52290000	70,5



Art. 9F54



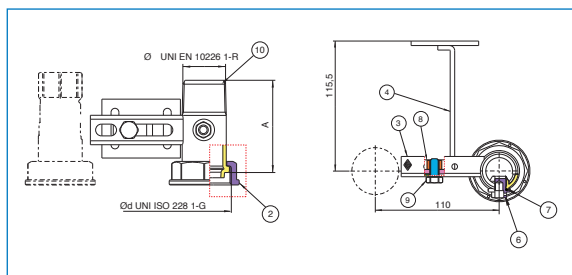

-  Traversa in acciaio interasse 110 mm, con canotto presa pressione filettatura ISO 7/1, zanca a murare.
-  Steel cross beam, center distance 110 mm, with threaded union tail for pressure measurement ISO 7/1, wall up fixing plate.
-  Traverse en acier, entre-axes 110 mm, avec prise de pression, taraudée ISO 7/1, avec support mural.
-  Stahlbalken, Achsenabstand 110 mm, mit Gewindeanschluss für Druckmessung ISO 7/1 mit Anbauplatte zum einmauern.
-  Traversa en acero 110 mm, con anillo roscado por contacto presión, roscas ISO 7/1 soporte a murar.

ØD x Ød	BOX	MASTER BOX	CODICE CODE	A
1" X 1"1/4	-	25	9F54290000	70,5

ACCOPIABILI CON LE VALVOLE DI PAGG.142-143 - TO BE USED ALONG WITH THE VALVES AT PAGES 142-143





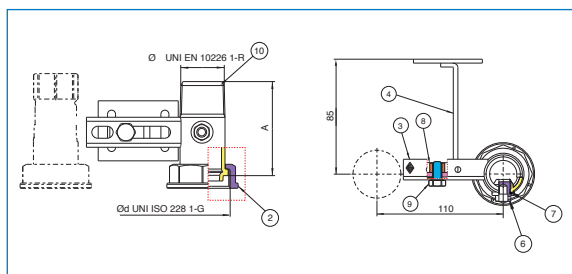

Art. 9F55

-  Traversa in acciaio, interasse 110 mm con canotto presa pressione, filettatura ISO 7/1 e zanca h.115 per tasselli ad espansione.
-  Steel cross beam, center distance 110 mm, with threaded union tail ISO 7/1 and fixing plate h.115 for raw plugs.
-  Traverses en acier, entre-axes 110 mm, avec raccord et prise de pression, taraudée ISO 7/1, avec support pour vis murale h.115.
-  Stahlbalken, Achsenabstand 110 mm, mit Gewindeanschluss ISO 7/1 und Anschluss für Druckmessung und Anbauplatte für Dübel h.115.
-  Traversa en hierro, distancia 110 mm con anillo roscado/rosca ISO 7/1 y conexión presión h.115 por juegos d'expansion.

Ød x Ød	BOX	MASTER BOX	CODICE CODE	A
1" X 1"1/4	-	25	9F55290000	70,5



Art. 9F56

-  Traversa in acciaio, interasse 110 mm con canotto presa pressione, filettatura ISO 7/1 e zanca h.85 per tasselli ad espansione.
-  Steel cross beam, center distance 110 mm, with threaded union tail ISO 7/1 and fixing plate h.85 for raw plugs.
-  Traverses en acier, entre-axes 110 mm, avec raccord et prise de pression, taraudée ISO 7/1, avec support pour vis murale h.85.
-  Stahlbalken, Achsenabstand 110 mm, mit Gewindeanschluss ISO 7/1 und Anschluss für Druckmessung und Anbauplatte für Dübel h.85.
-  Traversa en hierro, distancia 110 mm con anillo roscado/rosca ISO 7/1 y conexión presión h.85 por juegos d'expansion.

Ød x Ød	BOX	MASTER BOX	CODICE CODE	A
1" X 1"1/4	-	25	9F56290000	70,5

ACCOPIABILI CON LE VALVOLE DI PAGG.142-143 - TO BE USED ALONG WITH THE VALVES AT PAGES 142-143

Art. 9F48

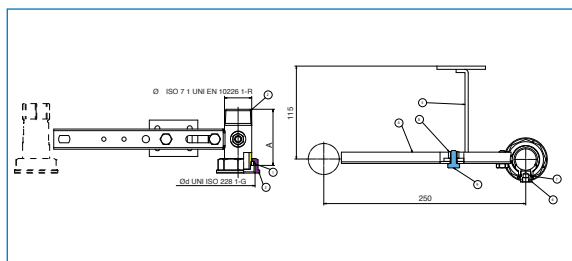
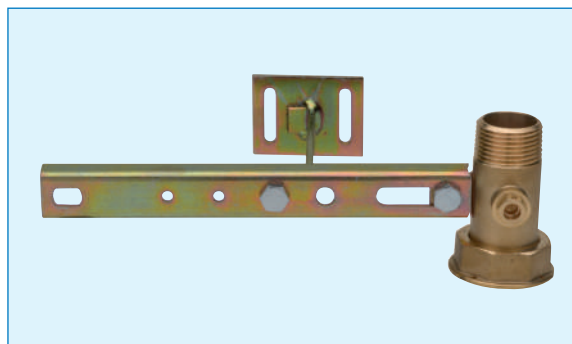

-  Traversa in acciaio interasse 250 mm, con canotto in ottone e presa pressione filettatura ISO 7/1, zanca h.115 per tasselli ad espansione.
-  Steel cross beam, center distance 250 mm, with threaded ISO 7/1 union tail and pressure measurement connection, fixing plate h.115 for raw plugs.
-  Traverse en acier, entre-axes 250 mm, avec raccord en laiton et prise de pression, taraudée ISO 7/1, avec support pour vis murale h.115.
-  Stahlbalken, Achsenabstand 250 mm, mit Gewindeanschluss ISO 7/1 und Anschluss für Druckmessung, Anbauplatte für Dübel h.115.
-  Traversa en acero, distancia 250 mm con anillo roscado y conexión presión/rosca ISO 7/1, h.115 por juegos d'expansion.

ØD x Ød	BOX	MASTER BOX	CODICE CODE	A
1" X 1"1/4	-	25	9F48290000	69,5

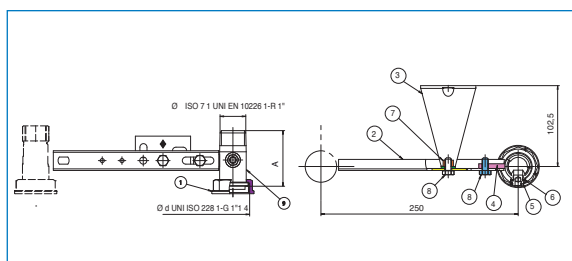
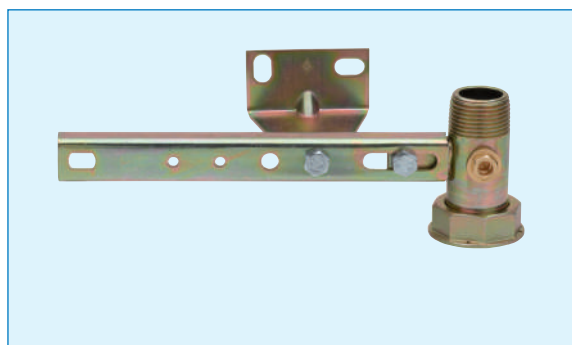

Art. 9F71

-  Traversa in acciaio interasse 250 mm, con canotto presa pressione filettatura ISO 7/1, zanca triangolare per tasselli ad espansione.
-  Steel cross beam, center distance 250 mm, with threaded ISO 7/1 union tail and pressure measurement connection, triangular fixing plate for raw plugs.
-  Traverse en acier, entre-axes 250 mm, avec raccord en laiton et prise de pression, taraudée ISO 7/1, avec support triangulaire pour vis murale.
-  Stahlbalken, Achsenabstand 250 mm, mit Gewindeanschluss ISO 7/1 und Anschluss für Druckmessung, mit dreieckiger Anbauplatte für Dübel.
-  Traversa en acero, distancia 250 mm con anillo roscado y conexión presión/rosca ISO 7/1 y soporte triangular con juegos d'expansion.

ØD x Ød	BOX	MASTER BOX	CODICE CODE	A
1" X 1"1/4	-	25	9F71290000	70,5

serie FIDO-SFER

Art. 967 C



- Valvola a sfera per contatore gas, con attacco per ferro mensola, con serratura di sicurezza e morosità, estraibile e sostituibile.
- Ball valve with security lock for gas meter with connection for meter bracket.
- Robinet à boisseau sphérique pour compteur à gaz, avec connexion pour console en fer, avec serrure de sécurité, extractible et remplaçable.
- Gas Kugelhahn mit abschliessbarem Flügelgriff für Gaszähler mit Anschluss für Gaszählerplatte.
- Válvula esfera por medidor gas con conexión por hierro ménsula, con cerradura de seguridad y morosidad extractable y sustituible.

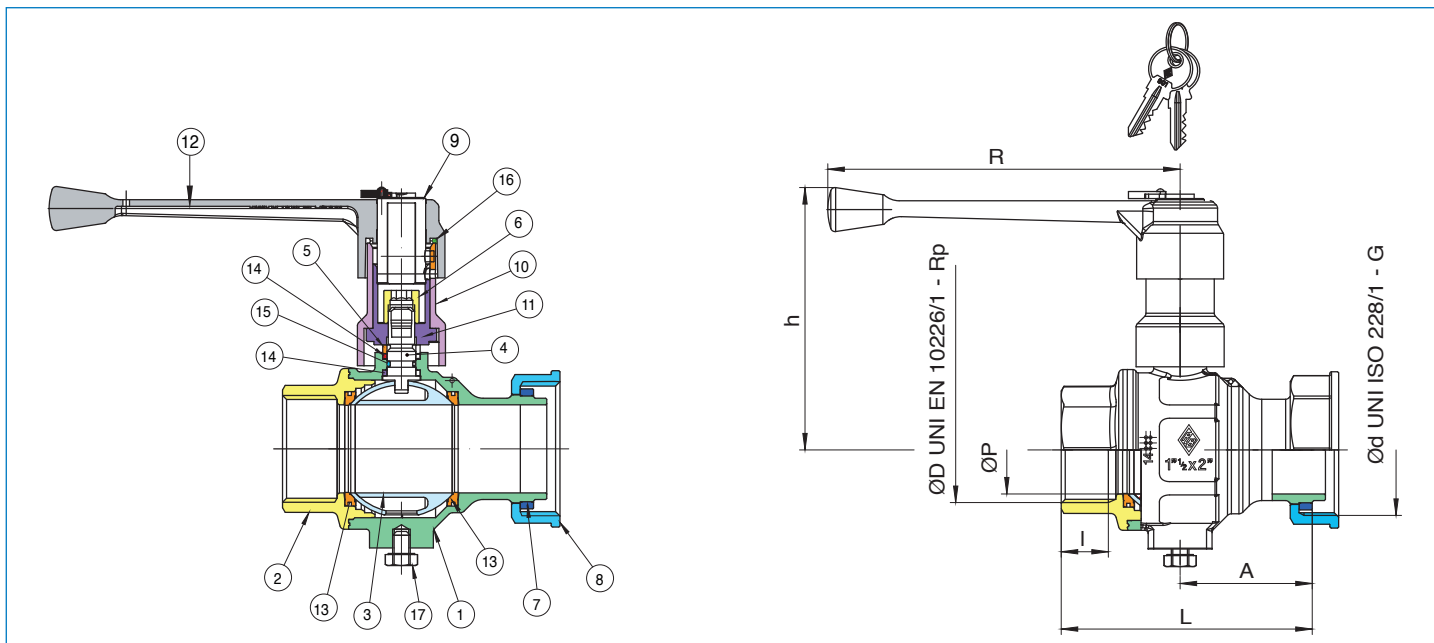





POS.	DENOMINAZIONE	PART NAME	DESCRIPTION	TEILBENENNUNG	DENOMINACION	MATERIALE-MATERIALS MATERIAUX-WERKSTOFF- MATERIAL	N°P
1	CORPO	BODY	CORPS	GEHÄUSE	CUERPO	OTTONE CW 617N UNI EN 12165	1
2	MANICOTTO	END CONNECTION	MANCHON	MUFFE	MANGUITO	OTTONE CW 617N UNI EN 12165	1
3	SFERA	BALL	BILLE	KUGEL	ESFERA	OTTONE CW 612N UNI EN 12165	1
4	ASTA	STEM	TIGE	DICHTUNG	EJE	OTTONE CW 614N UNI EN 12164	1
5	BUSSOLA PREMIGUARNIZIONE	PACKING GLAND	BAGUE DE PRESSURE ETOUPE	VORSPANNRING	ANILLO PRENSAESTOPA	OTTONE CW 614N UNI EN 12164	1
6	GHIERA	RING NUT	RACCORD	RING	ANILLO ROSCADO	OTTONE CW 617N UNI EN 12165	1
7	GHIERA	RING NUT	RACCORD	RING	ANILLO ROSCADO	OTTONE CW 614N UNI EN 12168	1
8	GIRELLO	NUT	ECROU	VERSCHRAUBRING	TUERCA LOCA	OTTONE CW 617N UNI EN 12165	1
9	SERRATURA	LOCK PROTECTION	SERRURE	SCHLOSSABDECKUNG	CERRADURA	PAmxD6	1
10	COPRI SERRATURA	CAP	COUVRE-SERRURE	KAPPE	TAPÓN CERRADURA	OTTONE CW 614N UNI EN 12164	1
11	COPRI SERRATURA	CAP	COUVRE-SERRURE	KAPPE	TAPÓN CERRADURA	OTTONE CW 614N UNI EN 12164	1
12	LEVA	HANDLE	PIOGNÉE	HANDHEBEL	PALANCA	ALLUMINIO	1
13	GUARNIZIONE SFERA	BALL SEAT	JOINT DE TENUE BILLE	KUGELDICHTUNG	JUNTA ESFERA	P.T.F.E.	2
14	GUARNIZIONE ASTA	STEM SEAL	LOINT DE L'AXE	STOBHEMMENDE	JUNTA EJE	P.T.F.E.	2
15	O-RING	O-RING	O-RING	O-RING	O-RING	NBR	1
16	O-RING	O-RING	O-RING	O-RING	O-RING	MVQ	1
17	VITE	SCREW	SERRURE	SCHLOSS	CERRADURA	ACCIAIO CL 8.8	1

MISURE SIZE	BOX	MASTER BOX	CODICE CODE	ØP	l	Ch	L	h	A	R	MOP	Kg
1" 1/2 X 2"	-	5	967C690925	40	21,4	63	114	119	60	160	5	1,21
2" X 2" 1/2	-	5	967C700925	49,5	25,7	67	131	128	67,5	160	5	2,65

Limiti di temperatura: -20°C +60°C - Temperature range: -20°C +60°C.

Art. 946 C



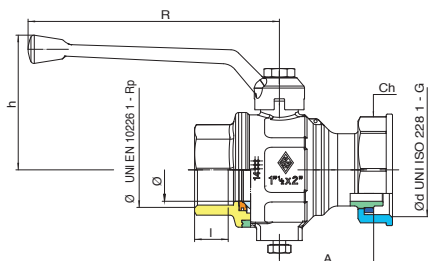

-  Valvola a sfera a passaggio totale per contatore gas, con attacco per ferro mensola. Ingresso femmina e leva in alluminio.
-  Full bore ball valve for gas meter, with connection for meter bracket. Female inlet with aluminum handle.
-  Robinet à boisseau sphérique à passage total pour compteur gaz, avec connexion pour console en fer. Entrée taraudé et poignée en aluminium.
-  Kugelhahn für Gaszähler mit vollem Durchgang, mit Anschluss für gaszählerplatte. IG Anschluss und Aluminium Hebel.
-  Valvula esfèra para medidor de gas, con conexi3n poe hierro m3nsula, paso total, entrada hembra, palanca de aluminio.



ØD x Ød	BOX	MASTER BOX	CODICE CODE	ØP	I	Ch	L	h	A	R	MOP	Kg
1" 1/2 x 2"	-	5	946C690000	40	21,4	63	114	86	60	160	5	0,90

Limiti di temperatura: -20°C +60°C - Temperature range: -20°C +60°C.



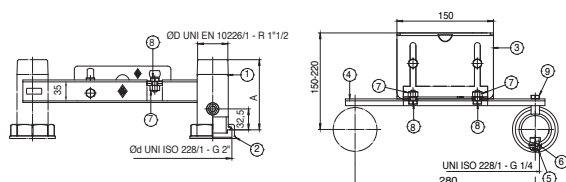
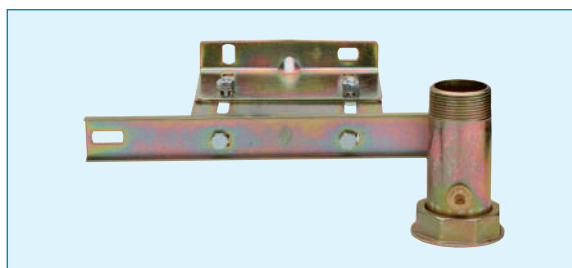

Art. 9F33

-  Traversa in acciaio con canotto filettato UNI EN 10226/1 e presa pressione UNI ISO 228/1 G 1/4", zanca a muro regolabile per contatori G10-G16.
-  Steel cross beam with threaded UNI EN10226/1 union and UNI ISO 228/1 G 1/4" pressure measurement connection, adjustable fixing plate for gas meter G10-G16.
-  Traverse en acier avec raccord taraudé UNI EN 10226/1 et prise de pression UNI ISO 228/1 G 1/4", support mural réglable pour compteur G10-G16.
-  Stahlbalken mit Gewindeanschluss nach UNI EN 10226/1 und Anschluss nach UNI ISO 228/1 G 1/4" für Druckmessung, justierbare Anbaublatt für Zähler G10-G16.
-  Traversa en acero con amillo roscado UNI EN 10226/1 y conexi3n presi3n UNI ISO 228/1 G 1/4", soporte ajustable por medidor G10-G16.



ØD x Ød	BOX	MASTER BOX	CODICE CODE	A	B	C	Lmin	Lmax	Kg
1"1/2 X 2"	-	5	9F33690000	109	280	150	150	220	1,77

Art. 9F33

-  Traversa in acciaio, con canotto filettato UNI EN 10226/1 e presa pressione UNI ISO 228/1 G 1/4", zanca a muro regolabile per contatori G10-G16-G25.
-  Steel cross beam, with threaded UNI EN10226/1 union and UNI ISO 228/1 G 1/4" pressure measurement connection, adjustable fixing plate for gas meter G10-G16-G25.
-  Traverse en acier, b avec raccord taraudé UNI EN 10226/1 et prise de pression UNI ISO 228/1 G 1/4", support mural réglable pour compteur G10-G16-G25.
-  Stahlbalken, mit Gewindeanschluss nach UNI EN 10226/1 und Anschluss nach UNI ISO 228/1 G 1/4" für Druckmessung, justierbare Anbaublatt für Zähler G10-G16-G25.
-  Traversa en acero, con amillo roscado UNI EN 10226/1 y conexi3n presi3n UNI ISO 228/1 G 1/4", por medidor G10-G16-G25.

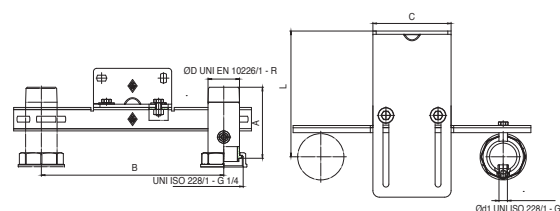
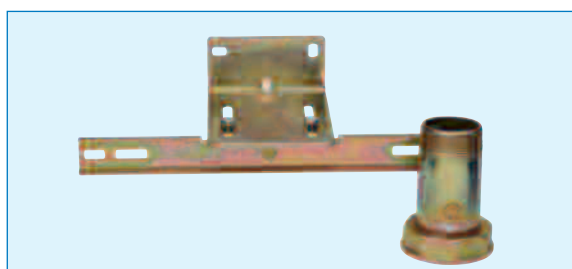

ØD x Ød	BOX	MASTER BOX	CODICE CODE	A	B	C	Lmin	Lmax	Kg
1"1/2 X 2"	-	10	9F33690001	109	280	120	195	305	2,45
2" x 2"1/2	-	10	9F33700000	109	335	120	195	305	2,78



Art. 9463

- Adattatore eccentrico per contatore gas, interasse 33-77 mm.
- Eccentric adapter for gas meter, 33-77 mm center distance.
- Adaptateur pour compteur gaz, entre-axes 33-77 mm.
- Ekzentrischer Adapter für Gaszähler, Breite 33-77 mm.
- Adaptador excéntrico para medidor de gas, distancia 33-77 mm.

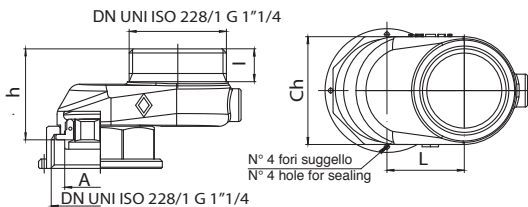

ØD x Ød	BOX	MASTER BOX	CODICE CODE	ØA	Ch	L	l	h	Kg
1"1/4 x 1"1/4	30	60	9463290002	30,5	46	33	14	38,8	0,34
1"1/4 x 1"1/4	30	60	9463290003	30,5	46	77	14	38,8	0,46



Art. 9563

- Adattatore eccentrico per contatore gas con presa pressione, interasse 33-77 mm).
- Eccentric adapter for gas meter with pressure measurement connection, 33-77 mm center distance.
- Adaptateur pour compteur à gaz avec de prise pression, entre-axes 33-77 mm Ekzentrische.
- Gaszähler Adapter mit Anschluss für Druckmessung, Breite 33-77 mm.
- Adaptador excéntrico por medidor gas y conexión medición presión, distancia 33-77 mm.

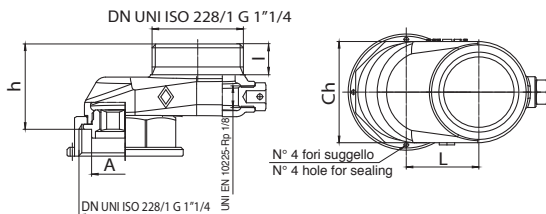

ØD x Ød	BOX	MASTER BOX	CODICE CODE	ØA	Ch	L	l	h	Kg
1"1/4 x 1"1/4	30	60	9563290002	30,5	46	33	14	38,8	0,33
1"1/4 x 1"1/4	30	60	9563290003	30,5	46	77	14	38,8	0,45



Art. 9463



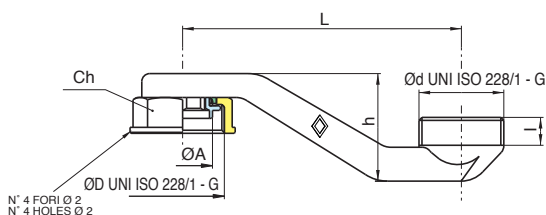

- Adattatore per contatore gas (interasse 110-250 mm).
- Adapter for gas meter (110-250 mm center distance).
- Adaptateur pour compteur à gaz (entre-axes 110-250 mm).
- Gaszähler Adapter (Breite 110-250 mm).
- Adaptador por medidor gas y eje (distancia 110-250 mm).



ØD x Ød	BOX	MASTER BOX	CODICE CODE	ØA	Ch	l	L	h
1"1/4 x 1"1/4	20	40	9463350000	30,5	46	14	140	54

Art. 9563





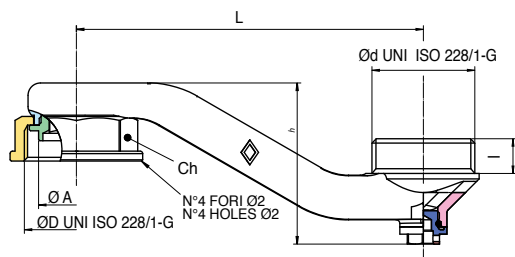

-  Adattatore per contatore gas con presa pressione (interasse 110-250 mm).
-  Adapter for gas meter with pressur measurement connection (110-250 mm center distance).
-  Adapteur pour compteur à gaz avec de prise pression (entre-axes 110-250 mm).
-  Gaszähler Adapter mit Anschluss für Druckmessung (Breite 110-250 mm).
-  Adaptador por medidor gas y medición de la presión (distancia 110-250 mm).



ØD x Ød	BOX	MASTER BOX	CODICE CODE	ØA	Ch	l	L	h
1"1/4 x 1"1/4	20	40	9563350000	30,5	46	14	140	65



Art. 9463



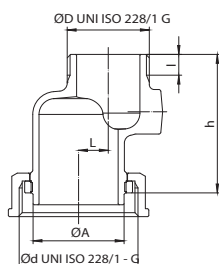

-  Adattatore eccentrico per contatore gas (interasse 250-280 mm).
-  Eccentric adapter for gas meter (250-280 mm center distance).
-  Adapteur pour compteur gaz (entre-axes 250-280 mm).
-  Ekzentrischer Adapter für Gaszähler (Breite 250-280 mm).
-  Adaptador excéntrico para medidor de gas (distancia 250-280 mm).



ØD x Ød	BOX	MASTER BOX	CODICE CODE	ØA	Ch	l	L	h	Kg
1"1/4 x 2"	6	12	9463630001	46	63	10,5	15	70	0,59
2" x 2"	6	12	9463720001	46	63	13	15	70	0,72



Art. 9563



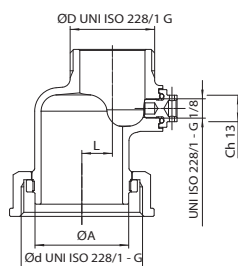

-  Adattatore eccentrico per contatore gas con presa pressione (interasse 250-280 mm).
-  Eccentric adapter for gas meter with pressure measurement connection (250-280 mm center distance).
-  Adapteur pour compteur à gaz avec de prise pression (entre-axes 250-280 mm).
-  Ekzentrischer Gaszähler Adapter mit Anschluss für Druckmessung (Breite 250-280 mm).
-  Adaptador excéntrico por medidor gas y conexion medicion presión (distancia 250-280 mm).

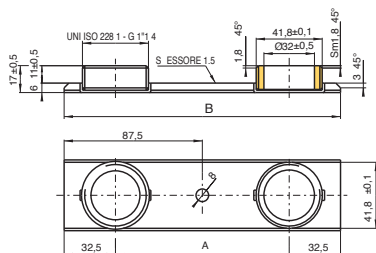

ØD x Ød	BOX	MASTER BOX	CODICE CODE	ØA	Ch	l	L	h	Kg
1"1/4 x 2"	6	12	9563630001	46	63	10,5	15	70	0,59
2" x 2"	6	12	9563720001	46	63	13	15	70	0,72





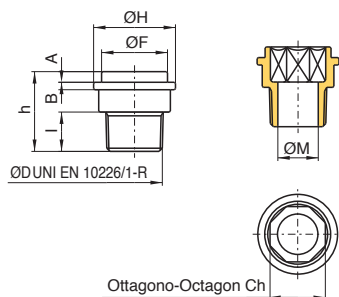

Art. 9467 •

-  Dima per contatore gas (interasse 110-335 mm).
-  Template for gas meter (110-335 mm center distance).
-  Support pour compteur à gaz (entre-axes 110-335 mm).
-  Anschlussvorrichtung für Gaszähler (Breite 110-335 mm).
-  Soporte por medidor gas (distancia 110-335 mm).

MISURA SIZE	BOX	MASTER BOX	CODICE CODE	A	B
1"1/4	25	50	9467070000	110	175
1"1/4	-	50	9467070250	250	315
2"	-	10	9467100280	280	355
2"1/2	-	10	9467120335	335	410





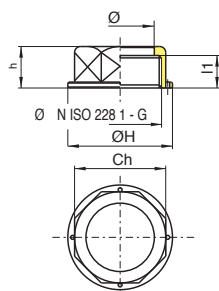

Art. 9571

-  Cannotto per contatore gas.
-  Union tail for gas meter.
-  Raccord pour compteur à gaz.
-  Verschraubung für Gaszähler.
-  Conexión por medidor gas.

MISURA SIZE	DN	BOX	MASTER BOX	CODICE CODE	A	B	ØF	ØH	h	ØM	l	Ch	Kg
3/4"	20	50	100	9571050000	5	3,5	31	38,5	37,5	19	18,5	28	0,09
1"	25	50	100	9571060000	5	3,5	331	38,5	41	25	19,1	-	0,11
1"1/2	40	15	30	9571080000	7	5	46	55	48	38	21,4	-	0,26
2"	50	10	20	9571100000	7	5	59	71	54	50	25,7	-	0,41







Art. 9574

-  Girello per contatore gas.
-  Ring nut for gas meter.
-  Écrou pour compteur à gaz.
-  Mutter für Gaszähler.
-  Tuerca loca por medidor gas.

MISURA SIZE	DN	BOX	MASTER BOX	CODICE CODE	ØH	l1	Ch	ØP	h	Kg
1"1/4	32	25	150	9574070000	52,8	14,5	46	34,5	18	0,09
2"	50	15	90	9574100000	71	18	63	49,5	22	0,15
2"1/2	65	10	20	9574120000	88	19,5	80	61	25	0,27

Art. 6667



-  Disco antimanomissione per contatore gas.
-  Anti tempering disc for gas meter.
-  Disque anti-manumission pour compteur gaz.
-  Flügelgriff Abdeckung - rot für Warmwasser, blau für Kaltwasser.
-  Disco anti-manipulación para contador de gas.

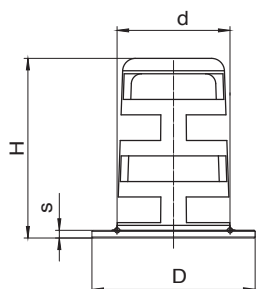

CONTATORE GAS METER	BOX	MASTER BOX	CODICE CODE	d	H	s	D
G4-G6	75	150	6667320000	22	35	1,5	31,8

serie FIDO-SFER

Art. 9099



Valvola a sfera per gas a passaggio totale diritta, post-contatore con punto presa pressione laterale, attacchi F/F e farfalla in alluminio.



Full bore ball valve, straight, after the meter with lateral pressure measurement connection, F/F threaded and T-handle.



Robinet à boisseau sphérique à passage total droite, après-compteur avec point de prise pression latérale, connections F/F et levier papillon.



Kugelhahn voller Durchgang, Montage nach dem Zähler, mit Anschluss für Druckmessung, beiderseits Innengewinde, mit Flügelgriff.



Valvula esfera a paso total directa, después medidor con punto de medición de la presión, conexión hembra/hembra y mariposa de maniobra.

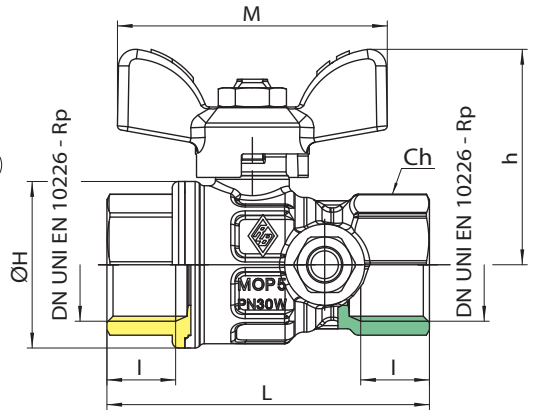
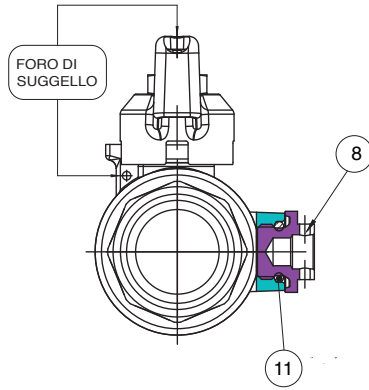
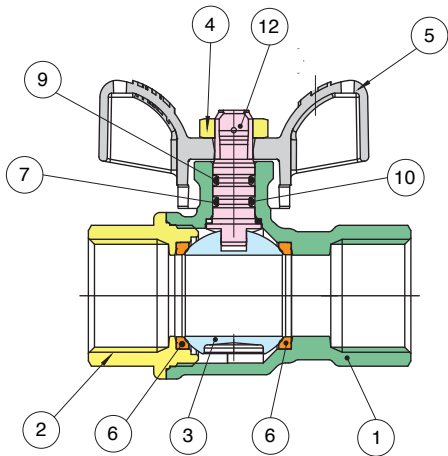





POS.	DENOMINAZIONE	PART NAME	DESCRIPTION	TEILBENENNUNG	DENOMINACION	MATERIALE-MATERIALS MATERIAUX-WERKSTOFF- MATERIAL	N°P
1	CORPO	BODY	CORPS	GEHÄUSE	CUERPO	OTTONE CW 617N UNI EN 12165	1
2	MANICOTTO	END CONNECTION	MANCHON	MUFFE	MANGUITO	OTTONE CW 617N UNI EN 12165	1
3	SFERA	BALL	BILLE	KUGEL	ESFERA	OTTONE CW 617N UNI EN 12165	1
4	ASTA	STEM	TIGE	DICHTUNG	EJE	OTTONE CW 614N UNI EN 12164	1
5	FARFALLA	T-HANDLE	POIGNÉE À PAPILLON	GRIFF	MARIPOSA	ALLUMINIO EN-AC 46100 EN 1706	1
6	GUARNIZIONE SFERA	BALL SEAT	JOINT DE TENUE BILLE	KUGELDICHTUNG	JUNTA ESFERA	P.T.F.E	2
7	GUARNIZ. ANTIATRITO	STEM SEAL/THRUST WASHER	JOINT L'AXE/ANTIFRICTION	STOßHEMMENDE DICHTUNG	JUNTA EJE/ANTIFRICCIÓN	P.T.F.E	1
8	TAPPO	CAP	BOUCHON	KAPPE	TAPON	OTTONE CW 614N UNI EN 12164	1
9	O-RING	O-RING	O-RING	O-RING	O-RING	FKM	1
10	O-RING	O-RING	O-RING	O-RING	O-RING	NBR	1
11	O-RING	O-RING	O-RING	O-RING	O-RING	NBR	1
12	DADO	NUT	ECROU	MUTTER	TUERCA	ACCIAIO CL 04	1

MISURE SIZE	BOX	MASTER BOX	CODICE CODE	I	Ch	ØH	L	h	M	MOP	Kg
3/4"	15	30	9099050000	16,3	31	39	76,5	51	64	5	0,37
1"	10	20	9099060000	19,1	38	49	91,5	54,5	64	5	0,57

Limiti di temperatura: -20°C +60°C - Temperature range: -20°C +60°C.

Art. 9097



-  Valvola a sfera per gas a passaggio totale diritta, post-contatore con punto presa pressione laterale, attacchi F/F e leva in alluminio.
-  Full bore ball valve, straight, after the meter with lateral pressure measurement connection, F/F threaded and handle.
-  Robinet à boisseau sphérique à passage total droite, après-compteur avec point de prise pression laterale, connexions F/F jaune en aluminium.
-  Kugelhahn voller Durchgang, Montage nach dem Zähler, mit Anschluss für Druckmessung, beiderseits Innengewinde, mit Aluminiumhebel.
-  Valvula esfera a paso total directa, después medidor con punto de medición de la presión, conexión hembra/hembra y aluminio amarilla.

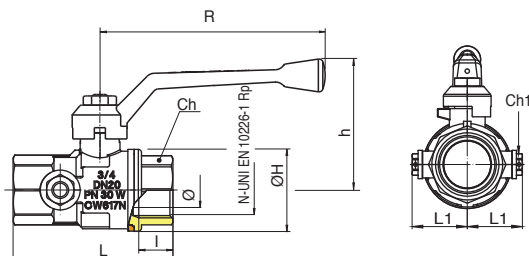





MISURE SIZE	DN	BOX	MASTER BOX	CODICE CODE	ØP	I	Ch	Ch1	ØH	L	L1	h	R	MOP	Kg
1"1/4	32	6	12	9097070000	32	19,1	48	13	59	103	37	79,5	160	5	0,88
1"1/2	40	6	12	9097080000	40	21,4	54	13	73	115	43	86	160	5	1,28
2"	49,5	4	8	9097100000	49,5	25,7	67	13	86	133	49	103	170	5	2,07

Limiti di temperatura: -20°C +60°C - Temperature range: -20°C +60°C.

Art. 9499



-  Valvola a sfera per gas a passaggio totale diritta, post-contatore con punto presa pressione di sicurezza, attacchi F/F e serratura di sicurezza.
-  Full bore ball valve, straight, after the meter with pressure measurement safety connection, F/F threaded, wit security lock.
-  Robinet à boisseau sphérique à passage total droite, après-compteur avec point de prise pression de sécurité, connexions F/F et et serrure de sécurité.
-  Kugelhahn voller Durchgang, Montage nach dem Zähler, mit Anschluss für Druckmessung, beiderseits Innengewinde, mit Flügelgriff.
-  Valvula esfera a paso total directa, después medidor con punto de medición de la presión en seguridad, conexión, hembra/hembra y cerradura de seguridad.

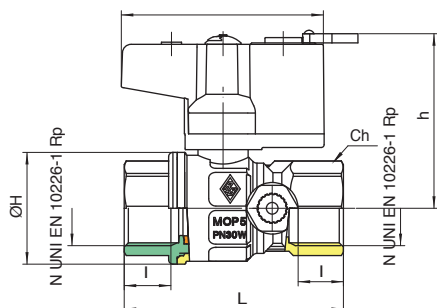





MISURE SIZE	DN	BOX	MASTER BOX	CODICE CODE	I	Ch	ØH	L	h	M	MOP	Kg
3/4"	20	-	25	9499050075	16,3	31	39	76,5	51	64	5	0,44
1"	25	-	25	9499060075	19,1	38	49	91,5	54,5	64	5	0,64

Limiti di temperatura: -20°C +60°C - Temperature range: -20°C +60°C.

Art. 9098



-  Valvola a sfera per gas passaggio totale a squadra, post-contatore con punto presa pressione, attacchi femmina/doppia filettatura F/M è fatta in alluminio.
-  Full bore ball valve, square, after the meter with pressure measurement connection, female/double thread F/M and T-handle.
-  Robinet à boisseau sphérique à passage total, à équerre, après-compteur avec point de prise pression, connexions femelles/double taraudage F/M et levier papillon.
-  Eck-Kugelhahn voller Durchgang, Montage nach dem Zähler, mit Anschluss für Druckmessung, einerseits Innengewinde, andererseits Aussengewinde, mit Flügelgriff.
-  Valvula esfera a paso total escuadra, después medidor con punto de medición de la presión, conexiones hembras/doble rosca hembra/macho, mariposa de maniobra.

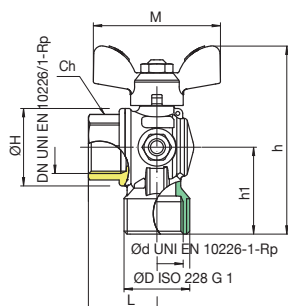



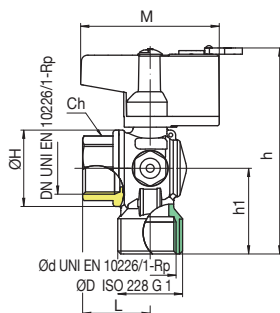

MISURA SIZE	DN	BOX	MASTER BOX	CODICE CODE	ØD	Ød	L	ØH	h	h1	Ch	M	MOP	Kg
3/4"	20	15	30	9098580000	1"	3/4	34,5	39	95	44	31	64	5	0,33
1"	25	10	20	9098300000	1"	3/4	42	49	101	47	38	64	5	0,50

Limiti di temperatura: -20°C +60°C - Temperature range: -20°C +60°C.



Art. 9498



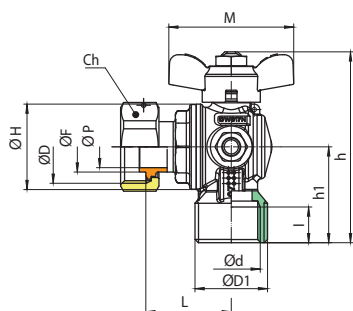

-  Valvola a sfera per gas a passaggio totale a squadra, post-contatore con presa pressione di sicurezza, attacchi femmina/doppia filettatura F/M e serratura di sicurezza.
-  Full bore ball valve, square, after the meter with pressure measurement safety connection, female/double thread F/M with security lock.
-  Robinet à boisseau sphérique à passage total, à équerre, après-compteur avec prise pression de sécurité, connexions femelles/double taraudage F/M et serrure de sécurité.
-  Eck-Kugelhahn voller Durchgang, Montage nach dem Zähler, mit Sicherheitsanschluss für Druckmessung, einerseits Innengewinde, andererseits Aussengewinde, mit Flügelgriff.
-  Valvula esfera a paso total escuadra, después medidor con sistema de medición de la presión en seguridad, conexiones hembras/doble rosca hembra/macho cerradura de seguridad.

MISURA SIZE	DN	BOX	MASTER BOX	CODICE CODE	ØD	Ød	L	ØH	h	h1	Ch	M	MOP	Kg
3/4"	20	-	25	9498580075	1"	3/4"	34,5	39	105,5	44	31	71	5	0,40
1"	25	-	25	9498300075	1"	3/4"	42	49	112	47	38	71	5	0,57

Limiti di temperatura: -20°C +60°C - Temperature range: -20°C +60°C.



Art. 9079



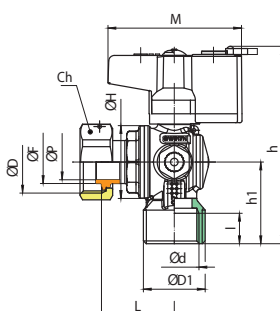

-  Valvola a sfera per gas a passaggio totale a squadra, post-contatore con presa pressione di sicurezza, attacchi girello 1"/doppia filettatura F/M e farfalla in alluminio.
-  Full bore ball valve, square, after the meter with safety pressure measurement point, connections nut 1" and double F/M threads and T-handle.
-  Robinet à boisseau sphérique à passage total, à équerre, après-compteur avec prise pression de sécurité, connexions écrou 1"/double taraudée F/M et poignée à papillon en aluminium.
-  Eckkugelhahn mit vollem Durchgang, Montage mit Zähler, mit Sicherheitsanschluss für Druckmessung, Anschlussmutter 1", Innen- und Außengewinde und Aluminiumflügelgriff.
-  Valvula esfera a paso total escuadra, después medidor con sistema de medición de la presión en seguridad, conexiones tuerca de 1"/rosca double hembra/macho y mariposa de aluminio.

ØD x Ød	DN	BOX	MASTER BOX	CODICE CODE	ØD1	ØP	I	L	ØH	h	h1	Ch	ØF	M	MOP	Kg
1" x 3/4"	20	15	30	9079580000	1"	19	16,3	39	39	87	43,7	37	23	57	5	0,41

Limiti di temperatura: -20°C +60°C - Temperature range: -20°C +60°C.



Art. 9479

-  Valvola a sfera per gas passaggio totale a squadra, post-contatore con presa pressione di sicurezza, attacchi girello 1"/doppia filettatura F/M e serratura di sicurezza.
-  Full bore ball valve, square, after the meter with pressure measurement point, connections nut 1" and double F/M threads and safety lock.
-  Robinet à boisseau sphérique à passage total, à équerre, après-compteur avec prise pression de sécurité, connexions écrou 1"/double taraudée F/M et serrure de sécurité.
-  Eckkugelhahn mit vollem Durchgang, Montage mit Zähler, mit Sicherheitsanschluss für Druckmessung, Anschlussmutter 1", Innen- und Außengewinde und Sicherheitsverschluss.
-  Valvula esfera a paso total escuadra, después medidor con sistema de medición de la presión en seguridad, seguridad, conexiones tuerca de 1"/rosca double macho/hembra cerradura de seguridad.

ØD x Ød	DN	BOX	MASTER BOX	CODICE CODE	ØD1	ØP	I	L	ØH	h	h1	Ch	ØF	M	MOP	Kg
1" x 3/4"	20	-	25	9479580075	1"	19	16,3	39	39	105,5	43,7	37	23	71	5	0,49

Limiti di temperatura: -20°C +60°C - Temperature range: -20°C +60°C.

Art. 9082

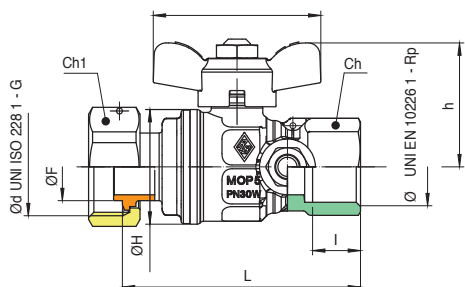
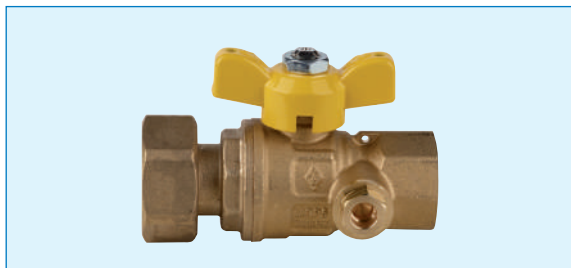

Valvola a sfera per gas a passaggio totale diritta, post-contatore con presa pressione di sicurezza, attacchi girello 1"/filettatura femmina e farfalla in alluminio.

Full bore ball valve, straight, after the meter with pressure measurement point, connections nut 1"/female threads and T-handle.

Robinet à boisseau sphérique à passage total, après-compteur avec point de prise pression, connexions écrou 1"/double taraudée F et poignée à papillon en aluminium.

Kugelhahn mit vollem Durchgang, Montage mit Zähler, mit Sicherheitsanschluss für Druckmessung, Anschlussmutter 1", Innengewinde und Aluminiumflügelgriff.

Válvula esfera a paso total, después medidor con sistema de medición de la presión en seguridad, conexiones tuerca de 1"/rosca hembra y mariposa en aluminio.

ØD x Ød	DN	BOX	MASTER BOX	CODICE CODE	I	L	ØH	Ch1	Ch	h	ØF	M	MOP	Kg
3/4" x 1"	20	15	30	9082580000	16,3	81	39	37	31	42	23	57	5	0,44

Limiti di temperatura: -20°C +60°C - Temperature range: -20°C +60°C.

Art. 9482

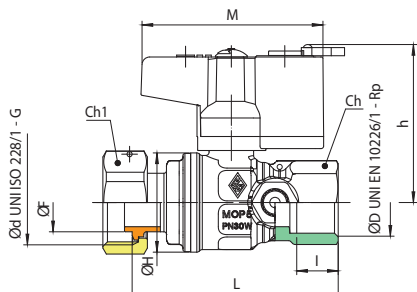

Valvola a sfera per gas a passaggio totale diritta, post-contatore con presa pressione di sicurezza, attacchi girello 1"/filettatura femmina e serratura di sicurezza.

Full bore ball valve, straight, after the meter with pressure measurement point, connections nut 1"/female threads and safety lock.

Robinet à boisseau sphérique à passage total, après-compteur avec point de prise pression, connexions écrou 1"/double taraudée F et serrure de sécurité.

Kugelhahn mit vollem Durchgang, Montage mit Zähler, mit Sicherheitsanschluss für Druckmessung, Anschlussmutter 1", Innengewinde und Sicherheitsverschluss.

Válvula esfera a paso total, después medidor con sistema de medición de la presión en seguridad, conexiones tuerca de 1"/rosca hembra y cerradura de seguridad.

ØD x Ød	DN	BOX	MASTER BOX	CODICE CODE	I	L	ØH	Ch1	Ch	h	ØF	M	MOP	Kg
3/4" x 1"	20	-	25	9482580075	16,3	81	39	31	37	62	23	71	5	0,51

Limiti di temperatura: -20°C +60°C - Temperature range: -20°C +60°C.

Art. 9493

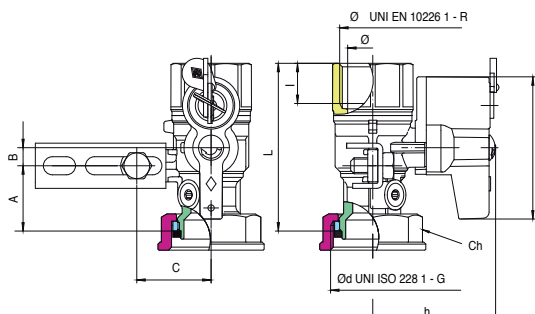
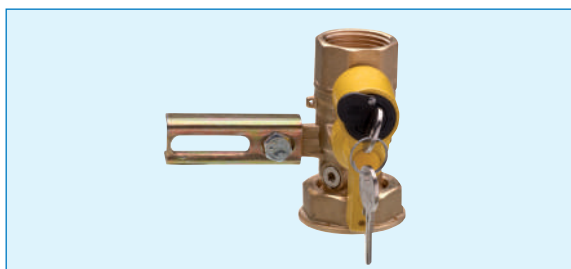

Valvola a sfera post-contatore, girello per collegamento diretto al contatore e presa pressione, con uscita F e serratura di sicurezza.

Full bore straight ball valve, after meter, with female nut for direct connection, pressure measurement connection, female thread and safety lock.

Vanne à boisseau sphérique passage intégral, après-compteur, écrou pour connexion directe, prise de pression, sortie femelle et verrou de sécurité.

Kugelhahn voller Durchgang, Montage nach dem Zähler, Überwurfmutter für direkten Anschluß, Druckmessung-Anschluß, Innengewinde und Sicherungsschloß.





Válvula esfera paso total, después medidor, tuerca loca de conexión directa, punto de medición presión, salida hembra y cerradura de seguridad.

ØD x Ød	BOX	MASTER BOX	CODICE CODE	ØP	I	Ch	L	h	A	B	C	M	MOP	Kg
1" x 1 1/4"	-	25	9493290075	20	19,1	46	83,5	61	32,5	9	37	70	5	0,64

Limiti di temperatura: -20°C +60°C - Temperature range: -20°C +60°C.



Art. 9094

-  Valvola a sfera passaggio totale, post-contatore, girello per collegamento diretto al contatore, con uscita M/F girevole (360°) con punto di presa pressione, farfalla in alluminio.
-  Full bore ball valve, after the meter, nut for direct connection to the meter and (360°) rotating male outlet, with pressure measurement safety connection and aluminium T-handle.
-  Robinet boisseau sphérique à passage intégral, après-compteur, écrou pour connexion directe au compteur, avec sortie tournante male (360°) et prise de pression de sécurité, manette papillon aluminium.
-  Kugelhahn voller Durchgang, Montage nach dem Zähler, Überwurfmutter für direkte Verbindung mit dem Zähler, (360°) drehbarer Anschluss mit Außengewinde, Sicherheitsanschluss für Druckmessung und Flügelgriff aus Aluminium.
-  Válvula esfera paso total, después el medidor, tuerca de conexión directa al medidor mismo, con salida macho giratorio (360°), punto de medición de la presión y mariposa en aluminio.

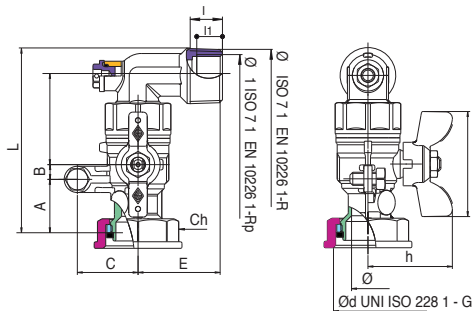





ØD x Ød	BOX	MASTER BOX	CODICE CODE	ØD1	ØP	I	I1	Ch	L	h	A	B	C	D	E	MOP	Kg
1" x 1 1/4"	-	25	9094290000	3/4"	20	19,1	16,3	46	117	52	32,5	9	37	58,5	50	5	0,70

Limiti di temperatura: -20°C +60°C - Temperature range: -20°C +60°C.



Art. 9494

-  Valvola a sfera passaggio totale, post-contatore, girello per collegamento diretto al contatore, con uscita M/F girevole (360°), con presa pressione di sicurezza, serratura di sicurezza.
-  Full bore ball valve, after the meter, nut for direct connection to the meter, (360°) rotating male outlet, with pressure measurement safety connection and safety lock.
-  Robinet boisseau sphérique à passage intégral, après-compteur, écrou pour connexion directe au compteur, avec sortie tournante male (360°), prise de pression de sécurité et serrure de sécurité.
-  Kugelhahn voller Durchgang, Montage nach dem Zähler, Überwurfmutter für direkte Verbindung mit dem Zähler, (360°) drehbarer Anschluss mit Außengewinde, Sicherheitsanschluss für Druckmessung mit Sicherheitsschloss.
-  Válvula esfera paso total, después el medidor, tuerca de conexión directa al medidor mismo, con salida macho giratorio (360°), punto de medición de la presión y cerradura de seguridad.

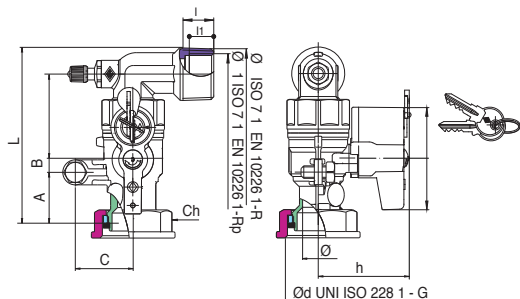





ØD x Ød	BOX	MASTER BOX	CODICE CODE	ØD1	ØP	I	I1	Ch	L	h	A	B	C	D	E	M	MOP	Kg
1" x 1 1/4"	-	25	9494290075	3/4"	20	19,1	16,3	46	117,5	61,5	32,5	9	37	58,5	50	71	5	0,83

Limiti di temperatura: -20°C +60°C - Temperature range: -20°C +60°C.



Art. 9F91



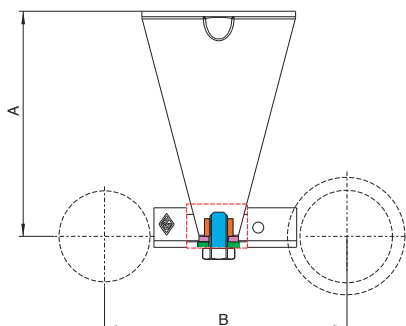

-  Traversa in acciaio interasse 110 mm, per collegamento valvola contatore e valvola post contatore.
-  Steel cross beam, center distance 110 mm, for assembly of valves before and after gas meter.
-  Traverse en acier interaxe 110 mm, pour la liaison des vannes avant et après compteur.
-  Stahlbalken, Achsenabstand 110 mm, für die Montage von Kugelhähne vor und nach dem Zähler.
-  Traversa en acero, distancia de 110 mm entre ejes, por conexión de la válvula antes y después el medidor.



MISURA SIZE	BOX	MASTER BOX	CODICE CODE	A
STANDARD	-	25	9F91000000	102,5







Art. 96U1

-  Cavetto di collegamento per presa pressione di sicurezza.
-  Connection pipe to the safety pressure measurement point.
-  Tube de connexion au point de mesure de la pression.
-  Verbindungsrohr zum Sicherheitsanschluss für Druckmessung.
-  Tubo de conexión con punto de seguridad de la presión.

MISURE	tutte-all
BOX	1
MASTER BOX	30
CODICE	96U1000000



Art. 96U2

-  Valvola presa pressione di sicurezza.
-  Safety valve for pressure measurement.
-  Robinet de sécurité our prise pression.
-  Sicherheitsventil für Druckmessung.
-  Válvula de seguridad para medicion de la presión.

MISURE	tutte - all
BOX	1
MASTER BOX	200
CODICE	96U2000000

serie **FIDO-SFER**

Art. **9080**



- Valvola a sfera per gas, filettatura femmina con portagomma e farfalla in alluminio.
- Ball valve for gas, female threaded and hose tail connection, with aluminium T-handle.
- Robinet à boisseau sphérique pour gaz, taraudée femelle, avec porte-tuyan en caoutchouc et poignée en aluminium.
- Kugelhahn für Gas, Innengewinde und Schlauchtülle, mit Aluminiumgriff.
- Válvula esfera por gas, rosca hembra/hembra con porta goma y mariposa de aluminio.

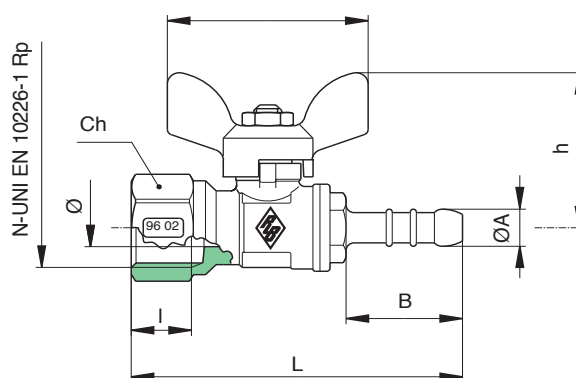
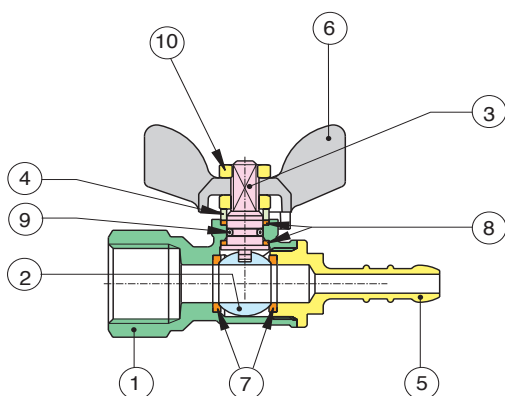

POS.	DENOMINAZIONE	PART NAME	DESCRIPTION	TEILBENENNUNG	DENOMINACION	MATERIALE-MATERIALS MATERIAUX-WERKSTOFF- MATERIAL	N°P
1	CORPO	BODY	CORPS	GEHÄUSE	CUERPO	OTTONE CW617N UNI EN 12465	1
2	SFERA	BALL	BILLE	KUGEL	ESFERA	OTTONE CW614N UNI EN 12464	1
3	ASTA	STEM	TIGE	SPINDEL	EJE	OTTONE CW614N UNI EN 12464	1
4	BUSSOLA PREMIGUARNIZIONE	PACKING GLAND	BAGUE DE PRESSE ETOUPE	VORSPANNRING	ANILLO PRENSAESTOPA	OTTONE CW614N UNI EN 12464	1
5	PORTAGOMMA	HOSE TAIL	PORTE CAOUTCHOUC	SCHLAUCHTÜLLE	PORTAGOMA	OTTONE CW617N UNI EN 12465	1
6	FARFALLA	T-HANDLE	POIGNÉE A PAPILLON	GRIFF	MARIPOSA	ALLUMINIO EN-AC 46100 EN 1706	1
7	GUARNIZIONE SFERA	BALL SEAT	JOINT DE TENUE BILLE	KUGELDICHTUNG	JUNTA ESFERA	P.T.F.E	2
8	GUARNIZIONE ASTA/ANTIATTRITO	STEM SEAL/THRUST WASHER	JOINT DE L'AXE/ANTIFRICTION	STOBHEMMENDE DICHTUNG	JUNTA EJE / ANTIFRICCIÓN	P.T.F.E	2
9	O-RING	O-RING	O-RING	O-RING	O-RING	NBR	1
10	DADO	NUT	ECROU	MUTTER	TUERCA	ACCIAIO CL 04	2





MISURA SIZE	DN	BOX	MASTER BOX	CODICE CODE	ØP	I	B	L	ØA	Ch	h	M	MOP	Kg
1/2" x 8*	15	50	100	9080870000	10	15	29	82,5	9,8	25	42	50	5	0,15
1/2" x 13*	15	50	100	9080900000	10	15	44	97,5	14	25	42	50	5	0,16

Limiti di temperatura: -20°C +60°C - Temperature range: -20°C +60°C.

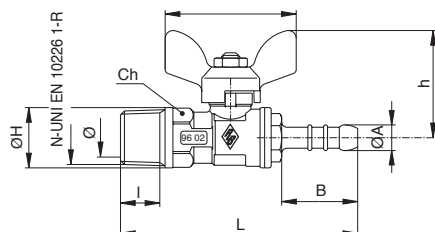
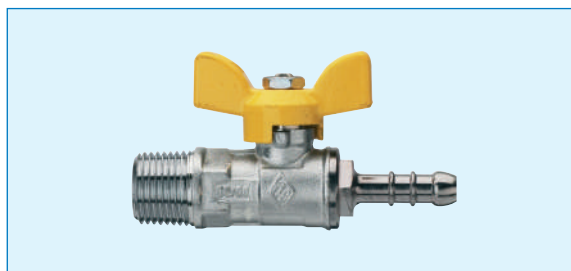
* Portagomma secondo norma UNI-CIG 7141-92 - Hose tail according to UNI-CIG 7141-92.

Art. 9081







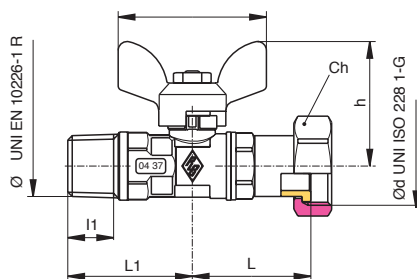

-  Valvola a sfera per gas, filettatura maschio con portagomma e farfalla in alluminio.
-  Ball valve for gas, male threaded and hose tail connection, with aluminium T-handle.
-  Robinet à boisseau sphérique pour gaz, taraudée mâle, avec porte-tuyan en caoutchouc et poignée en aluminium.
-  Kugelhahn für Gas, Außengewinde und Schlauchtülle, mit Aluminiumgriff.
-  Válvula esfera por gas, rosca macho con porta goma y mariposa de aluminio.

MISURA SIZE	DN	BOX	MASTER BOX	CODICE CODE	ØP	I	B	L	ØA	Ch	h	M	MOP	Kg
1/4" x 11	8	20	120	9081810000	7,5	11	22	79	10,8	20	42	50	5	0,14
3/8" x 8*	10	20	120	9081820000	10	11,5	29	86,5	9,8	20	42	50	5	0,15
3/8" x 13*	10	20	120	9081850000	10	11,5	44	101,5	14	20	42	50	5	0,16
1/2" x 8*	15	50	100	9081870000	10	15	29	90,5	9,8	20	42	50	5	0,15
1/2" x 13*	15	50	100	9081900000	10	15	44	105,5	14	20	42	50	5	0,17

Limiti di temperatura: -20°C +60°C - Temperature range: -20°C +60°C.
 *Portagomma secondo norma UNI-CIG 7141-92 - Hose tail according to UNI-CIG 7141-92.

Art. 9083







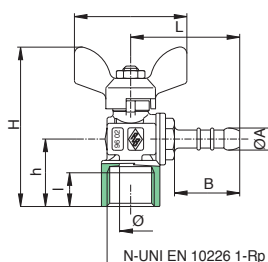

-  Valvola a sfera per gas, filettatura maschio, con girello, farfalla in alluminio.
-  Ball valve for gas, male thread, with ring nut, aluminium T-handle.
-  Robinet à boisseau sphérique pour gaz, taraudée male, avec écrou de raccord, papillon en aluminium.
-  Kugelhahn für gas, Aussengewinde, mit mutter, mit Aluminium Flügelgriff.
-  Válvula esfera por gas, rosca macho, con tuerca loca, mariposa en aluminio.

ØD x Ød	BOX	MASTER BOX	CODICE CODE	ØP	L	L1	I	Ch	h	M	ØH	MOP	Kg
1/2" x 1/2"	50	100	9083040000	10	34,75	42	8	24	38,5	50	23	5	0,20
1/2" x 3/4"	50	100	9083260000	10	40	42	8	30	38,5	50	23	5	0,24

Limiti di temperatura: -20°C +60°C - Temperature range: -20°C +60°C.

Art. 9084





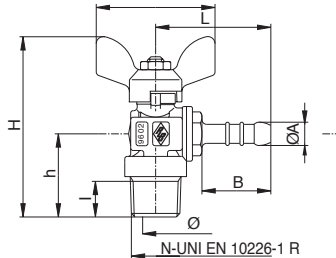

-  Valvola a sfera per gas a squadra, filettatura femmina con portagomma e farfalla in alluminio.
-  Angle ball valve for gas, female threaded and hose tail connection, with aluminium T-handle.
-  Robinet à boisseau sphérique pour gaz, à équerre, taraudée femelle, avec porte-tuyan en caoutchouc et poignée à papillon.
-  Eck-Kugelhahn für Gas, Innengewinde und Schlauchtülle, mit Aluminiumgriff.
-  Válvula esfera por gas escuadra, rosca hembra con porta goma y mariposa de aluminio.

MISURA SIZE	BOX	MASTER BOX	CODICE CODE	ØP	L	H	I	ØA	B	h	M	MOP	Kg
1/2" x 8*	50	100	9084870000	10	48,5	72	15	9,8	29	30	50	5	0,15
1/2" x 13*	50	100	9084900000	10	63,5	72	15	14	44	30	50	5	0,15

Limiti di temperatura: -20°C +60°C - Temperature range: -20°C +60°C.
 *Portagomma secondo norma UNI-CIG 7141-92 - Hose tail according to UNI-CIG 7141-92.



Art. 9085

-  Valvola a sfera per gas a squadra, filettatura maschio con portagomma e farfalla in alluminio.
-  Angle ball valve for gas, male threaded and hose tail connection, with aluminium T-handle.
-  Robinet à boisseau sphérique pour gaz, à équerre, taraudée mâle, avec porte-tuyau en caoutchouc et poignée à papillon.
-  Eck-Kugelhahn für Gas, Außengewinde und Schlauchtülle, mit Aluminiumgriff.
-  Válvula esfera por gas escuadra, rosca macho con porta goma y mariposa de aluminio.



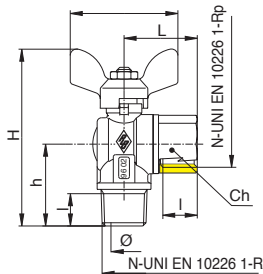

MISURA SIZE	DN	BOX	MASTER BOX	CODICE CODE	ØP	I	B	L	ØA	H	h	M	MOP	Kg
3/8" x 8"	10	20	120	9085820000	10	11,4	29	50	9,8	71,5	29,5	50	5	0,14
3/8" x 13"	10	20	120	9085850000	10	11,4	44	63,5	14	71,5	29,5	50	5	0,15
1/2" x 8"	15	50	100	9085870000	10	15	29	50	9,8	77	35	50	5	0,16
1/2" x 13"	15	50	100	9085900000	10	15	44	63,5	14	77	35	50	5	0,17

Limiti di temperatura: -20°C +60°C - Temperature range: -20°C +60°C.

* Portagomma secondo norma UNI-CIG 7141-92 - Hose tail according to UNI-CIG 7141-92.



Art. 9086



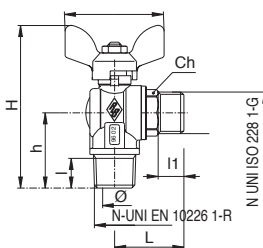

-  Valvola a sfera per gas a squadra, filettatura maschio con attacco femmina per tubo flessibile metallico UNI 9891 e farfalla in alluminio.
-  Angle ball valve for gas, male threaded and female connection for flexible metal hose acc. to UNI 9891 with aluminium T-handle.
-  Robinet à boisseau sphérique pour gaz, à équerre, taraudée mâle avec connexion femelle, pour tuyau flexible métallique UNI 9891 et poignée à papillon en aluminium.
-  Eck-Kugelhahn für Gas, Außengewinde und Gas-Rohranschluss nach UNI 9891 mit Aluminium Flügelgriff.
-  Válvula esfera por gas escuadra, rosca macho con conexión hembra por tubo flexible metálico UNI 9891 y mariposa de aluminio.

MISURA SIZE	DN	BOX	MASTER BOX	CODICE CODE	ØP	I	L	H	h	Ch	M	MOP	Kg
1/2" x 1/2"	15	50	100	9086250000	12,5	15	34	82	38	50	50	5	0,19

Limiti di temperatura: -20°C +60°C - Temperature range: -20°C +60°C.



Art. 9087





-  Valvola a sfera per gas a squadra, filettatura maschio con attacco maschio per tubo flessibile metallico UNI 9891 e farfalla in alluminio.
-  Angle ball valve for gas, male threaded and male connection for flexible metal hose acc. to UNI 9891 with aluminium T-handle.
-  Robinet à boisseau sphérique pour gaz, à équerre, taraudée mâle avec connexion mâle, pour tuyau flexible métallique UNI 9891 et poignée à papillon en aluminium.
-  Eck-Kugelhahn für Gas, Außengewinde und Gas-Rohranschluss nach UNI 9891 mit Aluminium Flügelgriff.
-  Válvula esfera por gas escuadra, rosca macho con conexión macho por tubo flexible metálico UNI 9891 y mariposa de aluminio.

MISURA SIZE	DN	BOX	MASTER BOX	CODICE CODE	ØP	I	I1	L	H	h	Ch	M	MOP	Kg
1/2" x 1/2"	15	50	100	9087250000	12,5	15	13	35	82	38	22	50	5	0,20

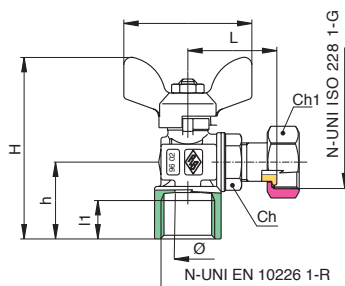
Limiti di temperatura: -20°C +60°C - Temperature range: -20°C +60°C.

Art. 9088





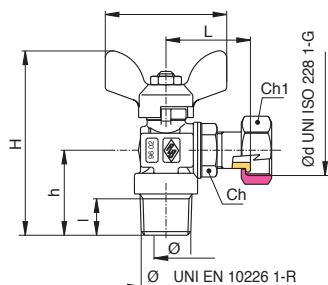

-  Valvola a sfera per gas a squadra, filettatura femmina con girello, farfalla in alluminio.
-  Angle ball valve for gas, female threaded and nut connection, with aluminium T-handle.
-  Robinet à boisseau sphérique pour gaz, à équerre, taraudée femelle avec écrou et poignée à papillon en aluminium.
-  Eck-Kugelhahn für Gas, Innengewinde und Verschraubung mit Aluminium Flügelgriff.
-  Válvula esfera por gas escuadra, rosca hembra con vancejo y mariposa de aluminio.

MISURA SIZE	DN	BOX	MASTER BOX	CODICE CODE	ØP	I	L	H	h	Ch	Ch1	M	MOP	Kg
1/2" x 1/2"	15	50	100	9088250000	10	15	35	82	30	20	24	50	5	0,18

Limiti di temperatura: -20°C +60°C - Temperature range: -20°C +60°C.



Art. 9089



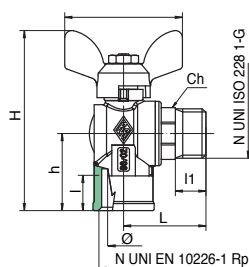

-  Valvola a sfera per gas a squadra, filettatura maschio con girello, farfalla in alluminio.
-  Angle ball valve for gas, male threaded and nut connection, with aluminium T-handle.
-  Robinet à boisseau sphérique pour gaz, à équerre, taraudée mâle avec écrou et poignée à papillon en aluminium.
-  Eck-Kugelhahn für Gas, Außengewinde und Verschraubung mit Aluminium Flügelgriff.
-  Válvula esfera por gas escuadra, rosca macho con vancejo y mariposa en aluminio.

ØD x Ød	DN	BOX	MASTER BOX	CODICE CODE	ØP	I	Ch	Ch1	H	L	h	M	MOP	Kg
1/2" x 1/2"	15	50	100	9089250000	10	17	20	24	75	35	35	50	5	0,18
1/2" x 3/4"	15	50	100	9089260000	10	17	20	30	75	35	35	50	5	0,21
3/4" x 3/4"	20	30	60	9089270000	15	19,5	27	30	84	45	38	50	5	0,32

Limiti di temperatura: -20°C +60°C - Temperature range: -20°C +60°C.



Art. 9090

-  Valvola a sfera per gas a squadra, filettatura femmina con attacco maschio per tubo flessibile metallico UNI 9891 e farfalla in alluminio.
-  Angle ball valve for gas, female threaded and male connection flexible metal hose acc. to UNI 9891 with aluminium T-handle.
-  Robinet à boisseau sphérique pour gaz à équerre, taraudée femelle avec connexion femelle pour tuyau flexible métallique UNI 9891 et papillon en aluminium.
-  Eck-Kugelhahn für Gas, Innengewinde und Gas-Rohranschluss nach UNI 9891 mit Aluminium Flügelgriff.
-  Válvula esfera escuadra por gas rosca hembra con conexión hembra por tubo flexible metálico UNI 9891 y mariposa en aluminio.

MISURA SIZE	DN	BOX	MASTER BOX	CODICE CODE	ØP	I	I1	L	H	h	Ch	M	MOP	Kg
1/2" x 1/2"	15	50	100	9090040000	15	15	13	35	76,5	32,8	22	50	5	0,20

Limiti di temperatura: -20°C +60°C - Temperature range: -20°C +60°C.

serie SICUR-BLOCK

Art. 9170



- Valvola a sfera per gas, filettatura F/F, farfalla in alluminio con scatto di sicurezza in chiusura.
- Ball valve for gas, F/F threaded, with security closing aluminium T-handle.
- Robinet à boisseau sphérique pour gaz, taraudée F/F, poignée à papillon en aluminium, fermeture avec declic de sécurité.
- Kugelhahn für Gas, beiderseits Innengewinde mit Sicherheits Aluminium Flügelgriff.
- Válvula esfera por gas, roscas hembra/hembra, mariposa de aluminio con arretrato de seguridad en cierre.

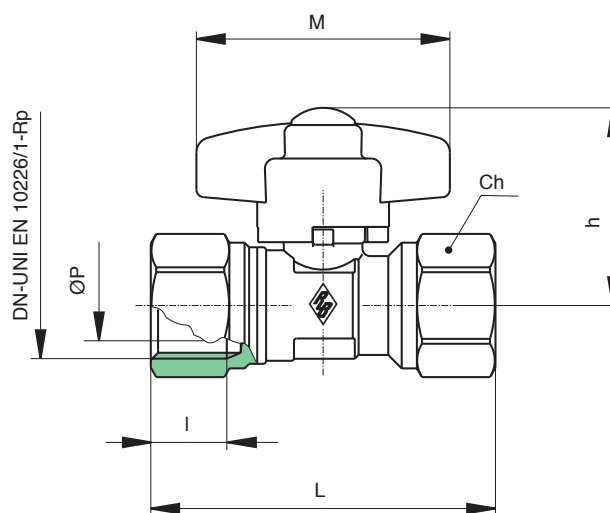
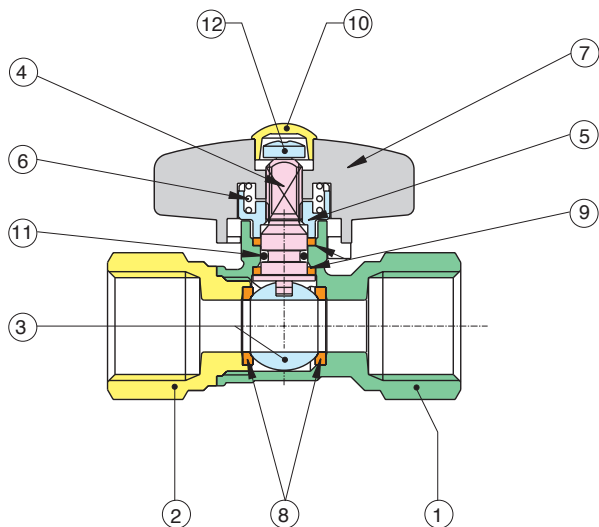





POS.	DENOMINAZIONE	PART NAME	DESCRIPTION	TEILBENENNUNG	DENOMINACION	MATERIALE-MATERIALS MATERIAUX-WERKSTOFF- MATERIAL	N°P
1	CORPO	BODY	CORPS	GEHÄUSE	CUERPO	OTTONE CW617N UNI EN 12165	1
2	MANICOTTO	END CONNECTION	MANCHON	MUFFE	MANGUITO	OTTONE CW617N UNI EN 12165	1
3	SFERA	BALL	BILLE	KUGEL	ESFERA	OTTONE CW614N UNI EN 12164	1
4	ASTA	STEM	TIGE	SPINDEL	EJE	OTTONE CW614N UNI EN 12164	1
5	GHIERA	STEM RETAINING NUT	EMBOUT	RING	ANILLO ROSCADO	OTTONE CW617N UNI EN 12165	1
6	MOLLA	SPRING	RESSORT	FEDER	RESORTE	ACCIAIO INOX AISI 302	1
7	FARFALLA	T-HANDLE	PIOGNÉE À PAPILLON	GRIFF	MARIPOSA	ALLUMINIO EN-AC 46100 EN 1706	1
8	GUARNIZIONE SFERA	BALL SEAT	JOINT DE TENUE BILLE	KUGELDICHTUNG	JUNTA ESFERA	P.T.F.E	2
9	GUARNIZIONE ANTIATTRITO	STEM SEAL/THRUST WASHER	JOINT DE L'AXE/ANTIFRICTION	STOBHEMME DICHTUNG	JUNTA EJE/ANTIFRICCIÓN	P.T.F.E	2
10	TAPPO	CAP	BOUCHON	PFROPFEN	TAPÓN	ABS	1
11	O-RING	O-RING	O-RING	O-RING	O-RING	NBR	1
12	VITE	SCREW	VIS	SCHRAUBE	TORNILLO	OTTONE CW614N UNI EN 12164	1

MISURA SIZE	DN	BOX	MASTER BOX	CODICE CODE	ØP	I	L	Ch	h	M	MOP	Kg
1/2"	15	15	90	9170040000	10	15	68	20	38,5	50	5	0,18

Limiti di temperatura: -20°C +60°C - Temperature range: -20°C +60°C.

Art. 9171



-  Valvola a sfera per gas, filettatura F/M, farfalla in alluminio con scatto di sicurezza in chiusura.
-  Ball valve for gas, F/M threaded, with security closing aluminium T-handle.
-  Robinet à boisseau sphérique pour gaz, taraudée F/M, poignée à papillon en aluimium, fermeture avec declic de sécurité.
-  Kugelhahn für Gas, IG/AG mit Sicherheits Aluminium Flügelgriff.
-  Válvula esfera por gas, roscas hembra/macho, mariposa de aluminio con arrebato de seguridad en cierre.

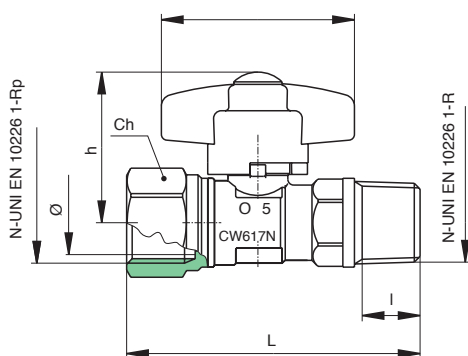





MISURA SIZE	DN	BOX	MASTER BOX	CODICE CODE	ØP	I	L	Ch	h	M	MOP	Kg
1/2"	15	15	90	9171040000	10	15	76	20	38,5	50	5	0,18

Limiti di temperatura: -20°C +60°C - Temperature range: -20°C +60°C.



Art. 9180

-  Valvola a sfera per gas, filettatura femmina, con portagomma, farfalla in alluminio con scatto di sicurezza in chiusura.
-  Ball valve for gas, female threaded and hose tail connection, with security closing aluminium T-handle.
-  Robinet à boisseau sphérique pour gaz, taraudée femelle, porte-tuyau en caoutchouc, poignée à papillon en aluminium, fermeture avec declic de sécurité.
-  Kugelhahn für Gas, Innengewinde und Schlauchtülle, mit Sicherheits Aluminium Flügelgriff.
-  Válvula esfera por gas, roscas hembra con porta goma, mariposa en aluminio con arrebato de seguridad en cierre.

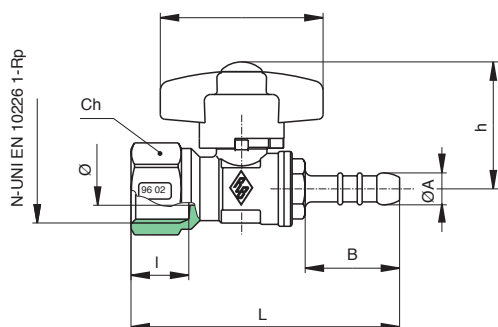



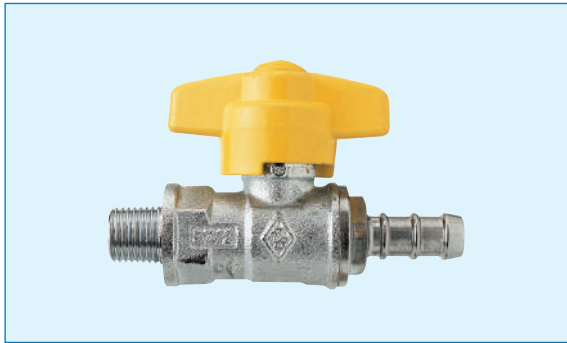

MISURA SIZE	DN	BOX	MASTER BOX	CODICE CODE	ØP	I	B	L	ØA	Ch	h	M	MOP	Kg
1/2" x 8"	15	15	90	9180870000	10	15	29	82,5	9,8	25	38,5	50	5	0,16
1/2" x 13"	15	15	90	9180900000	10	15	44	97,5	14	25	38,5	50	5	0,17

Limiti di temperatura: -20°C +60°C - Temperature range: -20°C +60°C.

* Portagomma secondo norma UNI-CIG 7141-92 - Hose tail according to UNI-CIG 7141-92.



Art. 9181

-  Valvola a sfera per gas, filettatura maschio, con portagomma, farfalla in alluminio con scatto di sicurezza in chiusura.
-  Ball valve for gas, male threaded and hose tail connection, with security closing aluminium T-handle.
-  Robinet à boisseau sphérique pour gaz, taraudée mâle, porte-tuyau en caoutchouc, poignée à papillon en aluminium, fermeture avec declic de sécurité.
-  Kugelhahn für Gas, Außengewinde und Schlauchtülle, mit Sicherheits Aluminium Flügelgriff.
-  Válvula esfera por gas, roscas macho con porta goma, mariposa en aluminio con arretrato de seguridad en cierre.

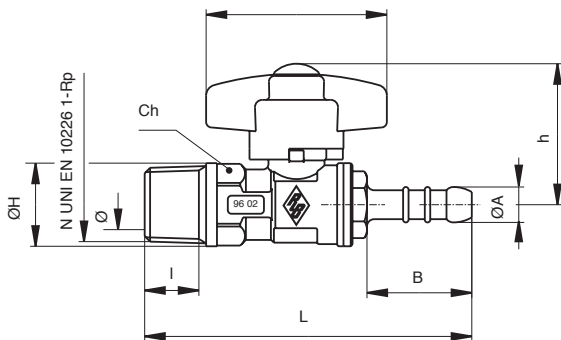





MISURA SIZE	DN	BOX	MASTER BOX	CODICE CODE	ØP	I	B	L	ØA	Ch	h	M	ØH	MOP	Kg
1/4" x 11	8	25	50	9181810000	10	11	22	79	10,8	20	38,5	50	23	5	0,16
3/8" x 8*	10	25	50	9181820000	10	11,5	29	86,5	9,8	20	38,5	50	23	5	0,16
3/8" x 13*	10	25	50	9181850000	10	11,5	44	101,5	14	20	38,5	50	23	5	0,17
1/2" x 8*	15	15	90	9181870000	10	15	29	90,5	9,8	20	38,5	50	23	5	0,16
1/2" x 13*	15	15	90	9181900000	10	15	44	105,5	14	20	38,5	50	23	5	0,18

Limiti di temperatura: -20°C +60°C - Temperature range: -20°C +60°C.
 * Portagomma secondo norma UNI-CIG 7141-92 - Hose tail according to UNI-CIG 7141-92.



Art. 9183

-  Valvola a sfera per gas, filettatura maschio, con girello, farfalla in alluminio con scatto di sicurezza.
-  Ball valve for gas, male thread, with ring nut, aluminium T-handle with security lock.
-  Robinet à boisseau sphérique pour gaz, taraudée male, avec écrou de raccord, papillon en aluminium avec declic de sécurité.
-  Kugelhahn für GAS, Aussengewinde, mit mutter, mit Aluminium Sicherheitsflügelgriff.
-  Válvula esfera por gas, rosca macho, con tuerca loca, mariposa en aluminio con sistema de seguridad.

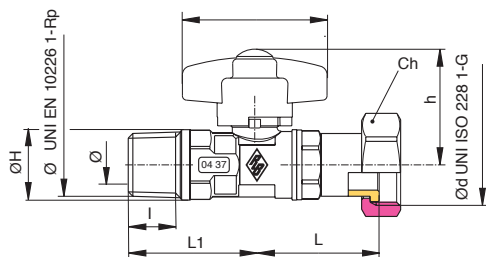





ØD x Ød	BOX	MASTER BOX	CODICE CODE	ØP	L	L1	I	Ch	h	M	ØH	MOP	Kg
1/2" x 1/2"	50	100	9183040000	10	76,5	42	15	24	38,5	50	23	5	0,20
1/2" x 3/4"	50	100	9183260000	10	82	42	15	30	38,5	50	23	5	0,24

Limiti di temperatura: -20°C +60°C - Temperature range: -20°C +60°C.

Art. 9184



-  Valvola a sfera per gas a squadra, filettatura femmina, con portagomma, farfalla in alluminio con scatto di sicurezza in chiusura.
-  Angle ball valve for gas, female threaded and hose tail connection, with security closing aluminium T-handle.
-  Robinet à boisseau sphérique pour gaz à équerre, taraudée femelle, porte-tuyau en caoutchouc, poignée à papillon en aluminium, fermeture avec déclic de sécurité.
-  Eck-Kugelhahn für Gas, Innengewinde und Schlauchtülle, mit Sicherheits Aluminium Flügelgriff.
-  Válvula esfera por gas escuadra, rosca hembra con porta goma, mariposa en aluminio con arrebato de seguridad en cierre.

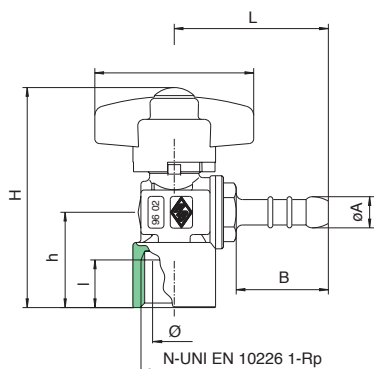





MISURA SIZE	DN	BOX	MASTER BOX	CODICE CODE	ØP	I	B	H	L	ØA	h	M	MOP	Kg
1/2" x 8*	15	15	90	9184870000	10	15	29	68,5	48,5	9,8	30	50	5	0,16
1/2" x 13*	15	15	90	9184900000	10	15	44	68,5	63,5	14	30	50	5	0,18

Limiti di temperatura: -20°C +60°C - Temperature range: -20°C +60°C.

* Portagomma secondo norma UNI-CIG 7141-92 - Hose tail according to UNI-CIG 7141-92.



Art. 9185

-  Valvola a sfera per gas a squadra, filettatura maschio, con portagomma, farfalla in alluminio con scatto di sicurezza in chiusura.
-  Angle ball valve for gas, male threaded and hose tail connection, with security closing aluminium T-handle.
-  Robinet à boisseau sphérique pour gaz à équerre, taraudée mâle, porte-tuyau en caoutchouc, poignée à papillon en aluminium, fermeture avec déclic de sécurité.
-  Eck-Kugelhahn für Gas, Außengewinde und Schlauchtülle mit Sicherheits Aluminium Flügelgriff.
-  Válvula esfera por gas escuadra, rosca macho con porta goma, mariposa en aluminio con arrebato de seguridad en cierre.

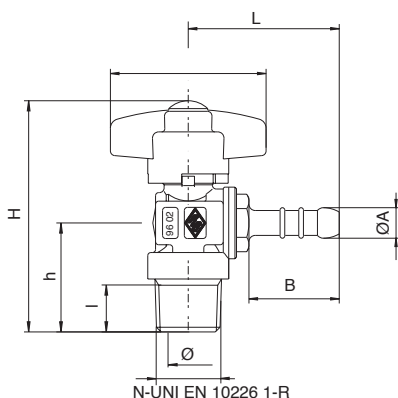





MISURA SIZE	DN	BOX	MASTER BOX	CODICE CODE	ØP	I	B	L	ØA	H	h	M	MOP	Kg
3/8" x 8*	10	25	50	9185820000	10	11,5	29	48,5	9,8	68	29,5	50	5	0,16
3/8" x 13*	10	25	50	9185850000	10	11,5	44	63,4	14	68	29,5	50	5	0,17
1/2" x 8*	15	15	30	9185870000	10	15	29	48,5	9,8	73,5	35	50	5	0,17
1/2" x 13*	15	15	30	9185900000	10	15	44	63,5	14	73,5	35	50	5	0,19

Limiti di temperatura: -20°C +60°C - Temperature range: -20°C +60°C.

* Portagomma secondo norma UNI-CIG 7141-92 - Hose tail according to UNI-CIG 7141-92.



Art. 9186

-  Valvola a sfera per gas a squadra, filettatura maschio, con attacco femmina per tubo flessibile metallico UNI 9891, farfalla in alluminio con scatto di sicurezza in chiusura.
-  Angle ball valve for gas, male threaded and flexible metal hose female connection acc. to UNI 9891, with security closing aluminium T-handle.
-  Robinet à boisseau sphérique pour gaz à équerre, taraudée mâle, avec connexion femelle pour tuyau flexible métallique UNI 9891, poignée à papillon en aluminium, fermeture avec dé clic de sécurité.
-  Eck-Kugelhahn für Gas, Außengewinde und Innengewindeanschluss für Gas-Rohr nach UNI 9891, mit Sicherheits Aluminium Flügelgriff.
-  Válvula esfera por gas escuadra, rosca macho con conexión hembra por tubo metálico UNI 9891, mariposa en aluminio con arrebato de seguridad en cierre.

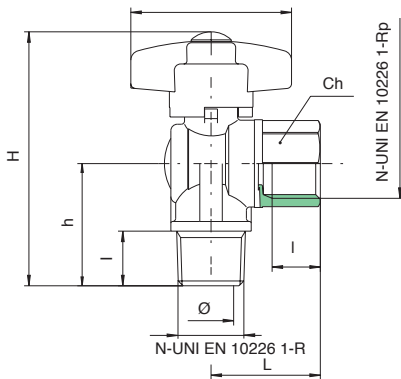





MISURA SIZE	DN	BOX	MASTER BOX	CODICE CODE	ØP	I	H	L	Ch	h	M	MOP	Kg
1/2" x 1/2"	15	50	100	9186250000	12,5	15	73,5	34	25	35	50	5	0,21

Limiti di temperatura: -20°C +90°C - Temperature range: -20°C +90°C.



Art. 9187

-  Valvola a sfera per gas a squadra, filettatura maschio, con attacco maschio per tubo flessibile metallico UNI 9891, farfalla in alluminio con scatto di sicurezza in chiusura.
-  Angle ball valve for gas, male threaded and flexible metal hose male connection acc. to UNI 9891, with security closing aluminium T-handle.
-  Robinet à boisseau sphérique pour gaz à équerre, taraudée mâle, avec connexion mâle pour tuyau flexible métallique UNI 9891, poignée à papillon en aluminium, fermeture avec dé clic de sécurité.
-  Eck-Kugelhahn für Gas, Außengewinde und Außengewindeanschluss für Gas-Rohr nach UNI 9891, mit Sicherheits Aluminium Flügelgriff.
-  Válvula esfera por gas escuadra, rosca macho con conexión macho por tubo metálico UNI 9891, mariposa en aluminio con arrebato de seguridad en cierre.

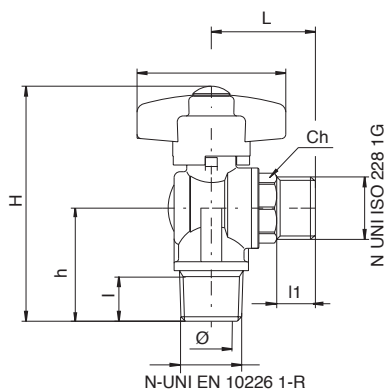





MISURA SIZE	DN	BOX	MASTER BOX	CODICE CODE	ØP	I	I1	L	H	h	M	Ch	MOP	Kg
1/2" x 1/2"	15	50	100	9187250000	12,5	15	13	35	78,5	38	50	55	5	0,21

Limiti di temperatura: -20°C +90°C - Temperature range: -20°C +90°C.

Art. 9188



-  Valvola a sfera per gas a squadra, filettatura femmina, con girello, farfalla in alluminio con scatto di sicurezza in chiusura.
-  Angle ball valve for gas, female threaded and ring nut connection, with security closing aluminium T-handle.
-  Robinet à boisseau sphérique pour gaz à équerre, taraudée femelle, avec écrou de raccord, poignée à papillon en aluminium, fermeture avec déclic de sécurité.
-  Eck-Kugelhahn für Gas, Innengewinde und Verschraubung mit Sicherheits Aluminium Flügelgriff.
-  Válvula esfera por gas escuadra, rosca hembra con vencejo, mariposa en aluminio y arebato de seguridad en cierre.

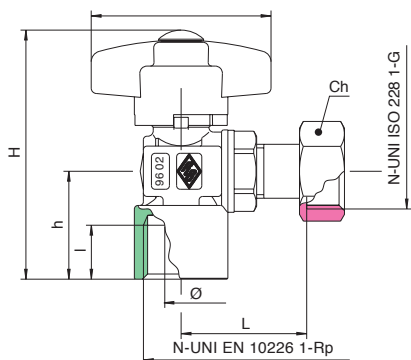





MISURA SIZE	DN	BOX	MASTER BOX	CODICE CODE	ØP	I	L	Ch	H	h	M	MOP	Kg
1/2" x 1/2"	15	50	100	9188250000	10	15	35	24	68,5	30	50	5	0,19

Limiti di temperatura: -20°C +90°C - Temperature range: -20°C +90°C.



Art. 9189

-  Valvola a sfera per gas a squadra, filettatura maschio, con girello, farfalla in alluminio con scatto di sicurezza in chiusura.
-  Angle ball valve for gas, male threaded and ring nut connection, with security closing aluminium T-handle.
-  Robinet à boisseau sphérique pour gaz à équerre, taraudée mâle, avec écrou de raccord, poignée à papillon en aluminium, fermeture avec déclic de sécurité.
-  Eck-Kugelhahn für Gas, Außengewinde und Verschraubung mit Sicherheits Aluminium Flügelgriff.
-  Válvula esfera por gas escuadra, rosca macho con vencejo, mariposa en aluminio y arebato de seguridad en cierre.

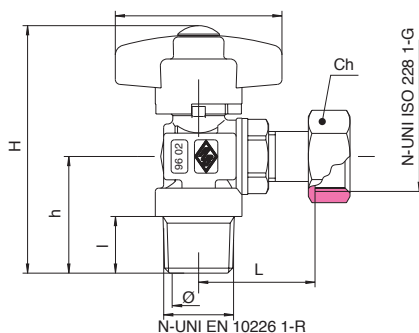

MISURA SIZE	DN	BOX	MASTER BOX	CODICE CODE	ØP	I	L	Ch	H	h	M	MOP	Kg
1/2" x 1/2"	15	50	100	9189250000	10	15	35	24	73,5	35	50	5	0,20

Limiti di temperatura: -20°C +90°C - Temperature range: -20°C +90°C.

serie FIDO-CASA

Art. 9390

**BREVETTATO
PATENTED**

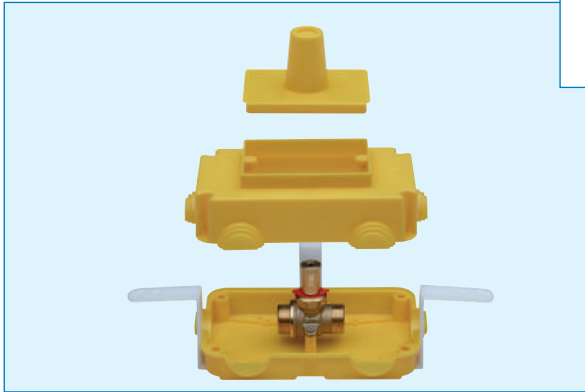

- Valvola a sfera gas con scatola ispezionabile da incasso a norma UNI 7129, attacchi eurocono.
- Built-in full bore ball valve for gas, copper connections and inspection box acc. to UNI 7129 specifications with euroconus seats.
- Robinet à boisseau a sphérique pour gaz pour boîte d'inspection à encastrer selon norme UNI 7129, connexions euroconiques.
- Unterflurkugelhahn für Gas, lötanschluss und Inspektionsschachtel nach UNI 7129 Norm, mit Eurokonus Sitz.
- Válvula esfera por gas con caja inspeccionable a embutir según norma UNI 7129, conexiones eurocono.

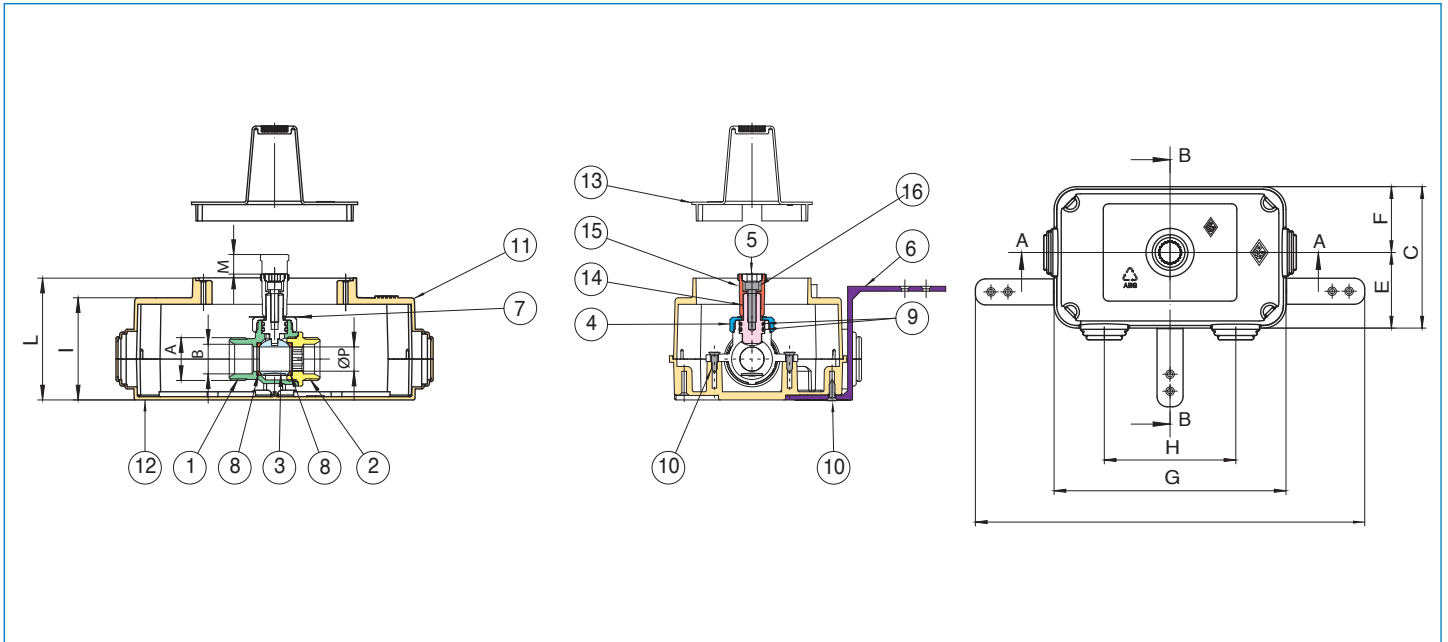

POS.	DENOMINAZIONE	PART NAME	DESCRIPTION	TEILBENENNUNG	DENOMINACION	MATERIALE-MATERIALS MATERIAUX-WERKSTOFF- MATERIAL	N°P
1	CORPO	BODY	CORPS	GEHÄUSE	CUERPO	OTTONE CW617N UNI EN 12165	1
2	MANICOTTO	END CONNECTION	MANCHON	MUFFE	MANGUITO	OTTONE CW614N UNI EN 12164	1
3	SFERA	BALL	BILLE	KUGEL	ESFERA	OTTONE CW617N UNI EN 12165	1
4	GHIERA	STEM RETAINING NUT	RACCORD	RING	ANILLO ROSCADO	OTTONE CW614N UNI EN 12164	1
5	GHIERA	STEM RETAINING NUT	RACCORD	RING	ANILLO ROSCADO	OTTONE CW614N UNI EN 12164	1
6	ZANCA	SUPPORT	SUPPORT	LAGER	SOPORTE	POM	3
7	PIASTRA	PLATE	PLAQUE	PLATTE	PLATE	PA6	1
8	GUARNIZIONE SFERA	BALL SEAT	JOINT DE TENUE BILLE	KUGRLDICHTUNG	JUNTA ESFERA	P.T.F.E	2
9	O-RING	O-RING	O-RING	O-RING	O-RING	NBR	2
10	VITE	SCREW	VIS	SCHRAUBE	TORNILLO	ACCIAIO	5
11	SCATOLA ISPEZIONABILE	INSPECTION BOX	BOLTE D'INSPECTION	INSPEKTIONSSCHACHTEL	CAJA INSPECCIONABLE	HIPS	1
12	SCATOLA ISPEZIONABILE	INSPECTION BOX	BOLTE D'INSPECTION	INSPEKTIONSSCHACHTEL	CAJA INSPECCIONABLE	HIPS	1
13	CARTER	COVER	CARTER	ABDECKUNG	CHARTER	ABS	1
14	ASTA	STEM	TIGE	SPINDEL	EJE	OTTONE CW614N UNI EN 12164	1
15	PROLUNGA	EXTENSION	VERLÄNGERUNG	ALLONGE	EXTENSIÓN	OTTONE CW614N UNI EN 12164	1
16	VITE	SCREW	VIS	SCHRAUBE	TORNILLO	ACCIAIO	1

MISURA SIZE	DN	BOX	MASTER BOX	CODICE CODE	ØP	C	D	E	F	G	H	I	L	M*	Kg
3/4 x Ø18	15	1	6	9390040000	15	109	299	58	51	178	101	62,5	74,5	10	0,46

* Estensione totale 30mm: M + art. 9394 - * Total extension 30 mm: M + art.9394.



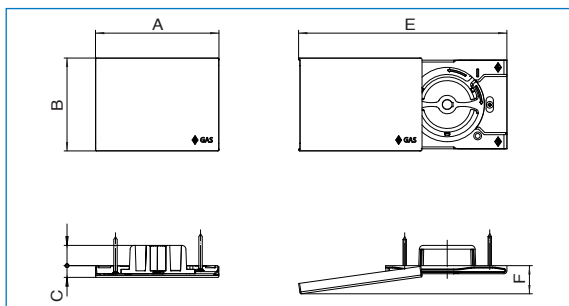

- Raccordi abbinabili:**
 • artt. 535100 e 535800 a pag. 337 e art. 9365 a pag. 191.
 • art. 9368, adattatore che trasforma eurocono in sede piana, a pag. 191, abbinabile a raccordi artt. 9360-9361-531700-535000, a pag. 190-191-335-337.

- Matching fittings:**
 • artt. 535100 and 535800 at page 337 and art. 9365 at page 191.
 • art. 9368, adapter to covert eurocone into flat seat, at page 191 suitable for fittings 9360-9361-531700-535000, at pages 190-191-335-337.



Art. 9394

BREVETTATO - PATENTED



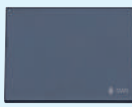
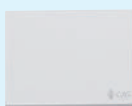
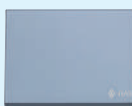

-  Organo di comando a scomparsa con placca a scorrimento per valvole artt. 9390/9398.
-  Control's conceable organ with sliding plate for valves artt. 9390/9398.
-  Organe de commande à disparition avec plaque à glissement pour vannes artt. 9390/9398.
-  Steuerung mit versenkbarer Schiebepplatte für Kugelhähne Artt. 9390/9398.
-  Órgano de control ocultable con placa corrediza por válvulas artt. 9390/9398.

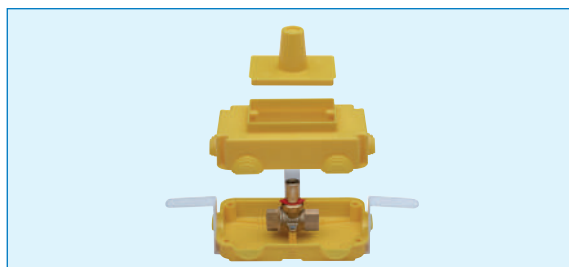
Dimensioni scatola vedi art.9390 - Inspections box dimension see art. 9390.

	MATERIALE MATERIALS	MISURA SIZE	BOX	MASTER BOX	CODICE CODE	A	B	C	D	E	F	Kg
	PLASTICA CROMATA CROMED PLASTIC	12,6 x 9,5	6	24	9394000000	126	95	12	21	210	30	0,12
	PLASTICA NERA BLACK PLASTIC	12,6 x 9,5	6	24	9394000001							
	PLASTICA BIANCA WHITE PLASTIC	12,6 x 9,5	6	24	9394000002							
	PLASTICA GRIGIA GREY PLASTIC	12,6 x 9,5	6	24	9394000003							



Art. 9398

-  Valvola a sfera gas con scatola ispezionabile da incasso a norma UNI 7129, attacchi F/F.
-  Built-in full bore ball valve for gas, copper connections and inspection box acc. to UNI 7129 specifications, with F/F connections.
-  Robinet à boisseau à sphérique pour gaz pour boîte d'inspection à encastrer selon norme UNI 7129, connexions F/F.
-  Unterflurkugelhahn für Gas, lötanschluss und Inspektionsschachtel nach UNI 7129 Norm, mit Innengewinde.
-  Válvula esfera por gas con caja inspeccionable a embutir según norma UNI 7129, conexiones hembra/hembra.

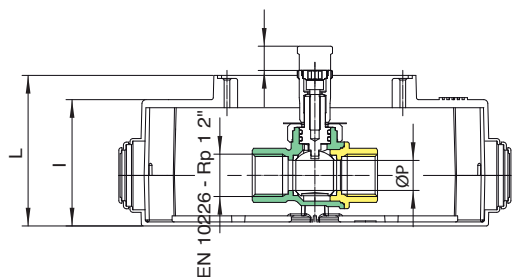

MISURA SIZE	DN	BOX	MASTER BOX	CODICE CODE	ØP	I	L	M*	Kg
1/2"	15	1	6	9398040000	15	62,5	74,5	10	0,47





* Estensione totale 30mm: M + art. 9394 - * Total extension 30mm: M + art.9394.

serie FIDO-CASA

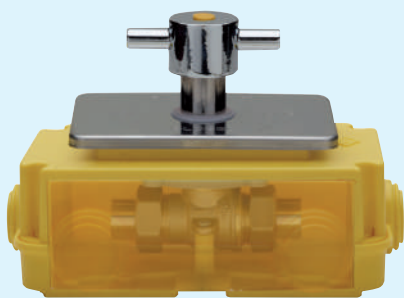
Art. 9380

**BREVETTATO
PATENTED**



-  Valvola a sfera gas con scatola ispezionabile da incasso a norma UNI 7129, attacchi tubo rame, organo di comando maniglia.
-  Gas ball valve with built-in inspection box according to UNI 7129 norms, copper pipe connections and control lever.
-  Robinet à boisseau sphérique gaz avec boîte d'inspection à encastrer selon norme UNI 7129, connexions tube cuivre et poignée de contrôle.
-  Gas Kugelhahn mit Einbau-Inspektionsschachtel nach Norm UNI 7129, Kupferrohr Anschluß und Bedienhandgriff.
-  Válvulas esfera gas con caja inspeccionable a empotrar según norma UNI 7129, conexiones por tubo cobre y palanca de control.

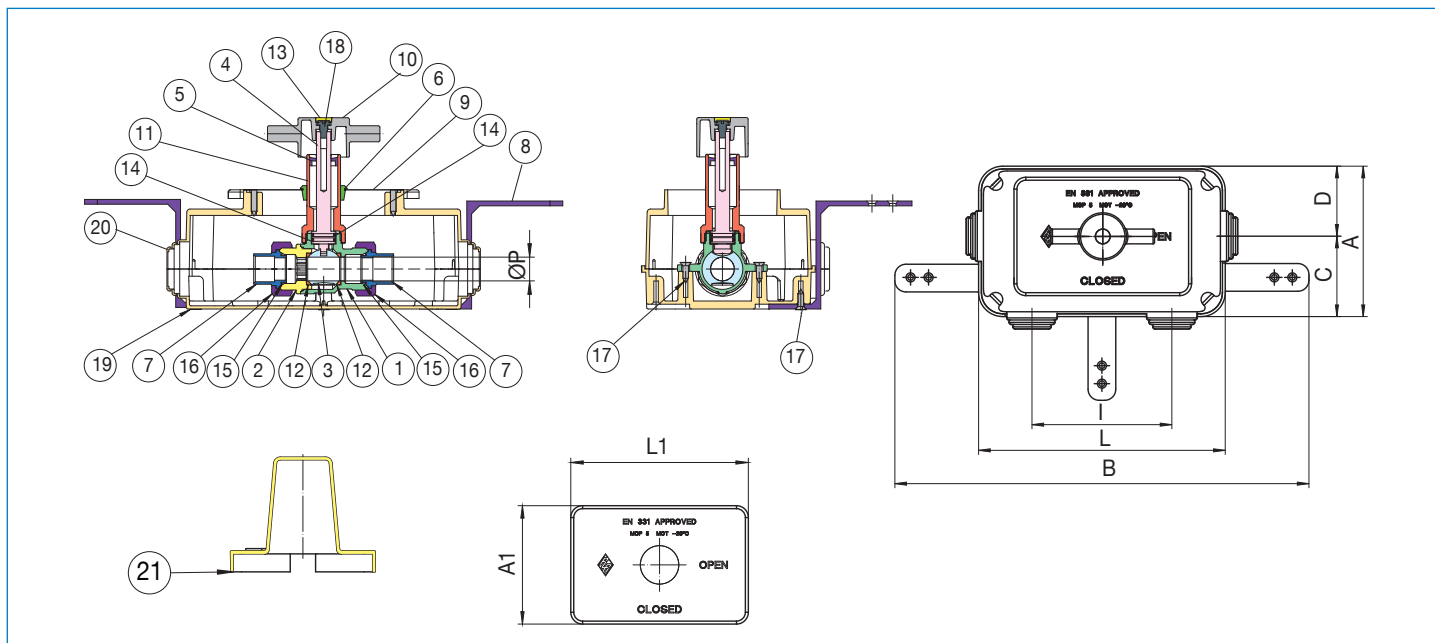

POS.	DENOMINAZIONE	PART NAME	DESCRIPTION	TEILBENENNUNG	DENOMINACION	MATERIALE-MATERIALS MATERIAUX-WERKSTOFF- MATERIAL	N°P
1	CORPO	BODY	CORPS	GEHÄUSE	CUERPO	OTTONE CW617N UNI EN 12165	1
2	MANICOTTO	END CONNECTION	MANCHON	MUFFE	MANGUITO	OTTONE CW614N UNI EN 12164	1
3	SFERA	BALL	BILLE	KUGEL	ESFERA	OTTONE CW617N UNI EN 12165	1
4	ASTA	STEM	TIGE	SPINDEL	EJE	OTTONE CW614N UNI EN 12164	1
5	GHIERA	STEM RETAINING NUT	RACCORD	RING	ANILLO ROSCADO	OTTONE CW614N UNI EN 12164	1
6	GUARNIZIONE COPERCHIO	LID SEAL	JOINT DE COUVERCLE	DECKELDICHUNG	ASIENTO TAPA	HDPE	1
7	RACCORDO	FITTING	RACCORD	KUPPLUNG	CONEXION	ZAMAG Zn Al4 ALLOY	2
8	ZANCA	SUPPORT	SUPPORT	LAGER	SOPORTE	POM	3
9	PIASTRA	PLATE	PLAQUE	PLATTE	PLATE	ACCIAIO INOX AISI 430	1
10	FARFALLA	T-HANDLE	PIOGNEE A PAPILLON	GRIFF	MARIPOSA	ZAMA	1
11	SUPPORTO	SUPPORT	SUPPORT	LAGER	SOPORTE	OTTONE CW614N UNI EN 12164	1
12	GUARNIZIONE SFERA	BALL SEAT	JOINT DE TENUE BILLE	KUGRLDICHUNG	JUNTA ESFERA	P.T.F.E	2
13	TAPPO	CAP	BOUCHON	KAPPE	TAPÓN	ABS	1
14	O-RING	O-RING	O-RING	O-RING	O-RING	NBR	2
15	O-RING	O-RING	O-RING	O-RING	O-RING	HNBR	2
16	DADO	NUT	ECROU	MUTTER	TUERCA	OTTONE CW617N UNI EN 12165	2
17	VITE	SCREW	VIS	SCHRAUBE	TORNILLO	ACCIAIO	5
18	VITE	SCREW	VIS	SCHRAUBE	TORNILLO	OTTONE CW614N UNI EN 12164	1
19	SCATOLA ISPEZ.	INSPECTION BOX	BOLTE D'INSPECTION	INSPEKTIONSSCHACHTEL	CAJA INSPECCIONABLE	HIPS	1
20	SCATOLA ISPEZ.	INSPECTION BOX	BOLTE D'INSPECTION	INSPEKTIONSSCHACHTEL	CAJA INSPECCIONABLE	HIPS	1
21	CARTER	COVER	CARTER	ABDECKUNG	CHARTER	ABS	1

Disponibile accessorio, art. 6111, a pag. 267 - The accessory, item 6111, is available. See at page 267.

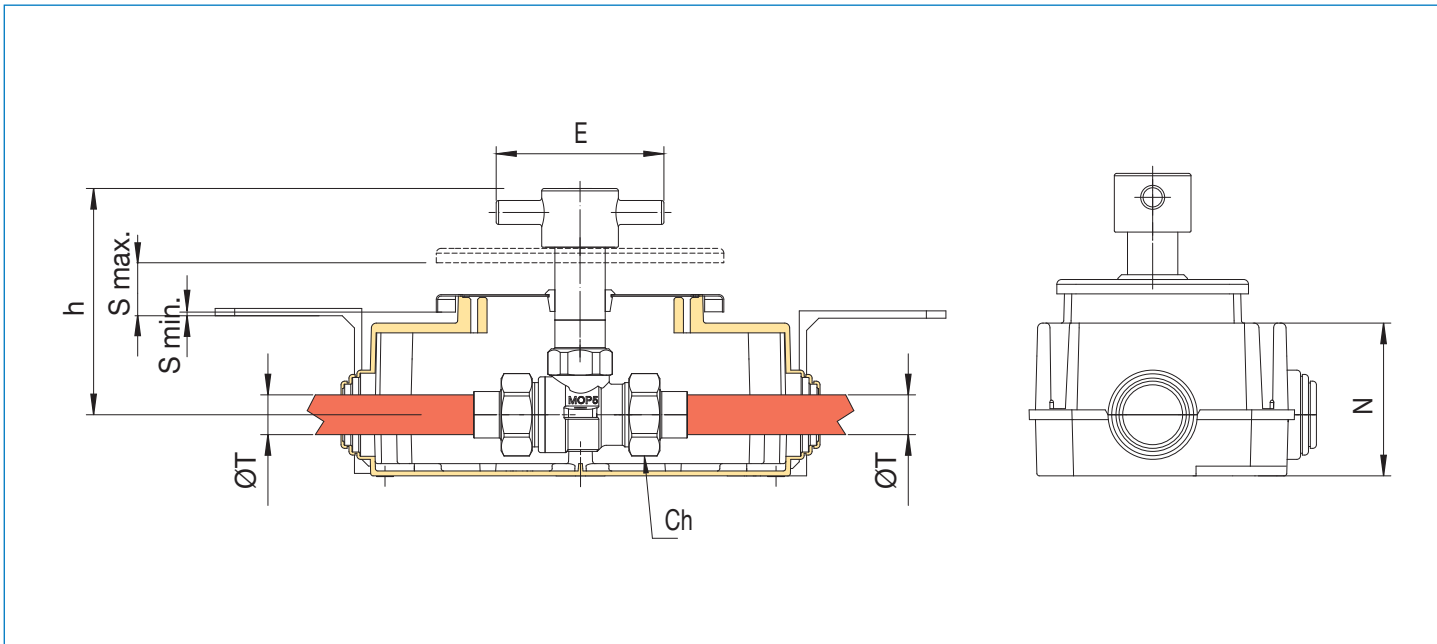

MISURA SIZE	BOX	MASTER BOX	CODICE CODE	ØP	ØT	A	A1	B	C	D	E	h	I	Ch	L	L1	N	S		Kg
																		min	max	
12	1	4	9380120000	15	12	109	80	299	58	51	70	94,5	101	30	178	120	62,5	1,5	20,5	0,78
14			9380140000	15	14	109	80	299	58	51	70	94,5	101	30	178	120	62,5	1,5	20,5	0,80
16			9380160000	15	16	109	80	299	58	51	70	94,5	101	30	178	120	62,5	1,5	20,5	0,77
18			9380180000	15	18	109	80	299	58	51	70	94,5	101	30	178	120	62,5	1,5	20,5	0,76
22			9380220000	15	22	109	80	299	58	51	70	94,5	101	30	178	120	62,5	1,5	20,5	0,84

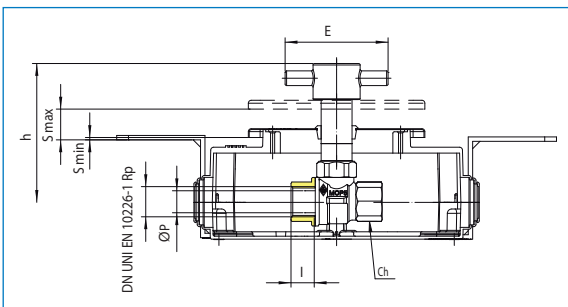

Art. 9388



Valvola a sfera gas con scatola ispezionabile da incasso a norma UNI 7129, attacchi F/F, organo di comando maniglia.



Gas ball valve with built-in inspection box according to UNI 7129 norms, F/F connections and control lever.



Robinet à boisseau sphérique gaz avec boîte d'inspection à encastrer selon norme UNI 7129, connexions F/F et poignée de contrôle.



Gas Kugelhahn mit Einbau-Inspektionsschachtel nach Norm UNI 7129, Innengewinde-Anschluß und Bedienhandgriff.



Válvulas esfera gas con caja inspeccionable a empotrar según norma UNI 7129, conexiones hembra/hembra y palanca de control.

Dimensioni scatola vedi art.9380 - Inspections box dimension see art. 9380.

MISURA SIZE	BOX	MASTER BOX	CODICE CODE	ØP	A	A1	B	C	D	E	h	I	Ch	L	L1	N	S		Kg
																	min	max	
1/2"	1	4	9388040000	15	109	80	299	58	51	70	94,5	101	30	178	120	62,5	1,5	20,5	0,67





Disponibile accessorio, art. 6111, a pag. 267 - The accessory, item 6111, is available. See at page 267.

serie FIDO-CASA

Art. 9370

**BREVETTATO
PATENTED**





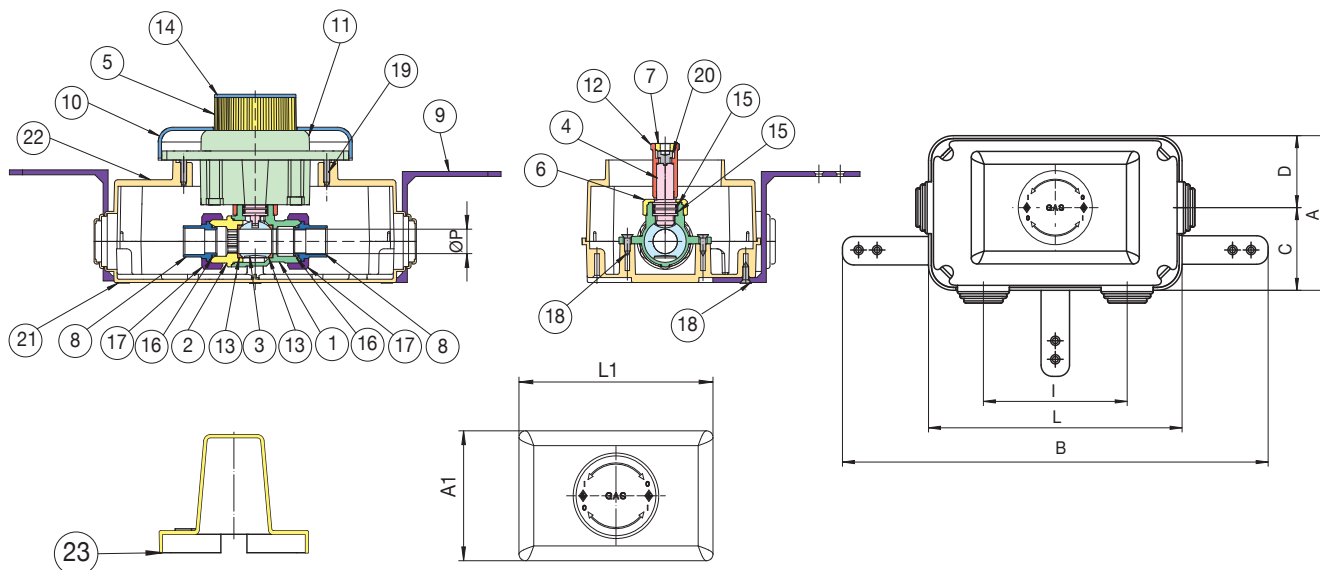

-  Valvola a sfera gas con scatola ispezionabile da incasso a norma UNI 7129, attacchi tubo rame, organo di comando premi e gira a scomparsa.
-  Built-in full bore ball valve for gas, copper connections and inspection box acc. to UNI 7129 specifications, with "push and turn" control knob.
-  Robinet à boisseau à sphérique pour gaz pour boîte d'inspection à encastrer selon norme UNI 7129, connexion pour tube en cuivre, avec commande de contrôle encastré "presse et tourne".
-  Unterflurkugelhahn für Gas, lötlanschluss und Inspektionsschachtel nach UNI 7129 Norm, mit Sicherheitshebel mit "pressen und drehen" Bedienknopf.
-  Válvula esfera por gas con caja inspeccionable a embutir según norma UNI 7129, conexión tubo de cobre, con pernilla de control "pulsar y girar".

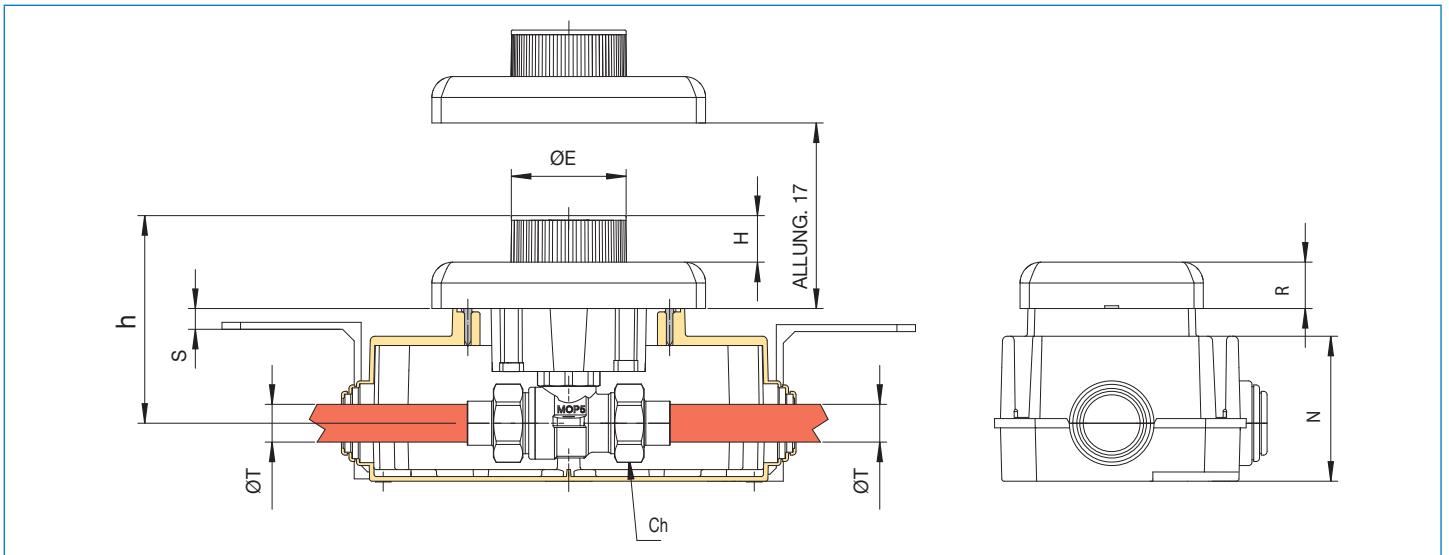

POS.	DENOMINAZIONE	PART NAME	DESCRIPTION	TEILBENENNUNG	DENOMINACION	MATERIALE-MATERIALS MATERIAUX-WERKSTOFF- MATERIAL	N°P
1	CORPO	BODY	CORPS	GEHÄUSE	CUERPO	OTTONE CW617N UNI EN 12165	1
2	MANICOTTO	END CONNECTION	MANCHON	MUFFE	MANGUITO	OTTONE CW614N UNI EN 12164	1
3	SFERA	BALL	BILLE	KUGEL	ESFERA	OTTONE CW617N UNI EN 12165	1
4	ASTA	STEM	TIGE	SPINDEL	EJE	OTTONE CW614N UNI EN 12164	1
5	GHIERA	STEM RETAINING NUT	RACCORD	RING	ANILLO ROSCADO	ABS	1
6	GHIERA	STEM RETAINING NUT	RACCORD	RING	ANILLO ROSCADO	OTTONE CW614N UNI EN 12164	1
7	GHIERA	STEM RETAINING NUT	RACCORD	RING	ANILLO ROSCADO	OTTONE CW614N UNI EN 12164	1
8	RACCORDO	FITTING	RACCORD	VERBINDUNGSSTÜK	CONEXIÓN	BRONZO G Cu Sn5 Zn5 Pb5	2
9	ZANCA	SUPPORT	SUPPORT	LAGER	SOPORTE	POM	3
10	PIASTRA	PLATE	PLAQUE	PLATTE	PLATE	ABS	1
11	MECCANISMO DI MANOVRA	OPERATING MECHANISM	MECANISME DE MANOEUVRE	BEDIENUNGSSYSTEM	MECANISMO DE MANIOBRA	POM	1
12	PROLUNGA	EXTENSION	VERLÄNGERUNG	ALLONGE	EXTENSIÓN	OTTONE CW614N UNI EN 12164	1
13	GUARNIZIONE SFERA	BALL SEAT	JOINT DE TENUE BILLE	KUGRDLICHTUNG	JUNTA ESFERA	P.T.F.E	2
14	TAPPO	CAP	BOUCHON	KAPPE	TAPÓN	ABS	1
15	O-RING	O-RING	O-RING	O-RING	O-RING	NBR	2
16	O-RING	O-RING	O-RING	O-RING	O-RING	HNBR	2
17	DADO	NUT	ECROU	MUTTER	TUERCA	OTTONE CW617N UNI EN 12165	2
18	VITE	SCREW	VIS	SCHRAUBE	TORNILLO	ACCIAIO	5
19	VITE	SCREW	VIS	SCHRAUBE	TORNILLO	ACCIAIO	2
20	VITE	SCREW	VIS	SCHRAUBE	TORNILLO	OTTONE CW614N UNI EN 20898	1
21	SCATOLA ISPEZIONABILE	INSPECTION BOX	BOLTE D'INSPECTION	INSPEKTIONSSCHACHTEL	CAJA INSPECCIONABLE	HIPS	1
22	SCATOLA ISPEZIONABILE	INSPECTION BOX	BOLTE D'INSPECTION	INSPEKTIONSSCHACHTEL	CAJA INSPECCIONABLE	HIPS	1
23	CARTER	COVER	CARTER	ABDECKUNG	CHARTER	HIPS	1





Disponibile accessorio, art.9367, a pag. 267 - The accessory, item 9367, is available. See at page 267.



	MATERIALE MATERIALS	MISURA SIZE	DN	BOX	MASTER BOX	CODICE CODE	ØT	ØP	A	A1	B	C	D	ØE	h	H	I	Ch	L	L1	N	R	S	Kg			
	PLASTICA CROMATA	12	15	1	4	9370120000	12																	0,47			
		14	15			9370140000	14																			0,48	
	CROMED PLASTIC	16	15			9370160000	16	15	109	80	299	58	51	50	90	20	101	30	178	120	62,5	20	9			0,46	
		18	15			9370180000	18																				0,47
		22	15			9370220000	22																				0,53
	PLASTICA NERA	12	15	1	4	9370120001	12																	0,47			
		14	15			9370140001	14																			0,48	
	BLACK PLASTIC	16	15			9370160001	16	15	109	80	299	58	51	50	90	20	101	30	178	120	62,5	20	9			0,46	
		18	15			9370180001	18																				0,47
		22	15			9370220001	22																				0,53
	PLASTICA BIANCA	12	15	1	4	9370120002	12																	0,47			
		14	15			9370140002	14																			0,48	
	WHITE PLASTIC	16	15			9370160002	16	15	109	80	299	58	51	50	90	20	101	30	178	120	62,5	20	9			0,46	
		18	15			9370180002	18																				0,47
		22	15			9370220002	22																				0,53



Art. 935 C

-  Valvola a sfera con attacchi sede piana per scatola da incasso gas art. 9356.
-  Ball valve with flat seat connections for built-in gas box art. 9356.
-  Robinet à boisseau sphérique pour gaz, avec connexions à siège plan pour boîte à encastrer, article 9356.
-  Kugelhahn 1 Ausgangsanschluss, Flachdichtung, für Gas Einbauschachtel Art. 9356.
-  Válvula esfera para caja gas a embutir art. 9356.

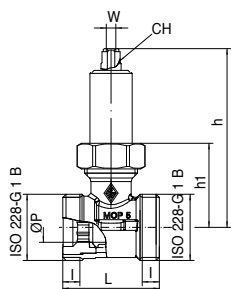





MISURA SIZE	DN	BOX	MASTER BOX	CODICE CODE	ØP	W	h	h1	L	I
1"	15	8	64	935C060000	15	3/16	91	42	48	8,5

Disponibile accessorio, art.9359, a pag. 266 - The accessory, item 9359, is available. See at page 266.



Art. 936 C

-  Valvola a sfera 3 uscite con attacchi sede piana per scatola da incasso gas art. 9357.
-  Ball valve with 3 outlets, flat seat connections, for built-in gas box art. 9357.
-  Robinet à boisseau sphérique pour gaz, 3 sorties, avec connexions à siège plan pour boîte à encastrer, article 9357.
-  Kugelhahn 3 Ausgangsanschlüsse, Flachdichtung, für Gas Einbauschachtel Art. 9357.
-  Válvula esfera con 3 salidas para caja gas a embutir art. 9357.

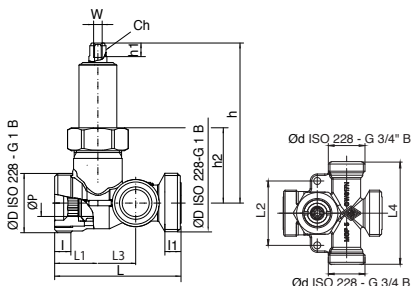



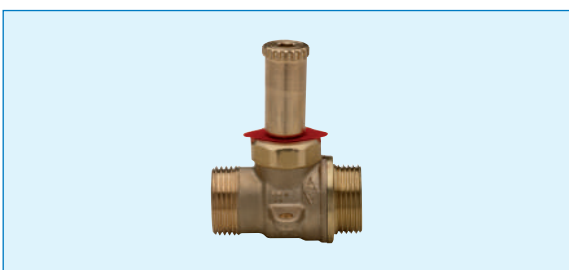

ØD x Ød	DN	BOX	MASTER BOX	CODICE CODE	ØP	W	h	h1	h2	L	L1	L2	L3	L4	I	I1	MOP	Kg
1" X 3/4"	15	5	40	936C580000	15	3/16	91	7	42	70	24	46	21	73	8,5	8	5	0,52

Disponibile accessorio, art.9359, a pag. 266 - The accessory, item 9359, is available. See at page 266.





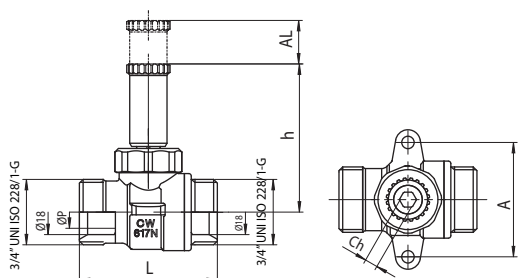

Art. 937 C

-  Valvola a sfera con attacchi eurocono gas per scatola da incasso gas art. 9362.
-  Gas full bore ball valve for built in inspection box art. 9362.
-  Robinet à boisseau sphérique passage total pour gaz pour boîte d'inspection à encastrer art. 9362.
-  Gas Kugelhahn mit vollem Durchgang für Inspektionsschachtel Art. 9362.
-  Válvula esfera por gas por caja inspeccionable a embutir art. 9362.



MISURA SIZE	DN	BOX	MASTER BOX	CODICE CODE	ØP	AL	A	Ch	L	h	MOP	Kg
3/4" x Ø18	15	8	64	937C040000	15	17	46	5	55,5	60	5	0,23



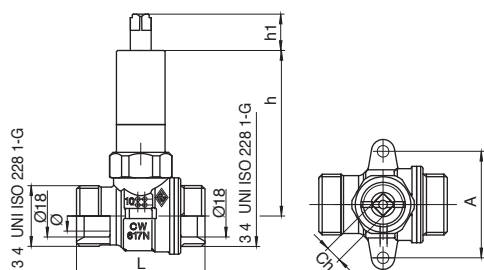
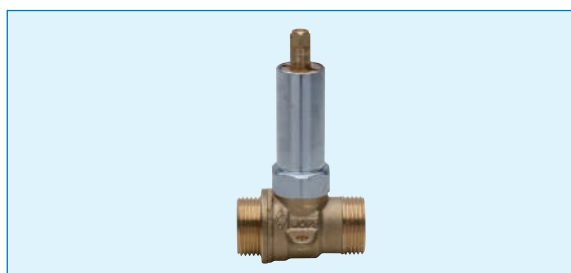

Art. 938 C

-  Valvola a sfera, con attacchi eurocono gas per scatola da incasso gas art. 9362.
-  Gas ball valve with euroconus seats for built-in box art. 9362.
-  Robinet à boisseau sphérique gaz avec sièges euroconiques pour boîte à encastrer art. 9362.
-  Gas Kugelhahn mit Eurokonus Sitz für Einbauschachtel Art. 9362.
-  Válvulas esfera gas con asientos eurocono por caja a empotrar art. 9362.

MISURA SIZE	DN	BOX	MASTER BOX	CODICE CODE	ØP	A	Ch	L	h	h1	MOP	Kg
3/4" x Ø18	15	8	64	938C040000	15	46	7	55,5	71,5	15,5	5	0,31





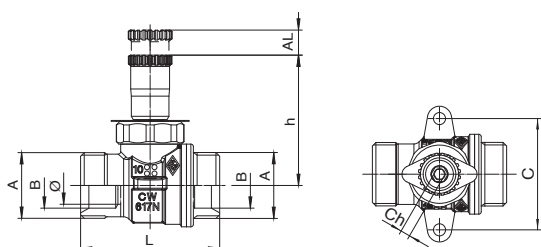
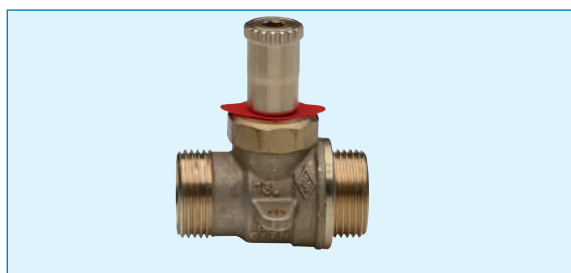

Art. 939 C

-  Valvola a sfera con attacchi eurocono gas per scatola da incasso gas art. 9362.
-  Gas full bore ball valve for built in inspection box art. 9362.
-  Robinet à boisseau sphérique passage total pour gaz pour boîte d'inspection à encastrer art. 9362.
-  Gas Kugelhahn mit vollem Durchgang für Inspektionsschachtel Art. 9362.
-  Válvula esfera por gas por caja inspeccionable a embutir art. 9362.

A x B	DN	BOX	MASTER BOX	CODICE CODE	ØP	AL	C	Ch	L	h	MOP	Kg
3/4" x Ø18	15	8	64	939C040000	15	10	46	4	55,5	52	5	0,27



Art. 940 C



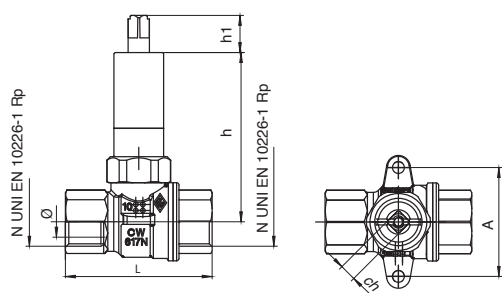

-  Valvola a sfera, con attacchi F/F gas per scatola da incasso gas art. 9362.
-  Gas ball valve with F/F connections for built-in box art. 9362.
-  Robinet à boisseau sphérique gaz connexions F/F pour boîte à encastrer art. 9362.
-  Gas Kugelhahn Innengewinde für Einbauschachtel Art. 9362.
-  Válvulas esfera gas con conexiones hembra/hembra por caja a empotrar art. 9362.

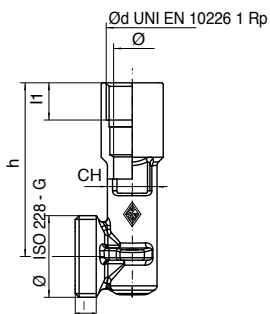
MISURA SIZE	DN	BOX	MASTER BOX	CODICE CODE	ØP	A	Ch	h1	L	h	MOP	Kg
1/2"	15	8	64	940C040000	15	46	7	15,5	62	71,5	5	0,32









Art. 9355

-  Raccordo di uscita per scatola da incasso gas artt. 9356/9363.
-  Outlet fitting for built-in gas box artt. 9356/9363.
-  Raccord de sortie gaz pour boîte à encastrer artt. 9356/9363.
-  Ausgangsschraubung für Gas Einbausachtel Artt. 9356/9363.
-  Conexión de salida por caja embutir gas artt. 9356/9363.

ØD x Ød	BOX	MASTER BOX	CODICE CODE	ØP	l	l1	Ch	ØA	L	h
1" X 1/2"	10	80	9355490000	15	8,5	15	20	25	23	70



Art. 9356



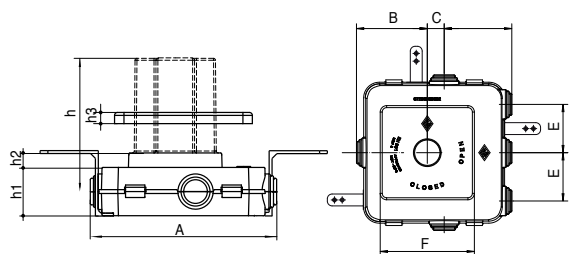

-  Scatola da incasso gas per artt. 9355/935C.
-  Gas built-in box for artt. 9355/935C.
-  Boîte à encastrer gaz pour artt. 9355/935C.
-  Gas Einbausachtel für Artt. 9355/935C.
-  Caja a embutir gas por artt. 9355/935C.



MISURA SIZE	BOX	MASTER BOX	CODICE CODE	A	B	C	D	E	F	h	h1	h2	h3
cm 11,7 X 11,7	1	2	9356000000	193	88	21	84	60	117	138	52	13	9,5



Art. 9357



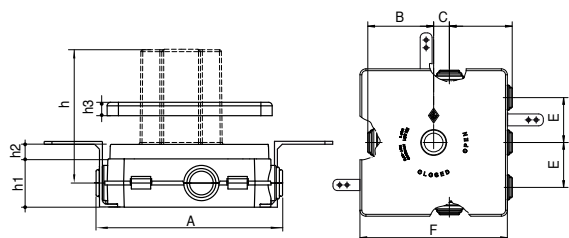

-  Scatola da incasso gas per valvola art. 936C.
-  Gas built-in box for valve art. 936C.
-  Boîte à encastrer gaz pour robinet art. 936C.
-  Gas Einbausachtel für Kugelhahn Art. 936C.
-  Caja a embutir gas por válvula art. 936C.

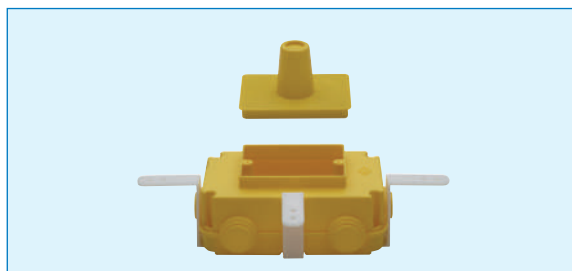

MISURA SIZE	BOX	MASTER BOX	CODICE CODE	A	B	C	D	E	F	h	h1	h2	h3
cm 19,7 X 19,7	1	2	9357000000	193	88	21	84	60	197	138	52	13	9,5

Art. 9362





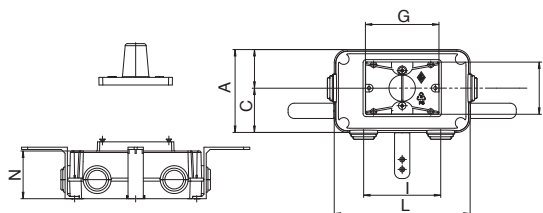



-  Scatola da incasso gas per valvole artt. 937C/938C/939C/940C.
-  Gas built-in box for valves artt. 937C/938C/939C/940C.
-  Boîte à encastrer gaz pour robinets artt. 937C/938C/939C/940C.
-  Gas Einbauschachtel für Kugelhähne Artt. 937C/938C/939C/940C.
-  Caja a embutir gas por válvulas artt. 937C/938C/939C/940C.

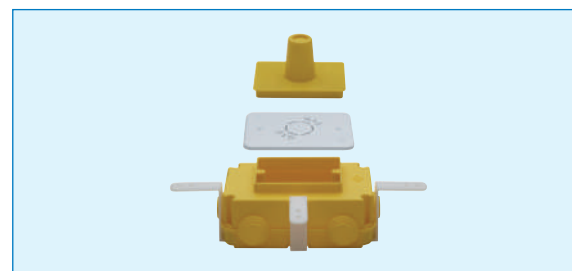

MISURA SIZE	BOX	MASTER BOX	CODICE CODE	A	C	D	G	I	L	M	N
cm 17,8X10,9	1	6	9362000000	109	58	51	96,5	101	178	62,5	68,5

Art. 9363



-  Scatola da incasso gas per raccordo art. 9355.
-  Gas built-in box for fitting art. 9355.
-  Boîte à encastrer gaz pour raccord art. 9355.
-  Gas Einbauschachtel für verschraubung Art. 9355.
-  Caja a embutir gas por conexión art. 9355.

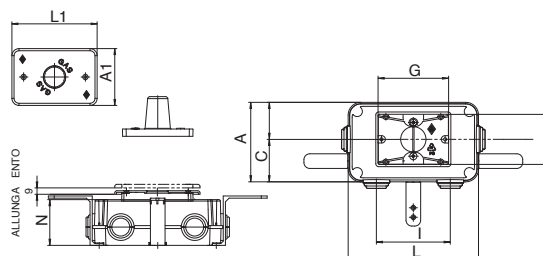





MISURA SIZE	BOX	MASTER BOX	CODICE CODE	A	A1	C	D	G	I	L	L1	N	M
cm 17,8X10,9	1	6	9363000000	109	80	58	51	96,5	101	178	120	62,5	68,5



Art. 9364

**BREVETTATO
PATENTED**



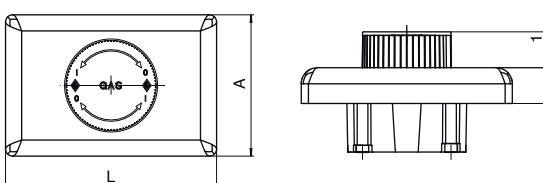

-  Organo di comando premi e gira a scomparsa per valvole art. 937C.
-  "push and turn" recessed control knob for valves art. 937C.
-  Commande de contrôle encastré "presse et tourne" pour robinets art. 937C.
-  Versenker Bedienknopf "pressen und drehen" für Kugelhähne Art. 937C.
-  Perilla de control empotrada "pulsar y girar" para válvulas art. 937C.

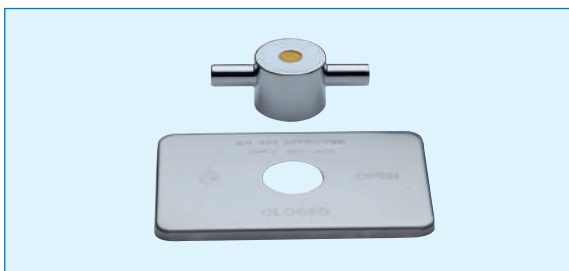

MISURA SIZE	BOX	MASTER BOX	CODICE CODE	A	L	P	P1	
cm 12 X 8	1	24	9364000000	80	PLASTICA CROMATA CROMED PLASTIC	120	20	20
cm 12 X 8	1	24	9364000001	80	PLASTICA NERA BLACK PLASTIC	120	20	20
cm 12 X 8	1	24	9364000002	80	PLASTICA BIANCA WHITE PLASTIC	120	20	20



Art. 9366



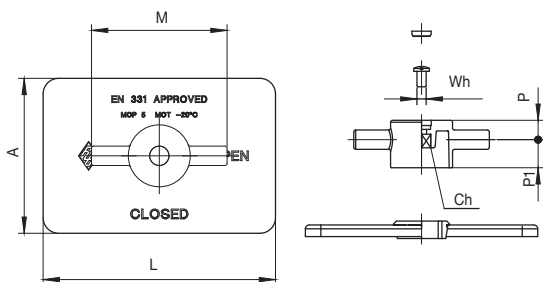

-  Kit farfalla per valvole artt. 938C/940C.
-  Spare T-handle for valves artt. 938C/940C.
-  Kit papillon pour robinets artt. 938C/940C.
-  Ersatz Flügelgriff für Kugelhähne Artt. 938C/940C.
-  Juego mariposa por válvulas artt. 938C/940C.



MISURA SIZE	SAC	BOX	MASTER BOX	CODICE CODE	A	L	Ch	Wh	P	P1	M	Kg
tutte - all	1	5	40	9366000000	80	120	7	W3/16	10,3	14,2	70	0,13



Art. 9358



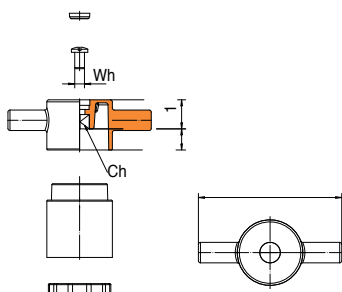

-  Kit farfalla per valvole artt. 935C/936C.
-  Spare T-handle for valves art. 935C/936C.
-  Kit papillon pour robinets artt. 935C/936C.
-  Ersatz Flügelgriff für Kugelhähne Artt. 935C/936C.
-  Juego mariposa por válvula artt. 935C/936C.



MISURE SIZE	BOX	MASTER BOX	CODICE CODE	Wh	Ch	M	P	P1
tutte - all	10	80	9358000000	W 3/16	7	70	10,3	14,2





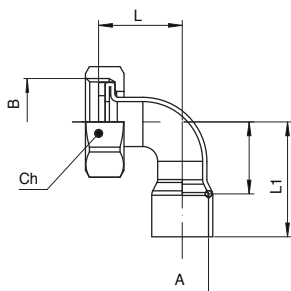

Art. 9360

-  Raccordo curvo con girello per gas.
-  Elbow with ring nut for gas.
-  Raccord coud avec ecrou pour gaz.
-  Winkel mit überwurfmutter für Gas.
-  Conexion curva con tuerca loca por gas.



A x B	BOX	MASTER BOX	CODICE CODE	L	L1	Z	Ch
14 X 3/4"	30	240	9360001405	25,5	32	19	30
16 X 3/4"	30	240	9360001605	25,5	35	22	30



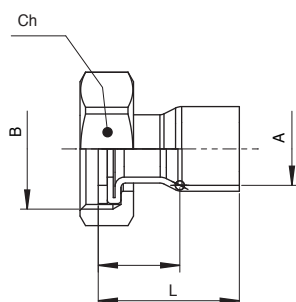

Art. 9361

-  Raccordo diritto con girello per gas.
-  Straight fitting with ring nut for gas.
-  Raccord droit avec ecrou pour gaz.
-  Anschluss mit Überwurfmutter für Gas.
-  Conexión recta con tuerca loca por gas.

A x B	BOX	MASTER BOX	CODICE CODE	L	Z	Ch
14 X 3/4"	40	320	9361001405	26	13,5	30
16 X 3/4"	40	320	9361001605	29	16,5	30
18 X 3/4"	30	240	9361001805	33	18,5	30
22 X 3/4"	30	240	9361002205	34	18	30
22 X 1"	20	160	9361002206	35	17,5	37
28 X 1"	20	160	9361002806	40	19,5	37





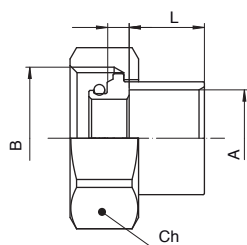

Art. 9365

-  Raccordo diritto in bronzo attacco eurocono per gas.
-  Straight bronze fitting with gas euroconus seat.
-  Raccord droit en bronze avec siège gaz euroconique.
-  Rotguss gerade Anschlussverschraubung mit Gas Eurokonus Sitz.
-  Racor recto en bronce con asiento gas eurocono.

A x B	BOX	MASTER BOX	CODICE CODE	L	Z	Ch
12 X 3/4"	50	400	9365120000	10	3,4	30
14 X 3/4"	50	400	9365140000	12	3,4	30
16 X 3/4"	50	400	9365160000	13	3,2	30
18 X 3/4"	50	400	9365180000	14	3,2	30
22 X 3/4"	20	160	9365220000	17	14,8	30



Art. 9368



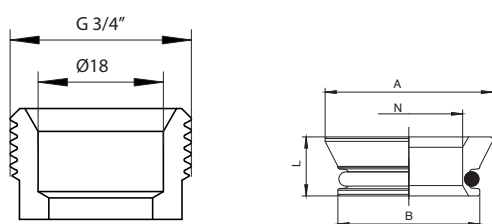

-  Adattatore che trasforma l'eurocono in sede piana.
-  Adapter to convert eurocone into flat seat connection.
-  Adapteur du siège euroconique/siège plat.
-  Adapter Eurokonus-Sitz/Flachsitz.
-  Adaptador eurocono/asiento plano.

A x B	BOX	MASTER BOX	CODICE CODE	DN	L
3/4" x 18	80	640	9368050000	15	7,4





Art. 53RI01



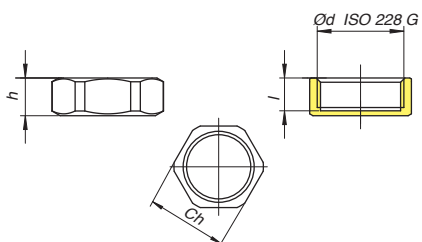

-  Tappo per collettore gas artt. 936C-9374.
-  Plug for gas manifold artt. 936C-9374
-  Bouchon pour collecteur gaz artt. 936C-9374.
-  Deckel für Gaskollektor Artt. 936C-9374.
-  Tapa para colector gas artt. 936C-9374.

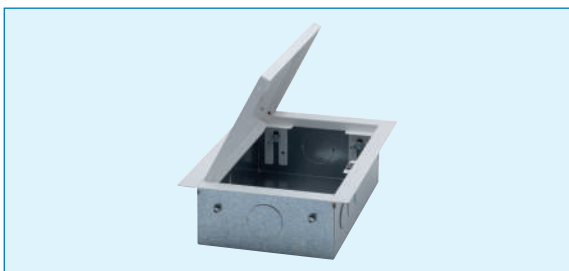

Ød	SAC.	CODICE CODE	h	l	ISO 228-G	Ch
3/4"	1	53RI0105	11,5	10	3/4	31
1"	1	53RI0106	13,5	10,5	1	38



Art. 9373



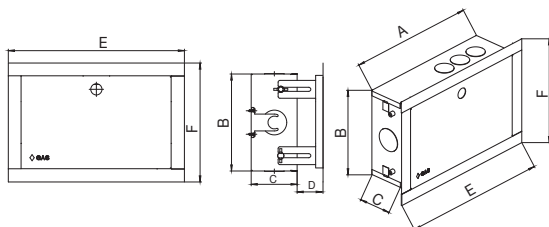

-  Cassetta da incasso per collettore gas.
-  Built-in box for gas manifold.
-  Boite d'inspection pour collecteur gaz.
-  Einbaukasten für Gasverteiler.
-  Caja a empotrar por colector de gas.

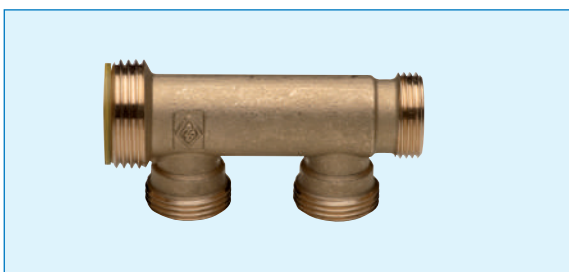

A x B x C	BOX	MASTER BOX	CODICE CODE	D	E	F
300 x 190 x 90	-	1	9373000000	50	345	233





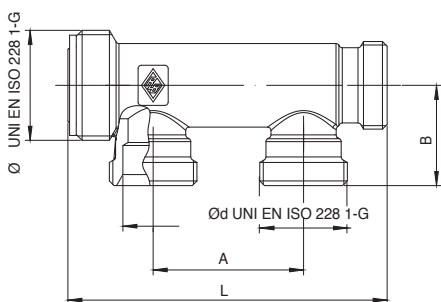

Art. 9374

-  Collettore gas con attacchi derivazione 3/4" eurocono.
-  Gas manifold with 3/4" euroconus connections.
-  Collecteur gaz avec raccords euroconiques 3/4".
-  Gasverteiler mit 3/4" Eurokonus Anschlüssen.
-  Colector de gas con conexiones eurocono 3/4".



ØD x Ød	N° vie	BOX	MASTER BOX	CODICE CODE	P	A	B	L
1" x 3/4"	2	4	32	9374005802	18	45	30	86,5
1" x 3/4"	3	4	32	9374005803	18	45	30	95,5



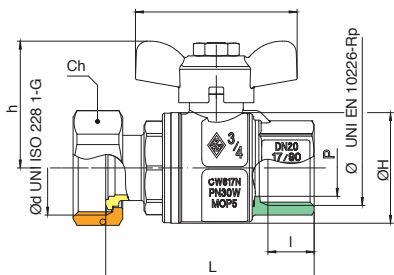

Art. 9375

-  Valvola a sfera per gas diritta per collegamento collettore gas art. 9374.
-  Straight ball valve for gas manifold connection art. 9374.
-  Robinet droit à boisseau sphérique pour connexion de collecteurs gaz art. 9374.
-  Kugelhahn für Gasverteileranschluss Art. 9374.
-  Valvula de esfera recta de conexion con colector de gas art. 9374.

ØD x Ød	BOX	MASTER BOX	CODICE CODE	ØH	M	I	h	L	Ch	MOP	Kg
3/4" x 1"	4	32	9375580000	39	57	16,3	44,7	73,5	37	5	0,38





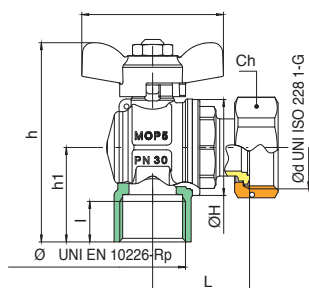

Art. 9376

-  Valvola a sfera per gas a squadra per collegamento collettore gas art. 9374.
-  Angle ball valve for gas manifold connection art. 9374.
-  Robinet équerre à boisseau sphérique pour connexion de collecteurs gaz art. 9374.
-  Eck-Kugelhahn für Gasverteileranschluss Art. 9374.
-  Valvula de esfera angular de conexion con colector de gas art. 9374.

ØD x Ød	BOX	MASTER BOX	CODICE CODE	I	L	h	h1	Ch	ØH	M	MOP	Kg
3/4" x 1"	4	32	9376580000	16,3	39	80,2	38	37	39	57	5	0,37



Art. 9377

-  Raccordo passamuro per gas, attacco multistrato per cassetta collettore gas art. 9373.
-  Wall duct fitting for gas manifold box with multilayer pipe fitting art. 9373.
-  Raccord parois pour boite collecteur gaz avec connexion tuyau multicouche art. 9373.
-  Wanddurchführung für Gasverteilerkasten mit Anschluss für Mehrschichtverbundrohr Art. 9373.
-  Racor de paredes por cajas colector gas con conexion tubo multicapa art. 9373.

A x B	BOX	MASTER BOX	CODICE CODE	Ød	ØE	ØF	L	Z
26 X 3/4"	4	32	9377260000	1"1/2	56	59	64	32,8
32 X 3/4"	4	32	9377320000	1"1/2	56	59	65,5	32,8

